



CAR OPS 2A

GENERAL AVIATION OPERATIONS (AEROPLANE)

FOREWORD

CONTENTS – PART I

CONTENTS – PART II

CONTENTS – PART III

REVISION RECORD

LIST of EFFECTIVE PAGES



This Page Intentionally Left Blank



FOREWORD

- (a) The Civil Aviation Authority of San Marino is known in these regulations as the “Authority”.
- (b) CAR OPS 2A addresses General Aviation regulations for aeroplanes. It includes Standards and Recommended Practices up to and including ICAO Annex 6, Part II, Amendment 40.
 - (1) Part I applies to all general aviation aeroplane operations, including those covered in Part II.
 - (2) Part II adds additional requirements for large and turbojet aeroplanes and applies to all international general aviation operations.
 - (3) [Part III adds additional requirements for large and turbojet aeroplanes used in fractional ownership programme operations.]

Note: Refer to applicability for each Part.

- (c) The regulation numbering system is different in each Part.
 - (1) CAR OPS 2A Part I numbering ends with 1-4 or 6-9.
 - (2) CAR OPS 2A Part II numbering ends with a 0 or 5.
 - (3) [CAR OPS 2A Part III numbering starts with 1000.]
- (d) The editing practices used in this document are as follows:
 - (1) ‘Shall’ is used to indicate a mandatory requirement.
 - (2) ‘Should’ is used to indicate a recommendation.
 - (3) ‘May’ is used to indicate discretion by the Authority, the industry or the applicant, as appropriate.
 - (4) ‘Will’ indicates a mandatory requirement.

Note: The use of the male gender implies the female gender and vice versa.

- (e) Paragraphs and sub-paragraphs with new, amended and corrected text will be enclosed within square brackets until a subsequent amendment is issued.
- (f) Unless otherwise stated, the definitions and abbreviations contained in CAR DEF are applicable to these regulations.



This Page Intentionally Left Blank



REVISION RECORD

REVISION NO.	EFFECTIVE DATE	ENTERED BY <i>(hardcopy only)</i>
Initial Issue	01 January 2020	
Rev 01	01 July 2020	
Rev 02	01 January 2021	
Rev 03	01 July 2021	
Rev 04	01 April 2022	
Rev 05	01 December 2022	
Rev 06	01 July 2023	
Rev 07	01 November 2023	



LIST OF EFFECTIVE PAGES

i 01 Nov 23
 ii 01 Nov 23
 iii 01 Nov 23
 iv 01 Nov 23
 v 01 Nov 23
 vi 01 Nov 23
 vii 01 Nov 23
 viii 01 Nov 23
 ix 01 Nov 23
 x 01 Nov 23
 xi 01 Nov 23
 xii 01 Nov 23
 xiii 01 Nov 23
 xiv 01 Nov 23

PART I

Subpart A

I-A-1 01 Jan 20
 I-A-2 01 Jan 20

Subpart B

I-B-1 01 Dec 22
 I-B-2 01 Dec 22
 I-B-3 01 Dec 22
 I-B-4 01 Dec 22

Subpart C

I-C-1 01 Dec 22
 I-C-2 01 Dec 22
 I-C-3 01 Dec 22
 I-C-4 01 Dec 22
 I-C-5 01 Dec 22
 I-C-6 01 Dec 22
 I-C-7 01 Dec 22
 I-C-8 01 Dec 22
 I-C-9 01 Dec 22
 I-C-10 01 Dec 22

Subpart D

I-D-1 01 Jan 20
 I-D-2 01 Jan 20

Subpart E

I-E-1 01 Nov 23
 I-E-2 01 Nov 23

I-E-3 01 Nov 23
 I-E-4 01 Nov 23
 I-E-5 01 Nov 23
 I-E-6 01 Nov 23
 I-E-7 01 Nov 23
 I-E-8 01 Nov 23
 I-E-9 01 Nov 23
 I-E-10 01 Nov 23
 I-E-11 01 Nov 23
 I-E-12 01 Nov 23
 I-E-13 01 Nov 23
 I-E-14 01 Nov 23

Subpart F

I-F-1 01 Jan 21
 I-F-2 01 Jan 21
 I-F-3 01 Jan 21
 I-F-4 01 Jan 21
 I-F-5 01 Jan 21
 I-F-6 01 Jan 21

Subpart G

I-G-1 01 Nov 23
 I-G-2 01 Nov 23

Subpart H

I-H-1 01 Jan 20
 I-H-2 01 Jan 20

Subpart I

I-I-1 01 Jan 20
 I-I-2 01 Jan 20

Subpart J

I-J-1 01 Jan 20
 I-J-2 01 Jan 20

PART II

Subpart A

II-A-1 01 Nov 23
 II-A-2 01 Nov 23
 II-A-3 01 Nov 23
 II-A-4 01 Nov 23

Subpart B

II-B-1 01 Jan 20
 II-B-2 01 Jan 20
 II-B-3 01 Jan 20
 II-B-4 01 Jan 20
 II-B-5 01 Jan 20
 II-B-6 01 Jan 20
 II-B-7 01 Jan 20
 II-B-8 01 Jan 20

Subpart C

II-C-1 01 Dec 22
 II-C-2 01 Dec 22
 II-C-3 01 Dec 22
 II-C-4 01 Dec 22
 II-C-5 01 Dec 22
 II-C-6 01 Dec 22
 II-C-7 01 Dec 22
 II-C-8 01 Dec 22

Subpart D

II-D-1 01 Dec 22
 II-D-2 01 Dec 22

Subpart E

II-E-1 01 Dec 22
 II-E-2 01 Dec 22
 II-E-3 01 Dec 22
 II-E-4 01 Dec 22
 II-E-5 01 Dec 22
 II-E-6 01 Dec 22
 II-E-7 01 Dec 22
 II-E-8 01 Dec 22
 II-E-9 01 Dec 22
 II-E-10 01 Dec 22
 II-E-11 01 Dec 22
 II-E-12 01 Dec 22
 II-E-13 01 Dec 22
 II-E-14 01 Dec 22
 II-E-15 01 Dec 22
 II-E-16 01 Dec 22
 II-E-17 01 Dec 22
 II-E-18 01 Dec 22
 II-E-19 01 Dec 22
 II-E-20 01 Dec 22
 II-E-21 01 Dec 22
 II-E-22 01 Dec 22



II-E-23 01 Dec 22
II-E-24 01 Dec 22
II-E-25 01 Dec 22
II-E-26 01 Dec 22

Subpart F

II-F-1 01 Jan 20
II-F-2 01 Jan 20

Subpart G

II-G-1 01 Jul 21
II-G-2 01 Jul 21

Subpart H

II-H-1 01 Nov 23
II-H-2 01 Nov 23

Subpart I

II-I-1 01 Jul 23
II-I-2 01 Jul 23

Subpart J

II-J-1 01 Jan 20
II-J-2 01 Jan 20

Subpart K

II-K-1 01 Jan 20
II-K-2 01 Jan 20

PART III

Subpart A

III-A-1 01 Nov 23
III-A-2 01 Nov 23
III-A-3 01 Nov 23
III-A-4 01 Nov 23

Subpart B

III-B-1 01 Nov 23
III-B-2 01 Nov 23
III-B-3 01 Nov 23
III-B-4 01 Nov 23
III-B-5 01 Nov 23
III-B-6 01 Nov 23
III-B-7 01 Nov 23

III-B-8 01 Nov 23

Subpart C

III-C-1 01 Nov 23
III-C-2 01 Nov 23
III-C-3 01 Nov 23
III-C-4 01 Nov 23

Subpart D

III-D-1 01 Nov 23
III-D-2 01 Nov 23

Subpart E

III-E-1 01 Nov 23
III-E-2 01 Nov 23
III-E-3 01 Nov 23
III-E-4 01 Nov 23

Subpart F

III-F-1 01 Nov 23
III-F-2 01 Nov 23
III-F-3 01 Nov 23
III-F-4 01 Nov 23

Subpart G

III-G-1 01 Nov 23
III-G-2 01 Nov 23
III-G-3 01 Nov 23
III-G-4 01 Nov 23
III-G-5 01 Nov 23
III-G-6 01 Nov 23

Subpart H

III-H-1 01 Nov 23
III-H-2 01 Nov 23

- End -



This Page Intentionally Left Blank



CONTENTS - PART I

ALL AEROPLANES

SUBPART A APPLICABILITY

OPS 2A.001	Applicability	I-A-1
OPS 2A.002	Exemptions	I-A-1

SUBPART B GENERAL

OPS 2A.101	Compliance with Laws, Regulations and Procedures	I-B-1
OPS 2A.102	Dangerous Goods	I-B-1
OPS 2A.103	Use of Psychoactive Substances.....	I-B-2
OPS 2A.104	Specific Approvals	I-B-2
OPS 2A.106	Protection of Safety Data and Safety Information	I-B-2
OPS 2A.107	Aeroplane Operated under an Article 83 <i>bis</i> Agreement	I-B-3

SUBPART C FLIGHT OPERATIONS PREPARATION

Operational Management (Before Flight)

OPS 2A.201	Operating Facilities	I-C-1
OPS 2A.202	Operation Instructions - General	I-C-1
OPS 2A.203	Aerodrome Operating Minima	I-C-1
OPS 2A.204	Passengers	I-C-3
OPS 2A.206	Pilot-in-Command Responsibilities	I-C-4
OPS 2A.207	Flight Planning	I-C-4
OPS 2A.208	Meteorological Conditions	I-C-4
OPS 2A.209	Destination Alternate Aerodromes.....	I-C-5
OPS 2A.211	Fuel and Oil Requirements – Non Turbojet Aeroplanes of 5700 kg or Below.....	I-C-6
OPS 2A.212	Refuelling with Passengers On Board.....	I-C-7
OPS 2A.213	Oxygen Supply	I-C-7

In-flight Procedures

OPS 2A.214	Aerodrome Considerations.....	I-C-7
OPS 2A.216	Weather Reporting by Pilots	I-C-7
OPS 2A.217	Hazardous Flight Conditions.....	I-C-7
OPS 2A.218	Flight Crew Members at Duty Stations.....	I-C-7
OPS 2A.219	Use of Oxygen.....	I-C-8
OPS 2A.221	In-flight Fuel Management.....	I-C-8
OPS 2A.222	Instrument Approach Procedures	I-C-9
OPS 2A.223	Duties of Pilot-in-Command	I-C-9
OPS 2A.224	Cabin Baggage (Take-off and Landing).....	I-C-10
OPS 2A.226	Flight Operations Officer/Flight Dispatcher	I-C-10

SUBPART D PERFORMANCE OPERATING LIMITATIONS

OPS 2A.301	General	I-D-1
------------	---------------	-------



SUBPART E INSTRUMENTS, EQUIPMENT AND FLIGHT DOCUMENTS

OPS 2A.401	General	I-E-1
OPS 2A.402	Instruments and Equipment - General	I-E-1
OPS 2A.403	Marking of Break-In Points.....	I-E-2
OPS 2A.404	Instruments and Equipment - Day VFR.....	I-E-2
OPS 2A.406	Instruments and Equipment - Night VFR.....	I-E-3
OPS 2A.407	Operating Lights for Night Operations	I-E-3
OPS 2A.408	Instruments and Equipment – IFR.....	I-E-4
OPS 2A.409	Flight Over Water.....	I-E-4
OPS 2A.411	Aeroplanes on Extended Over Water Flights	I-E-5
OPS 2A.412	Aeroplanes on Flights Over Designated Land Areas	I-E-6
OPS 2A.413	Supplemental Oxygen — Pressurised Aeroplane	I-E-6
OPS 2A.414	Supplemental Oxygen — Non-Pressurised Aeroplane	I-E-6
OPS 2A.416	Noise Certification	I-E-7
OPS 2A.417	Emergency Locator Transmitter (ELT)	I-E-7
OPS 2A.418	Pressure-Altitude Reporting Transponder.....	I-E-7
OPS 2A.419	Microphones.....	I-E-7
OPS 2A.421	Aeroplanes Equipped with ALS, HUD or Equivalent Displays, EVS, SVS and CVS....	I-E-7
OPS 2A.422	Ground proximity warning systems (GPWS)	I-E-7
OPS 2A.423	Electronic Flight Bags (EFB)	I-E-8
OPS 2A.424	Documents to be Carried.....	I-E-9
Appendix 1 to OPS 2A.407	Lights to be Displayed by Aeroplanes	I-E-10

SUBPART F COMMUNICATION, NAVIGATION & SURVEILLANCE EQUIPMENT

OPS 2A.501	Communication Equipment.....	I-F-1
OPS 2A.502	Navigation Equipment.....	I-F-2
OPS 2A.503	Performance Based Navigation	I-F-2
OPS 2A.504	NAT HLA.....	I-F-3
OPS 2A.506	RVSM.....	I-F-3
OPS 2A.507	Surveillance Equipment	I-F-4
Appendix 1 to OPS 2A.506	Height-keeping Performance Requirements	I-F-5

SUBPART G MAINTENANCE

OPS 2A.601	Owner’s Maintenance Responsibilities	I-G-1
OPS 2A.602	Continuing Airworthiness Records	I-G-1
OPS 2A.603	Modifications and Repairs.....	I-G-2
OPS 2A.604	Maintenance Release.....	I-G-2

SUBPART H FLIGHT CREW

OPS 2A.701	Composition of the Flight Crew	I-H-1
OPS 2A.702	Qualifications	I-H-1

SUBPART I MANUALS LOGS & RECORDS

OPS 2A.801	Flight Manual	I-I-1
------------	---------------------	-------

CAR OPS 2A



OPS 2A.802 Journey Log Book I-I-1
OPS 2A.803 Records of Emergency and Survival Equipment Carried I-I-1

SUBPART J SECURITY

OPS 2A.901 Security of Aeroplane..... I-J-1
OPS 2A.902 Reporting Acts of Unlawful Interference I-J-1



CONTENTS - PART II

LARGE AND TURBO JET AEROPLANES

SUBPART A APPLICABILITY

OPS 2A.005	Applicability	II-A-1
OPS 2A.010	Leasing and Interchange	II-A-1
OPS 2A.015	Fractional Ownership Operations	II-A-3

SUBPART B GENERAL

OPS 2A.110	Compliance with Laws, Regulations and Procedures	II-B-1
OPS 2A.120	Safety Management System	II-B-1

Appendix 1 to OPS 2A.120	Framework of a Safety Management System (SMS)	II-B-3
-----------------------------	---	--------

Appendix 2 to OPS 2A.120	Principles for Protection of Safety Data, Safety Information and Related Sources ..	II-B-7
-----------------------------	---	--------

SUBPART C FLIGHT OPERATIONS*Operational Management (Before Flight)*

OPS 2A.205	Operating Facilities	II-C-1
OPS 2A.210	Operator Notification	II-C-1
OPS 2A.215	Programme Operations Manual	II-C-1
OPS 2A.220	Operating Instructions - General	II-C-1
OPS 2A.225	In-flight Simulation of Emergency Situations	II-C-2
OPS 2A.230	Checklists	II-C-2
OPS 2A.235	Minimum Flight Altitudes	II-C-2
OPS 2A.240	Fatigue Management Programme	II-C-2
OPS 2A.245	Operational Flight Planning	II-C-2
OPS 2A.250	Take-off Alternate Aerodromes	II-C-2
OPS 2A.255	Fuel Requirements	II-C-3
OPS 2A.260	Refuelling with Passengers On Board	II-C-5
OPS 2A.265	Oxygen Supply	II-C-5

In-flight procedures

OPS 2A.270	Use of Oxygen	II-C-5
OPS 2A.275	Flight Recorder Operation	II-C-5
OPS 2A.280	Procedure for Rate of Climb or Descent	II-C-6
OPS 2A.285	Operating Procedures for Landing Performance	II-C-6
OPS 2A.290	Duties of Pilot-in-Command	II-C-6
OPS 2A.295	In-flight Fuel Management	II-C-6

Appendix 1 to OPS 2A.215	Content of a Programme Operations Manual	II-C-8
-----------------------------	--	--------



SUBPART D PERFORMANCE OPERATING LIMITATIONS

OPS 2A.310	Aeroplanes over 5700 kg	II-D-1
OPS 2A.320	Mass Limitations	II-D-1
OPS 2A.330	Take-off	II-D-2
OPS 2A.340	En-route — One Engine Inoperative	II-D-2
OPS 2A.350	Landing	II-D-2

SUBPART E INSTRUMENTS, EQUIPMENT AND FLIGHT DOCUMENTS

OPS 2A.405	General	II-E-1
OPS 2A.410	Aeroplanes on all Flights.....	II-E-1
OPS 2A.415	Manuals and Checklists	II-E-2
OPS 2A.420	Cockpit Voice Recorder	II-E-2
OPS 2A.425	Flight Data Recorder	II-E-2
OPS 2A.430	Data Link Recording	II-E-3
OPS 2A.435	Flight Data and Cockpit Voice Combination Recorder	II-E-4
OPS 2A.440	Long-range Over-water Flights	II-E-4
OPS 2A.445	Icing conditions	II-E-4
OPS 2A.450	Operations in Accordance with the Instrument Flight Rules	II-E-4
OPS 2A.455	Emergency Power for Electrically Operated Attitude Indicating Instruments.....	II-E-4
OPS 2A.460	Weather-detecting Equipment	II-E-5
OPS 2A.465	Operations above 15000 m (49000 ft) - Radiation Indicator	II-E-5
OPS 2A.470	Passenger and Cabin Crew Seats.....	II-E-5
OPS 2A.475	Airborne Collision Avoidance System (ACAS)	II-E-5
OPS 2A.480	Pressure-altitude Reporting Transponder	II-E-5
OPS 2A.485	Microphones	II-E-5
OPS 2A.490	Ground Proximity Warning Systems (GPWS).....	II-E-5

Appendix 1 to OPS 2A.420	Cockpit Voice Recorder (CVR) and Cockpit Audio Recording System (CARS)	II-E-7
-----------------------------	---	--------

Appendix 1 to OPS 2A.420 to 2.430 inclusive	Flight Recorders – General.....	II-E-8
---	---------------------------------	--------

Appendix 2 to OPS 2A.420 to 2.430 inclusive	Inspection of Flight Recorder Systems	II-E-10
---	---	---------

Appendix 1 to OPS 2A.425	Flight Data Recorder (FDR) and Aircraft Data Recording Systems (ADRS)	II-E-12
-----------------------------	---	---------

Appendix 2 to OPS 2A.425	Airborne Image Recorder (AIR) and Airborne Image Recording System (AIRS). ..	II-E-14
-----------------------------	--	---------

Appendix 1 to OPS 2A.430	Data Link Recorder (DLR) – Applications to be Recorded.....	II-E-15
-----------------------------	---	---------

Appendix 1 to OPS 2A.425	Parameter Characteristics for Flight Data Recorders	II-E-16
-----------------------------	---	---------



Appendix 2 to
 OPS 2A.425 Parameter Characteristics for Aircraft Data Recording Systems (ADRS)..... II-E-23

SUBPART F COMMUNICATION, NAVIGATION & SURVEILLANCE EQUIPMENT

OPS 2A.510 Communication Equipment..... II-F-1
 OPS 2A.520 Installation II-F-1
 OPS 2A.530 Electronic Navigation Data Management II-F-1

SUBPART G MAINTENANCE

OPS 2A.610 Operator’s Maintenance Responsibilities.....II-G-1
 OPS 2A.630 Maintenance Programme.....II-G-1
 OPS 2A.640 Continuing Airworthiness InformationII-G-1
 OPS 2A.650 Maintenance ReleaseII-G-1

SUBPART H FLIGHT CREW

OPS 2A.710 Composition of the Flight CrewII-H-1
 OPS 2A.720 Flight Crew Member Emergency Duties.....II-H-1
 OPS 2A.730 Flight Crew Member Training ProgrammesII-H-1
 OPS 2A.740 QualificationsII-H-1

SUBPART I MANUALS, LOGS AND RECORDS

OPS 2A.820 Maintenance Programme..... II-I-1
 OPS 2A.830 Technical Log..... II-I-2

SUBPART J SECURITY

OPS 2A.910 Security ProgrammeII-J-1
 OPS 2A.920 Flight Crew Compartment Security II-J-1

SUBPART K CABIN CREW

OPS 2A.950 Assignment of Emergency DutiesII-K-1
 OPS 2A.960 Cabin Crew at Emergency Evacuation Stations.....II-K-1
 OPS 2A.970 Protection of Cabin Crew During FlightII-K-1
 OPS 2A.980 TrainingII-K-1



CONTENTS - PART III

FRACTIONAL OWNERSHIP PROGRAMME

SUBPART A GENERAL

OPS 2A.1005	Applicability	III-A-1
OPS 2A.1010	Accountable Manager.....	III-A-1
OPS 2A.1015	Management contract between fractional owner and programme operator	III-A-1
OPS 2A.1020	Prohibitions and limitations	III-A-1
OPS 2A.1025	Flight conducted under CAR OPS 1	III-A-2
OPS 2A.1030	Operational control responsibilities and delegation	III-A-2
OPS 2A.1035	Issuing or denying management specifications.....	III-A-2
OPS 2A.1040	Safety Management System	III-A-3
OPS 2A.1045	Definitions	III-A-3

SUBPART B CERTIFICATION

OPS 2A.1105	General rules for certification.....	III-B-1
OPS 2A.1110	Issue, variation and continued validity of management specifications	III-B-2
OPS 2A.1115	Administrative requirements	III-B-2
OPS 2A.1120	The management and organisation	III-B-3
OPS 2A.1125	Management specifications	III-B-5
OPS 2A.1130	Amendment to management specifications.....	III-B-6
OPS 2A.1135	Conducting tests and inspections	III-B-8
OPS 2A.1140	Internal safety reporting and incident/accident response	III-B-8

SUBPART C FLIGHT OPERATIONS

OPS 2A.1205	Flight scheduling and locating requirements.....	III-C-1
OPS 2A.1210	Pilot in command or second in command	III-C-1
OPS 2A.1215	Operating information required.....	III-C-1
OPS 2A.1220	Passenger awareness.....	III-C-2
OPS 2A.1225	IFR take-off, approach and landing minimums.....	III-C-3

SUBPART D PERFORMANCE OPERATING LIMITATIONS

OPS 2A.1305	Aeroplane limitations at destination and alternate airports	III-D-1
-------------	---	---------

SUBPART E MAINTENANCE AND CONTINUING AIRWORTHINESS

OPS 2A.1405	Operator's continuing airworthiness responsibilities	III-E-1
OPS 2A.1410	General continuing airworthiness arrangements	III-E-1
OPS 2A.1415	Operator's aeroplane maintenance programme	III-E-2

SUBPART F FLIGHT CREW

OPS 2A.1505	Flight crew.....	III-F-1
OPS 2A.1510	Flight, duty and rest time requirements	III-F-2
OPS 2A.1515	Training – General.....	III-F-2
OPS 2A.1520	Training programme.....	III-F-3
OPS 2A.1525	Crew member emergency and safety equipment training.....	III-F-3



SUBPART G MANUALS AND RECORDS

OPS 2A.1605	Programme operations manual requirements	III-G-1
OPS 2A.1610	Programme operations manual contents.....	III-G-2
OPS 2A.1615	Recordkeeping.....	III-G-3

SUBPART H CABIN CREW

OPS 2A.1705	General	III-H-1
OPS 2A.1710	Training and checking	III-H-2
OPS 2A.1715	Training records	III-H-2



PART I

ALL AEROPLANES



This Page Intentionally Left Blank

**SUBPART A****APPLICABILITY****OPS 2A.001 Applicability**

CAR OPS 2A, Part I applies to all General Aviation aeroplane operations.

Note: CAR OPS 2A, Part II adds additional requirements for large and turbojet aeroplanes.

OPS 2A.002 Exemptions

The Authority may exceptionally grant an exemption from the provisions of CAR OPS 2A when satisfied that there is a need and subject to compliance with any supplementary condition the Authority considers necessary in order to ensure an acceptable level of safety in the particular case.



This Page Intentionally Left Blank

**SUBPART B****GENERAL****OPS 2A.101 Compliance with laws, regulations and procedures**

- (a) The pilot-in-command shall comply with the laws, regulations and procedures of those States in which operations are conducted.
- (b) The pilot-in-command shall be familiar with the laws, regulations and procedures, pertinent to the performance of his or her duties, prescribed for the areas to be traversed, the aerodromes to be used and the air navigation facilities relating thereto. The pilot-in-command shall ensure that other members of the flight crew are familiar with such of these laws, regulations and procedures as are pertinent to the performance of their respective duties in the operation of the aeroplane.
- (c) The pilot-in-command shall have responsibility for operational control.
- (d) If an emergency situation which endangers the safety or security of the aeroplane or persons necessitates the taking of action which involves a violation of local regulations or procedures, the pilot-in-command shall notify the appropriate local authority without delay. If required by the State in which the incident occurs, the pilot-in-command shall submit a report on any such violation to the appropriate authority of such State; in that event, the pilot-in-command shall also submit a copy of it to the Authority, as the State of Registry of the aeroplane. Such reports shall be submitted as soon as possible and normally within ten days.
- (e) The pilot-in-command shall ensure that flight crew members demonstrate the ability to speak and understand the English language.

OPS 2A.102 Dangerous goods

- (a) The transport of dangerous goods by air shall be conducted in accordance with CAR DG as last amended and amplified by the Technical Instructions for the Safe Transport of Dangerous Goods by Air (ICAO Doc 9284-AN/905), including its supplements and any other addenda or corrigenda.
- (b) Dangerous goods shall only be transported by the operator approved by the Authority except when;
 - (1) they are not subject to the Technical Instructions in accordance with Part 1 of those Instructions; or
 - (2) they are carried by passengers or the pilot-in-command, or are in baggage, in accordance with Part 8 of the Technical Instructions.
- (c) The pilot-in-command shall take all reasonable measures to prevent dangerous goods from being carried on board inadvertently.
- (d) The pilot-in-command shall, in accordance with the Technical Instructions, report without delay to the Authority and the appropriate authority of the State of occurrence in the event of any dangerous goods accidents or incidents.
- (e) The pilot-in-command shall ensure that passengers are provided with information about dangerous goods in accordance with the Technical Instructions.

**OPS 2A.103 Use of psychoactive substances**

Note: Refer to CAR OPS 0

OPS 2A.104 Specific Approvals

- (a) The operator shall not operate an aeroplane for the purpose of General Aviation operations otherwise than under, and in accordance with, the approvals and limitations of a Specific Approval issued for that aeroplane.
- (b) The pilot-in-command shall not conduct operations for which a specific approval is required unless such approval has been issued by the Authority.
- (c) Specific approvals shall follow the layout listed in ICAO Annex 6 Part II and contain the information on the following required approvals;
 - (1) Low Visibility Operations;
 - (2) Operational credit operations for advanced aircraft, when used for low visibility operations;
 - (3) Performance Based Operations (PBN);
 - (4) Carriage of Dangerous Goods;
 - (5) RVSM;
 - (6) NAT HLA;
 - (7) Use of EFB (installed or portable);
 - (8) Use of CPDLC;
 - (9) Use of ADS-B Out;
 - (10) Use of ADS C;
 - (11) Step Approaches;
 - (12) Required Communications Performance (RCP); and
 - (13) Required Surveillance Performance (RSP).

OPS 2A.106 Protection of Safety Data and Safety Information

- (a) The Authority shall not allow the use of recordings or transcripts of CVR, CARS, Class A AIR and Class A AIRS for purposes other than the investigation of an accident or incident as per ICAO Annex 13, except where the recordings or transcripts are;
 - (1) related to a safety-related event identified in the context of a safety management system; are restricted to the relevant portions of a de-identified transcript of the recording; and are subject to the protections accorded by Appendix 2 to OPS 2A.120;



- (2) sought for use in criminal proceedings not related to an event involving an accident or incident investigation and are subject to the protections accorded by Appendix 2 to OPS 2A.120; or
 - (3) used for inspections of flight recorder systems.
- (b) The Authority shall not allow the use of recordings or transcripts of FDR, ADRS, Class B and C AIR, and Class B and C AIRS for purposes other than the investigation of an accident or incident as per ICAO Annex 13, except where the recordings or transcripts are subject to the protections accorded by Appendix 2 to OPS 2A.120 and are:
- (1) used by the operator for airworthiness or maintenance purposes;
 - (2) sought for use in proceedings not related to an event involving an accident or incident investigation;
 - (3) de-identified; or
 - (4) disclosed under secure procedures.

Note 1: When an investigation under Annex 13 is instituted, investigation records are subject to the protections accorded by Annex 13.

Note 2: Provisions on the protection of safety data, safety information and related sources are contained in Appendix 2 to OPS 2A.120.

OPS 2A.107 Aeroplane operated under an Article 83 *bis* agreement

- (a) An aeroplane, when operating under an Article 83 *bis* agreement entered into between the State of Registry and the State of the principal location of a general aviation operator, shall carry a certified true copy of the agreement summary, in either an electronic or hard copy format. When the summary is issued in a language other than English, an English translation shall be included.
- (b) The agreement summary of an Article 83 *bis* agreement shall be accessible to a civil aviation safety inspector to determine which functions and duties are transferred under the agreement by the State of Registry to the State of the principal location of a general aviation operator, when conducting surveillance activities such as ramp checks.
- (c) The agreement summary shall be transmitted to ICAO together with the Article 83 *bis* Agreement for registration with the ICAO Council by the State of Registry or the State of the principal location of a general aviation operator.

Note: The agreement summary transmitted with the Article 83 bis agreement registered with the ICAO Council contains the list of all aircraft affected by the agreement. However, the certified true copy to be carried on board will need to list only the specific aircraft carrying the copy.

- (d) The agreement summary should contain the information in ICAO 6, Part II, Appendix 2.5 for the specific aircraft and should follow the layout of Appendix 2.5, paragraph 2.



This Page Intentionally Left Blank



SUBPART C

FLIGHT OPERATIONS

Operational Management (Before Flight)

OPS 2A.201 Operating Facilities

The pilot-in-command shall not commence a flight unless it has been ascertained by every reasonable means available that the ground and/or water facilities including communication facilities and navigation aids available and directly required on such flight, for the safe operation of the aeroplane, are adequate for the type of operation under which the flight is to be conducted.

The pilot-in-command, in making a decision on the adequacy of facilities and services available at an aerodrome of intended operation, should assess the level of safety risk associated with the aircraft type and nature of the operation, in relation to the availability of rescue and fire-fighting services (RFFS).

OPS 2A.202 Taxying of Aeroplanes

An aeroplane shall not be taxied on the movement area of an aerodrome unless the person at the controls is an appropriately qualified pilot or;

- (a) has been duly authorised by the owner or in the case where it is leased the lessee, or a designated agent;
- (b) is fully competent to taxi the aeroplane;
- (c) is qualified to use the radio if radio communications are required; and
- (d) has received instruction from a competent person in respect of aerodrome layout, and where appropriate, information on routes, signs, marking, lights, ATC signals and instructions, phraseology and procedures, and is able to conform to the operational standards required for safe movement at the aerodrome.

OPS 2A.203 Aerodrome Operating Minima

- (a) The pilot-in-command shall establish aerodrome operating minima in accordance with criteria specified by the Authority, as State of Registry, for each aerodrome to be used in operations. When establishing aerodrome operating minima, any conditions that may be prescribed in the list of specific approvals shall be observed. Such minima shall not be lower than any that may be established for such aerodromes by the State of the Aerodrome, except when specifically approved by that State.
- (b) The Authority, as the State of Registry, shall authorise operational credit(s) for operations with advanced aircraft. Where the operational credit relates to low visibility operations, the Authority, as the State of Registry, shall issue a specific approval. Such authorisations shall not affect the classification of the instrument approach procedure.

Note: Operational credit includes:

- (1) *for the purposes of an approach ban under OPS 2A.214 or dispatch considerations, a minimum below the aerodrome operating minima;*



- (2) *reducing or satisfying the visibility requirements; or*
 - (3) *requiring fewer ground facilities as compensated for by airborne capabilities.*
- (c) When issuing a specific approval for the operational credit, the Authority, as the State of Registry shall ensure that;
- (1) the aeroplane meets the appropriate airworthiness certification requirements;
 - (2) the information necessary to support effective crew tasks for the operation is appropriately available to both pilots where the number of flight crew members specified in the programme operations manual is more than one;
 - (3) the operator/owner has carried out a safety risk assessment of the operations supported by the equipment;
 - (4) the operator/owner has established and documented normal and abnormal procedures and MEL;
 - (5) the operator/owner has established a training programme for the flight crew members and relevant personnel involved in the flight preparation;
 - (6) the operator/owner has established a system for data collection, evaluation and trend monitoring for low visibility operations for which there is an operational credit; and
 - (7) the operator has instituted appropriate procedures in respect of continuing airworthiness (maintenance and repair) practices and programmes.
- (d) For operations with operational credit with minima above those related to low visibility operations, the Authority, as the State of the Operator shall establish criteria for the safe operation of the aeroplane.
- (e) Instrument approach operations shall be classified based on the designed lowest operating minima below which an approach operation shall only be continued with the required visual reference as follows:
- (1) Type A: a minimum descent height or decision height at or above 75 m (250 ft); and
 - (2) Type B: a decision height below 75 m (250 ft). Type B instrument approach operations are categorized as:
 - (i) Category I (CAT I): a decision height not lower than 60 m (200 ft) and with either a visibility not less than 800 m or a runway visual range not less than 550 m;
 - (ii) Category II (CAT II): a decision height lower than 60 m (200 ft), but not lower than 30 m (100 ft) and a runway visual range not less than 300 m;
 - (iii) Category III: a decision height lower than 100 ft (30 m) or no decision height and a runway visual range less than 300 m or no runway visual range limitation. These are:
 - (A) Category IIIA (CAT IIIA): a decision height lower than 30 m (100 ft) or no decision height and a runway visual range not less than 175 m;



- (B) Category IIIB (CAT IIIB): a decision height lower than 15 m (50 ft), or no decision height and a runway visual range less than 175 m but not less than 50 m; and
- (C) Category IIIC (CAT IIIC): no decision height and no runway visual range limitations.

Note 1: Where decision height (DH) and runway visual range (RVR) fall into different categories of operation, the instrument approach operation would be conducted in accordance with the requirements of the most demanding category (e.g. an operation with a DH in the range of CAT IIIA but with an RVR in the range of CAT IIIB would be considered a CAT IIIB operation or an operation with a DH in the range of CAT II but with an RVR in the range of CAT I would be considered a CAT II operation). This does not apply if the RVR and/or DH has been approved as operational credit.

Note 2: The required visual reference means that section of the visual aids or of the approach area which should have been in view for sufficient time for the pilot to have made an assessment of the aeroplane position and rate of change of position, in relation to the desired flight path. In the case of a circling approach operation the required visual reference is the runway environment.

- (d) The operating minima for 2D instrument approach operations using instrument approach procedures shall be determined by establishing a minimum descent altitude (MDA) or minimum descent height (MDH), minimum visibility and, if necessary, cloud conditions.
- (e) The operating minima for 3D instrument approach operations using instrument approach procedures shall be determined by establishing a decision altitude (DA) or decision height (DH) and the minimum visibility or RVR.
- (f) The Authority shall issue a specific approval for instrument approach operations in low visibility which shall only be conducted when RVR information is provided.
- (g) For take-off in low visibility, the Authority shall issue a specific approval for the minimum take-off RVR.

OPS 2A.204 Passengers

- (a) The operator, and pilot-in-command, shall ensure that passengers are made familiar with the location and use of:
 - (1) seat belts;
 - (2) emergency exits;
 - (3) life jackets, if the carriage of life jackets is prescribed;
 - (4) oxygen dispensing equipment if the use of oxygen is anticipated; and
 - (5) other emergency equipment provided for individual use, including passenger emergency briefing cards.



- (b) The pilot-in-command shall ensure that all persons on board are aware of the location and general manner of use of the principal emergency equipment carried for collective use.
- (c) In an emergency during flight, the pilot-in-command shall ensure that passengers are instructed in such emergency action as may be appropriate to the circumstances.
- (d) The pilot-in-command shall ensure that, during take-off and landing and whenever considered necessary by reason of turbulence or any emergency occurring during flight, all passengers on board shall be secured in their seats by means of the seat belts or harnesses provided.

OPS 2A.206 Pilot-in-Command Responsibilities

- (a) The pilot-in-command shall be responsible for the operation, safety and security of the aeroplane and the safety of all crew members, passengers and cargo on board
- (b) A flight shall not be commenced until the pilot-in-command is satisfied that:
 - (1) the aeroplane is airworthy, duly registered and that appropriate certificates with respect thereto are aboard the aeroplane;
 - (2) the instruments and equipment installed in the aeroplane are appropriate, taking into account the expected flight conditions;
 - (3) any necessary maintenance has been performed in accordance with Subpart G of this Part;
 - (4) the mass of the aeroplane and centre of gravity location are such that the flight can be conducted safely, taking into account the flight conditions expected;
 - (5) any load carried is properly distributed and safely secured; and
 - (6) the aeroplane operating limitations, contained in the flight manual, or its equivalent, will not be exceeded.

Note: The pilot-in-command should have sufficient information on climb performance with all engines operating to enable determination of the climb gradient that can be achieved during the departure phase for the existing take-off conditions and intended take-off technique.

OPS 2A.207 Flight planning

Before commencing a flight the pilot-in-command shall be familiar with all available meteorological information appropriate to the intended flight. Preparation for a flight away from the vicinity of the place of departure, and for every flight under the instrument flight rules, shall include:

- (a) a study of available current weather reports and forecasts; and
- (b) the planning of an alternative course of action to provide for the eventuality that the flight cannot be completed as planned, because of weather conditions.

OPS 2A.208 Meteorological Conditions

- (a) The Authority has established criteria to be used for the estimated time of use of an aerodrome, including a margin of time; as follows;



- (1) A flight to be conducted in accordance with VFR shall not be commenced unless current meteorological reports or a combination of current reports and forecasts indicate that the meteorological conditions along the route or that part of the route to be flown under the VFR will, at the appropriate time, be such as to enable compliance with these rules.
- (2) A flight to be conducted in accordance with the instrument flight rules shall not:
 - (i) take off from the departure aerodrome unless the meteorological conditions, one hour before and ending one hour after the estimated time of arrival at the aerodrome, are at or above the aerodrome operating minima for that operation; and
 - (ii) take off or continue beyond the point of in-flight re-planning unless at the aerodrome of intended landing or at each alternate aerodrome to be selected, current meteorological reports or a combination of current reports and forecasts indicate that the meteorological conditions will be, one hour before and ending one hour after the estimated time of arrival at the aerodrome, at or above the aerodrome operating minima for that operation.
- (b) A flight to be operated in known or expected icing conditions shall not be commenced unless the aeroplane is certificated and equipped to cope with such conditions.
- (c) A flight to be planned or expected to operate in suspected or known ground icing conditions shall not take off unless the aeroplane has been inspected for icing and, if necessary, has been given appropriate de-icing/anti-icing treatment. Accumulation of ice or other naturally occurring contaminants shall be removed so that the aeroplane is kept in an airworthy condition prior to take-off.

OPS 2A.209 Destination Alternate Aerodromes

For a flight to be conducted in accordance with the instrument flight rules, at least one destination alternate aerodrome shall be selected and specified in the flight plans, unless:

- (a) the duration of the flight from the departure aerodrome, or from the point of in-flight re-planning, to the destination aerodrome is such that, taking into account all meteorological conditions and operational information relevant to the flight, at the estimated time of use, a reasonable certainty exists that:
 - (1) the approach and landing may be made under visual meteorological conditions; and
 - (2) separate runways are usable at the estimated time of use of the destination aerodrome with at least one runway having an operational instrument approach procedure; or
- (b) the aerodrome of intended landing is isolated; and
 - (1) a standard instrument approach procedure is prescribed for the aerodrome of intended landing;
 - (2) a point of no return has been determined; and
 - (3) a flight shall not be continued past the point of no return unless available current meteorological information indicates that the following meteorological conditions will exist at the estimated time of use:



- (i) a cloud base of at least 300 m (1000 ft) above the minimum associated with the instrument approach procedure; and
- (ii) visibility of at least 5.5 km (3NM) or of 4 km (2NM) more than the minimum associated with the instrument approach procedure.

Note: Separate runways are two or more runways at the same aerodrome configured such that if one runway is closed, operations to the other runway(s) can be conducted.

OPS 2A.211 Fuel and Oil requirements – Non turbojet Aeroplanes of 5700 kg or below

A flight shall not be commenced unless, taking into account both the meteorological conditions and any delays that are expected in flight, the aeroplane carries sufficient fuel and oil to ensure that it can safely complete the flight. The amount of fuel to be carried must permit:

- (a) for visual flight rules (VFR) flights:
 - (1) by day, to fly to the aerodrome of intended landing, and after that, have a final reserve fuel for at least 30 minutes at normal cruising altitude; or
 - (2) by night, to fly to the aerodrome of intended landing and thereafter have a final reserve fuel for at least 45 minutes at normal cruising altitude;
- (b) for IFR flights:
 - (1) when no destination alternate is required or when the flight is to an isolated aerodrome, to fly to the aerodrome of intended landing, and after that, have a final reserve fuel for at least 45 minutes at normal cruising altitude; or
 - (2) when a destination alternate is required, to fly to the aerodrome of intended landing, then to an alternate aerodrome and after that, have a final reserve fuel for at least 45 minutes at normal cruising altitude.

(c) Contingencies

In computing the fuel required including to provide for contingency, the following shall be taken into consideration:

- (1) forecast meteorological conditions;
- (2) anticipated ATC routings and traffic delays;
- (3) procedures for loss of pressurisation or failure of one engine while en-route, where applicable; and
- (4) any other condition that may delay the landing of the aeroplane or increase fuel and/or oil consumption.

Note: Nothing shall preclude amendment of a flight plan in-flight, in order to re-plan the flight to another destination, provided that all requirements can be complied with from the point where the flight is re-planned.



OPS 2A.212 Refuelling with Passengers on Board

An aeroplane shall not be refuelled when passengers are embarking, on board or disembarking unless it is properly attended by qualified personnel ready to initiate and direct an evacuation of the aeroplane by the most practical and expeditious means available.

OPS 2A.213 Oxygen Supply

The pilot-in-command shall ensure that breathing oxygen is available to crew members and passengers in sufficient quantities for all flights at such altitudes where a lack of oxygen might result in impairment of the faculties of crew members or harmfully affect passengers.

In-flight Procedures

OPS 2A.214 Aerodrome Considerations

- (a) A flight shall not be continued towards the aerodrome of intended landing, unless the latest available information indicates that at the expected time of arrival, a landing can be effected at that aerodrome or at least one destination alternate aerodrome, in compliance with the operating minima established.
- (b) An instrument approach shall not be continued below 300 m (1000 ft) above the aerodrome elevation or into the final approach segment unless the reported visibility or controlling RVR is above the aerodrome operating minimum.
- (c) If, after entering the final approach segment, or after descending below 300 m (1000 ft) above the aerodrome elevation, the reported visibility or the touchdown RVR falls below the specified minimum, the approach may be continued to DA/H or MDA/H. In any case, an aeroplane shall not continue its approach-to-land beyond a point at which the limits of the aerodrome operating minima would be infringed.
- (d) An approach to land should not be continued below 300 m (1000 ft) above aerodrome elevation unless the commander is satisfied that, with the runway surface condition information available, the aeroplane performance information indicates that a safe landing can be made.

OPS 2A.216 Weather Reporting by Pilots

When weather conditions likely to affect the safety of other aeroplanes are encountered, they should be reported as soon as possible.

OPS 2A.217 Hazardous Flight Conditions

- (a) Hazardous flight conditions encountered, other than meteorological conditions, should be reported to the appropriate aeronautical station as soon as possible. The reports so rendered should give such details as may be pertinent to the safety of other aeroplanes.
- (b) The commander should report the runway braking action by special air-report (AIREP) when the runway braking action encountered is not as good as reported.

OPS 2A.218 Flight Crew Members at Duty Stations

- (a) Take-off and landing.



All flight crew members required to be on flight deck duty shall be at their stations.

- (b) En-route.

All flight crew members required to be on flight deck duty shall remain at their stations except when their absence is necessary for the performance of duties in connection with the operation of the aeroplane or for physiological needs.

- (c) Seat belts.

All flight crew members shall keep their seat belts fastened when at their stations.

- (d) Safety harness.

When safety harnesses are provided, any flight crew member occupying a pilot's seat shall keep the safety harness fastened during the take-off and landing phases; all other flight crew members shall keep their safety harnesses fastened during the take-off and landing phases unless the shoulder straps interfere with the performance of their duties, in which case the shoulder straps may be unfastened but the seat belt must remain fastened.

Note: Safety harness includes shoulder strap(s) and a seat belt which may be used independently.

OPS 2A.219 Use of Oxygen

The pilot-in-command shall ensure that he/she and flight crew members engaged in performing duties essential to the safe operation of an aeroplane in flight use supplemental oxygen continuously whenever the cabin altitude exceeds 10000 ft for a period of more than 30 minutes and whenever the cabin altitude exceeds 13000 ft.

Note 1: Cabin crew should be safeguarded so as to ensure reasonable probability of their retaining consciousness during any emergency descent which may be necessary in the event of loss of pressurization and, in addition, they should have such means of protection as will enable them to administer first aid to passengers during stabilized flight following the emergency. Passengers should be safeguarded by such devices or operational procedures as will ensure reasonable probability of their surviving the effects of hypoxia in the event of loss of pressurization.

Note 2: It is not envisaged that cabin crew will always be able to provide assistance to passengers during emergency descent procedures which may be required in the event of loss of pressurization.

OPS 2A.221 In-flight Fuel Management

- (a) The pilot-in-command shall monitor the amount of usable fuel remaining on board to ensure it is not less than the fuel required to proceed to an aerodrome where a safe landing can be made with the planned final reserve fuel remaining.

Note: The protection of final reserve fuel is intended to ensure safe landing at any aerodrome when unforeseen occurrences may not permit a safe completion of an operation as originally planned.



- (b) The pilot-in-command shall advise ATC of a minimum fuel state by declaring MINIMUM FUEL when, having committed to land at a specific aerodrome, the pilot calculates that any change to the existing clearance to that aerodrome, or other air traffic delays, may result in landing with less than the planned final reserve fuel.

Note: The declaration of MINIMUM FUEL informs ATC that all planned aerodrome options have been reduced to a specific aerodrome that no aerodrome is available, and any change to the existing clearance, or air traffic delays, may result in landing with less than the planned final reserve fuel. This is not an emergency situation but an indication that an emergency situation is possible should any additional delay occur.

- (c) The pilot-in-command shall declare a situation of fuel emergency by broadcasting MAYDAY MAYDAY, MAYDAY, FUEL, when the calculated usable fuel estimated to be available upon landing at the nearest landing site where a safe landing can be made is less than the required final reserve fuel in compliance with OPS 2A.211.

Note 1: The planned final reserve fuel is the minimum amount of fuel required upon landing. The declaration of MAYDAY, MAYDAY, MAYDAY, FUEL informs ATC that all available landing options have been reduced to a specific aerodrome and a portion of the final reserve fuel may be consumed prior to landing.

Note 2: The pilot estimates with reasonable certainty that the fuel remaining upon landing at the nearest aerodrome will be less than the final reserve fuel taking into consideration the latest information available to the pilot, the area to be overflown, meteorological conditions and other reasonable contingencies.

- (d) The use of fuel after flight commencement for purposes other than originally intended during pre-flight planning shall require a re-analysis and, if applicable, adjustment of the planned operation.

OPS 2A.222 Instrument Approach Procedures

- (a) One or more instrument approach procedures designed to support instrument approach operations shall be approved and promulgated by the State in which the aerodrome is located to serve each instrument runway or aerodrome utilised for instrument flight operations.
- (b) Aeroplane operated in accordance with the instrument flight rules shall comply with the instrument approach procedures approved by the State in which the aerodrome is located.

OPS 2A.223 Duties of Pilot-in-Command

- (a) The pilot-in-command shall be responsible for the operation, safety and security of the aeroplane and the safety of all crew members, passengers and cargo on board.
- (b) The pilot-in-command shall be responsible for ensuring that a flight;
- (1) will not be commenced if any flight crew member is incapacitated from performing duties by any cause such as injury, sickness, fatigue or the effects of any psychoactive substance;
 - (2) will not be continued beyond the nearest weather-permissible aerodrome or operating site when a flight crew member's capacity to perform functions is significantly reduced by impairment of faculties from causes such as fatigue, sickness or lack of oxygen;



- (c) The pilot-in-command shall be responsible for notifying the nearest appropriate authority by the quickest available means of any accident involving the aeroplane that results in serious injury or death of any person or substantial damage to the aeroplane or property.
- (d) When undue proximity to the ground is detected by the pilot-in-command or by a ground proximity warning system, the pilot-in-command shall take corrective action immediately in order to establish safe flight conditions.
- (e) The pilot-in-command of an aeroplane shall notify the operator and the Authority as soon as practicable, or within 72 hours, of any event which constitutes an occurrence as described below and which comes to that person's attention in the exercise of that person's functions.
 - (1) Any incident relating to such an aeroplane or any defect in or malfunctioning of such an aeroplane or any part or equipment of such an aeroplane, being an incident, malfunctioning or defect endangering, or which if not corrected would endanger, such an aeroplane or its occupants or any other person; or
 - (2) Any defect in or malfunctioning of any facility on the ground used or intended to be used for purposes of or in connection with the operation of such an aeroplane, being a defect or malfunctioning endangering, or which if not corrected would endanger, such an aeroplane or its occupants; or
 - (3) Any incident in flight in which the pilot-in-command of an aeroplane has reason to believe that the aeroplane has been in collision with one or more than one bird.

OPS 2A.224 Cabin Baggage (Take-off and Landing)

The pilot shall ensure that all baggage carried onto an aeroplane and taken into the passenger cabin is adequately and securely stowed.

OPS 2A.226 Flight Operations Officer/Flight Dispatcher

Should any person be assigned as a flight operations officer/flight dispatcher, the operator shall ensure that person is trained and maintains familiarisation with all features of the operation which are pertinent to their duties, including knowledge and skills related to Human Factors.

**SUBPART D****AEROPLANE PERFORMANCE OPERATING LIMITATIONS****OPS 2A.301 General**

An aeroplane shall be operated;

- (a) in compliance with the terms of its airworthiness certificate or equivalent approved document;
- (b) within the operating limitations prescribed by the certifying authority and the Authority, as the State of Registry; and
- (c) if applicable, within the mass limitations imposed by compliance with the applicable noise certification Standards in Annex 16, Volume I, unless otherwise authorised in exceptional circumstances for a certain aerodrome or a runway where there is no noise disturbance problem, by the competent authority of the State in which the aerodrome is situated.

Note: Noise abatement procedures specified by the operator for any one aeroplane type should be the same for all aerodromes.

- (d) Placards, listings, instrument markings, or combinations thereof, containing those operating limitations prescribed by the Authority, as the State of Registry for visual presentation, shall be displayed in the aeroplane.
- (e) The pilot-in-command shall determine that aeroplane performance will permit the take-off and departure to be carried out safely.



This Page Intentionally Left Blank

**SUBPART E****INSTRUMENTS, EQUIPMENT AND FLIGHT DOCUMENTS****OPS 2A.401 General**

In addition to the minimum equipment necessary for the issuance of a certificate of airworthiness, the instruments, equipment and flight documents prescribed in the following paragraphs shall be installed or carried, as appropriate, in aeroplane according to the aeroplane used and to the circumstances under which the flight is to be conducted. The prescribed instruments and equipment, including their installation, shall be acceptable to the Authority as the State of Registry.

OPS 2A.402 Instruments and equipment - General

An aeroplane shall be equipped with instruments which will enable the flight crew to control the flight path of the aeroplane, carry out any required procedural manoeuvres and observe the operating limitations of the aeroplane in the expected operating conditions. An aeroplane on all flights shall be equipped with, or carry on board;

- (a) an accessible first-aid kit (Refer to AMC OPS 1.745 to CAR OPS 1 for example of contents);
- (b) portable fire extinguishers of a type which, when discharged, will not cause dangerous contamination of the air within the aeroplane. At least one shall be located in:
 - (1) the pilot's compartment; and
 - (2) each passenger compartment that is separate from the pilot's compartment and not readily accessible to the pilot or co-pilot; and
 - (3) Any agent used in a built-in fire extinguisher for each lavatory disposal receptacle for towels, paper or waste in an aeroplane for which the individual certificate of airworthiness is first issued on or after 31 December 2011 and any extinguishing agent used in a portable fire extinguisher in an aeroplane for which the individual certificate of airworthiness is first issued on or after 31 December 2018 shall:
 - (i) meet the applicable requirements of the Authority as the State of Registry; and
 - (ii) not be of a type listed in Annex A, Group II of the *Montreal Protocol on Substances That Deplete the Ozone Layer*, 8th Edition, 2009.
- (c)
 - (1) a seat or berth for each person who is aged 24 months or more; and
 - (2) a seat belt for each seat and restraining belts for each berth;
- (d) the following manuals, charts and information:
 - (1) the flight manual or other documents or information concerning any operating limitations prescribed for the aeroplane by the certifying authority of the State of Registry, required for the application of OPS 2A, Part I, Subpart C;
 - (2) any specific approval issued by the Authority under OPS 2A.003 for the operation(s) to be conducted.



- (3) current and suitable charts for the route of the proposed flight and all routes along which it is reasonable to expect that the flight may be diverted;
 - (4) procedures, as prescribed in CAR OPS 0, for pilots-in-command of intercepted aeroplane;
 - (5) ground-air signal codes for search and rescue purposes;
 - (6) a list of visual signals for use by intercepting and intercepted aeroplane, as contained in CAR OPS 0; and
 - (7) the journey log book for the aeroplane.
- (e) where the aeroplane is fitted with fuses that are accessible in flight, spare electrical fuses of appropriate ratings for replacement of those fuses.
- (f) A flight shall not be commenced when any of the aeroplane’s instruments, items of equipment or functions required for the intended flight are inoperative or missing, unless:
- (1) the aeroplane is operated in accordance with the MEL, if established; or
 - (2) the aeroplane is subject to a permit to fly issued in accordance with the applicable airworthiness requirements.

OPS 2A.403 Marking of break-in points

- (a) If areas of the fuselage suitable for break-in by rescue crews in emergency are marked on an aeroplane such areas shall be marked as shown below (see figure following). The colour of the markings shall be red or yellow, and if necessary they shall be outlined in white to contrast with the background.
- (b) If the corner markings are more than 2 m apart, intermediate lines 9 cm x 3 cm shall be inserted so that there is no more than 2 m between adjacent markings.

Note: This regulation does not require any aeroplane to have break-in areas.

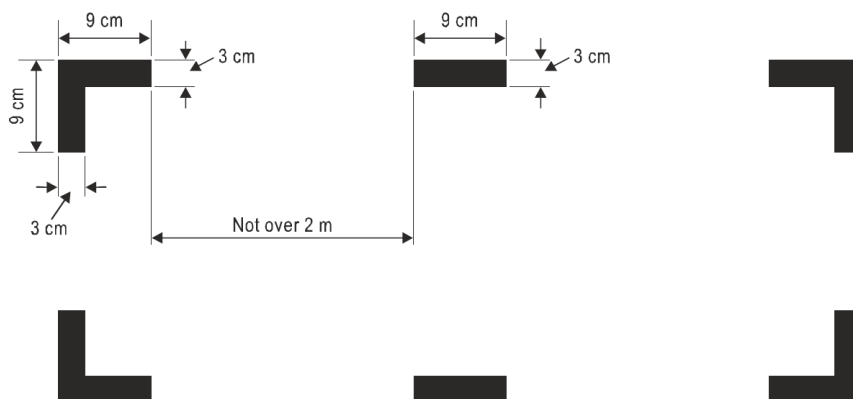

OPS 2A.404 Instruments and equipment - Day VFR

Aeroplane operated under VFR by day shall;

- (a) be equipped with a means of measuring and displaying the following;
 - (1) magnetic heading,



- (2) barometric altitude,
 - (3) indicated airspeed,
 - (4) mach number, whenever speed limitations are expressed in terms of Mach number; and
 - (5) such additional equipment as may be prescribed by the Authority.
- (b) Equipped with, or shall carry, a means of measuring and displaying the time in hours, minutes and seconds.
- (c) VFR flights which are operated as controlled flights should be equipped in accordance with OPS 2A.408

OPS 2A.406 Instruments and equipment - Night VFR

Aeroplane operated under visual meteorological conditions (VMC) at night, or in conditions where the aeroplane cannot be maintained in a desired flight path without reference to one or more additional instruments shall be, in addition to OPS 2A.407, equipped with:

- (a) a means of measuring and displaying the following:
- (1) turn and slip,
 - (2) attitude,
 - (3) vertical speed, and
 - (4) stabilised heading; and
 - (5) outside air temperature;
- (b) a means of indicating when the supply of power to the gyroscopic instruments is not adequate.
- (c) a means of preventing malfunction of the airspeed indicating system due to condensation or icing.

OPS 2A.407 Operating Lights for Night Operations

(See Appendix 1 to OPS 2A.407)

Aeroplane operated at night shall be equipped with;

- (a) the equipment specified in OPS 2A.408, and
- (b) the lights required by Appendix 1 to OPS 2A.407 for aircraft in flight or operating on the movement area of an aerodrome; and
- (c) an anti-collision light system;
- (d) navigation/position lights;
- (e) a landing light;



- (f) lighting supplied from the aeroplane's electrical system to provide adequate illumination for all instruments and equipment essential to the safe operation of the aeroplane that are used by the flight crew;
- (g) lighting supplied from the aeroplane's electrical system to provide illumination in all passenger compartments;
- (h) an independent portable light for each crew member station.

OPS 2A.408 Instruments and Equipment - IFR

All aeroplanes when operated in accordance with the instrument flight rules, or when the aeroplane cannot be maintained in a desired attitude without reference to one or more flight instruments, shall be;

- (a) equipped with a means of measuring and displaying the following:
 - (1) magnetic heading (standby compass),
 - (2) barometric altitude,
 - (3) indicated airspeed, with a means of preventing malfunctioning due to either condensation or icing;
 - (4) rate of climb and descent,
 - (5) turn and slip,
 - (6) aeroplane attitude,
 - (7) stabilised aeroplane heading,
 - (8) a means of indicating on the flight deck the outside air temperature,
 - (9) mach number, whenever speed limitations are expressed in terms of mach number; and

Note: The requirements of (5), (6) and (7) may be met by combinations of instruments or by integrated flight director systems provided that the safeguards against total failure, inherent in the three separate instruments, are retained.
- (b) equipped with, or shall carry, a means of measuring and displaying the time in hours, minutes and seconds.
- (c) equipped with a means of indicating when the supply of power to the gyroscopic instruments is adequate; and
- (d) equipped with such additional instruments or equipment as may be prescribed by the Authority.

OPS 2A.409 Flight Over Water

- (a) Single-engined landplanes;
 - (1) when flying over water beyond gliding distance from land; or



- (2) when taking off or landing at an aerodrome or operating site where, in the opinion of the pilot-in-command, the take-off or approach path is so disposed over water that there would be a likelihood of a ditching;

should be equipped with a life-jacket for each person on board, or equivalent individual floatation device for each person on board that shall be worn or stowed in a position that is readily accessible from the seat or berth of the person for whose use it is provided.

Note: "Landplanes" includes amphibians operated as landplanes.

- (b) Seaplanes operated over water shall be equipped with:

- (1) a life-jacket for each person on board, or equivalent individual floatation device for each person on board that shall be worn or stowed in a position that is readily accessible from the seat or berth of the person for whose use it is provided.
- (2) one anchor;
- (3) one sea anchor (drogue), when necessary to assist in manoeuvring; and
- (4) equipment for making the sound signals, as prescribed in the International Regulations for Preventing Collisions at Sea, where applicable.

Note: "Seaplanes" includes amphibians operated as seaplanes.

OPS 2A.411 Aeroplanes on Extended Flights Over Water

Note: An extended flight over water is defined as a distance of more than 50 NM (93 km) or 30 minutes at normal cruising speed, whichever is the lesser, away from land suitable for making an emergency landing.

- (a) An aeroplane operated on an extended flight over water shall be equipped with, at a minimum, one life jacket or equivalent individual floatation device for each person on board, stowed in a position easily accessible from the seat or berth of the person for whose use it is provided.
- (b) The pilot-in-command of an aeroplane operated on an extended flight over water shall determine the risks to survival of the occupants of the aeroplane in the event of a ditching by taking into account the operating environment and conditions such as, but not limited to, sea state and sea and air temperatures, the distance from land suitable for making an emergency landing, and the availability of search and rescue facilities. Based upon that assessment, he/she shall, in addition to the equipment required in paragraph (a) above, ensure that the aeroplane is equipped with:
 - (1) life-rafts in sufficient numbers to carry all persons on board, stowed so as to facilitate their ready use in emergency; and provided with such life-saving equipment, including means of sustaining life, as appropriate to the flight to be undertaken; and
 - (2) equipment for making the distress signals described in CAR OPS 0.

**OPS 2A.412 Aeroplanes on Flights Over Designated Land Areas**

Aeroplanes, when operated across land areas which have been designated by the State concerned as areas in which search and rescue would be especially difficult, shall be equipped with such signalling devices and life-saving equipment (including means of sustaining life) as may be appropriate to the area overflown.

OPS 2A.413 Supplemental Oxygen — Pressurised Aeroplane

- (a) Pressurised aeroplane operated at flight altitudes for which the oxygen supply is required shall be equipped with oxygen storage and dispensing apparatus capable of storing and dispensing the required oxygen supplies.
- (b) Pressurised aeroplane operated above flight altitudes at which the pressure altitude in the passenger compartments is above 10000 ft shall carry enough breathing oxygen to supply:
 - (1) all crew members and:
 - (i) 100 % of the passengers for any period when the cabin pressure altitude exceeds 15000 ft, but in no case less than 10 minutes' supply.
 - (ii) at least 30 % of the passengers, for any period when, in the event of loss of pressurisation and taking into account the circumstances of the flight, the pressure altitude in the passenger compartment will be between 14000 ft and 15000 ft; and
 - (iii) at least 10 % of the passengers for any period in excess of 30 minutes when the pressure altitude in the passenger compartment will be between 10000 ft and 14000 ft; and
 - (2) all the occupants of the passenger compartment for no less than 10 minutes, in the case of aeroplane operated at pressure altitudes above 25000 ft, or operated below that altitude but under conditions that will not allow them to descend safely to a pressure altitude of 13000 ft within 4 minutes.
- (c) Pressurised aeroplane operated at flight altitudes above 25000 ft shall, in addition, be equipped with a device to provide a warning indication to the flight crew of any loss of pressurisation.

OPS 2A.414 Supplemental Oxygen — Non-Pressurised Aeroplane

- (a) Non-pressurised aeroplane operated at flight altitudes when the oxygen supply is required shall be equipped with oxygen storage and dispensing apparatus capable of storing and dispensing the required oxygen supplies.
- (b) Non-pressurised aeroplane operated above flight altitudes at which the pressure altitude in the passenger compartments is above 10000 ft shall carry enough breathing oxygen to supply:
 - (1) all crew members and at least 10 % of the passengers for any period in excess of 30 minutes when the pressure altitude in the passenger compartment will be between 10000 ft and 13000 ft; and
 - (2) all crew members and passengers for any period that the pressure altitude in the passenger compartment will be above 13000 ft.

**OPS 2A.416 Noise Certification**

All aeroplane required to comply with the noise certification standards of ICAO Annex 16 shall carry a document attesting noise certification in the English language.

OPS 2A.417 Emergency locator transmitter (ELT)

- (a) Aeroplanes shall be equipped with;
 - (1) at least one ELT of any type;
 - (2) at least one automatic ELT, for those aeroplanes first issued with an individual C of A after 01 July 2008; or
 - (3) a survival ELT (ELT(S)) or a personal locator beacon (PLB), carried by the pilot-in-command or a passenger, when certified for a maximum passenger seating configuration of six or less.
- (b) ELTs of any type and PLBs shall be capable of transmitting simultaneously on 121.5 MHz and 406 MHz.
- (c) ELT equipment carried shall operate in accordance with the relevant provisions of ICAO Annex 10, Volume III.

OPS 2A.418 Pressure-Altitude Reporting Transponder

- (a) All aeroplanes shall be equipped with a pressure-altitude reporting transponder which operates in accordance with the relevant provisions of ICAO Annex 10, Volume IV.
- (b) Unless exempted by the appropriate authorities, aeroplanes operating as VFR flights shall be equipped with a pressure-altitude reporting transponder which operates in accordance with the relevant provision of Annex 10, Volume IV.

OPS 2A.419 Microphones

When operating under IFR all flight crew members required to be on flight deck duty should communicate through boom or throat microphones below the transition altitude.

OPS 2A.421 Aeroplane equipped with ALS, HUD or Equivalent Displays, EVS, SVS and/or CVS

Notwithstanding OPS 2A.203, where aeroplanes are equipped with automatic landing systems, a HUD and/or or equivalent displays, EVS, SVS or CVS, or any combination of those systems into a hybrid system, criteria for the use of such systems to gain operational benefit for the safe operation of the aeroplane shall be approved by the Authority. Such approvals shall not affect the classification of the instrument approach procedure.

OPS 2A.422 Ground proximity warning systems (GPWS)

- (a) All turbine-engined aeroplanes authorised to carry more than nine passengers shall be equipped with a ground proximity warning system which has a forward-looking terrain avoidance function.



- (b) A ground proximity warning system shall provide automatically a timely and distinctive warning to the flight crew when the aeroplane is in potentially hazardous proximity to the earth's surface.
- (c) A ground proximity warning system shall provide, at a minimum, warnings of at least the following circumstances:
- (1) excessive descent rate;
 - (2) excessive altitude loss after take-off or go-around; and
 - (3) unsafe terrain clearance.
- and should provide the warnings in sub-paragraph (d);
- (d) A ground proximity warning system installed in turbine-engined aeroplanes authorised to carry more than nine passengers for which the individual certificate of airworthiness was first issued after 01 January 2011 shall provide, as a minimum, warnings of at least the following circumstances;
- (1) excessive descent rate;
 - (2) excessive terrain closure rate;
 - (3) excessive altitude loss after take-off or go-around;
 - (4) unsafe terrain clearance while not in landing configuration;
 - (i) gear not locked down;
 - (ii) flaps not in a landing position; and
 - (5) excessive descent below the instrument glide path.

OPS 2A.423 Electronic Flight Bags (EFB)

- (a) Where portable EFBs are used on board an aeroplane, the pilot-in-command and/or the operator/owner shall ensure that they do not affect the performance of the aeroplane systems, equipment or the ability to operate the aeroplane.
- (b) Where EFBs are used on board an aeroplane the pilot-in-command and/or the owner shall;
- (1) assess the safety risk(s) associated with each EFB function;
 - (2) establish the procedures for the use of, and training requirements for, the device and each EFB function; and
 - (3) ensure that, in the event of an EFB failure, sufficient information is readily available to the flight crew for the flight to be conducted safely.
- (c) The Authority shall issue a specific approval for the operational use of EFB functions to be used for the safe operations of aeroplane.
- (d) When issuing a specific approval for the use of EFBs, the Authority shall ensure that:



- (1) the EFB equipment and its associated installation hardware, including interaction with aeroplane systems if applicable, meet the appropriate airworthiness certification requirements;
- (2) the operator/owner has assessed the risks associated with the operations supported by the EFB function(s);
- (3) the operator/owner has established requirements for redundancy of the information (if appropriate) contained and displayed by the EFB function(s);
- (4) the operator/owner has established and documented procedures for the management of the EFB function(s) including any databases it may use; and
- (5) the operator/owner has established and documented the procedures for the use of, and training requirements for, the EFB function(s).

Note: Guidance on EFB equipment, functions and establishing criteria for their operational use is contained in the Manual on Electronic Flight Bags (EFBs) (Doc 10020).

OPS 2A.424 Documents to be Carried

Every aeroplane engaged in international navigation shall carry the following documents;

- (a) Its certificate of registration;
- (b) Its certificate of airworthiness;
- (c) [The appropriate licences, medical certificates and validations, if applicable, for each member of the crew;]
- (d) Its journey log book;
- (e) [The Specific Approval, as required by OPS 2A.104.]
- (f) If it is equipped with radio apparatus, the aeroplane radio station licence;
- (g) If it carries passengers, a list of their names and places of embarkation and destination; and
- (h) If it carries cargo, a manifest and detailed declarations of the cargo.
- (i) A certified true copy of the agreement summary, when operating under an Article 83 bis agreement.

Note 1: [The operations manual procedures for the carriage of an electronic version of the documents listed above must be acceptable to the Authority.]

Note 2: The Certificate of Registration and the Certificate of Airworthiness are presented in digital format. They satisfy the on-board carriage requirements for aircraft engaged in international air navigation in accordance with Articles 29 and 31 of the Convention on International Civil Aviation as well as the requirements of Annex 7 and 8 to the same Convention.



Appendix 1 to OPS 2A.407
Lights To Be Displayed By Aeroplanes
(See OPS 2A.407)

1. TERMINOLOGY

When the following terms are used in this Appendix, they have the following meanings:

Angles of coverage.

- (a) Angle of coverage A is formed by two intersecting vertical planes making angles of 70 degrees to the right and 70 degrees to the left respectively, looking aft along the longitudinal axis to a vertical plane passing through the longitudinal axis.
- (b) Angle of coverage F is formed by two intersecting vertical planes making angles of 110 degrees to the right and 110 degrees to the left respectively, looking forward along the longitudinal axis to a vertical plane passing through the longitudinal axis.
- (c) Angle of coverage L is formed by two intersecting vertical planes, one parallel to the longitudinal axis of the aeroplane, and the other 110 degrees to the left of the first, when looking forward along the longitudinal axis.
- (d) Angle of coverage R is formed by two intersecting vertical planes, one parallel to the longitudinal axis of the aeroplane, and the other 110 degrees to the right of the first, when looking forward along the longitudinal axis.

Horizontal plane. The plane containing the longitudinal axis and perpendicular to the plane of symmetry of the aeroplane.

Longitudinal axis of the aeroplane. A selected axis parallel to the direction of flight at a normal cruising speed, and passing through the centre of gravity of the aeroplane.

Making way. An aeroplane on the surface of the water is “making way” when it is under way and has a velocity relative to the water.

Under command. An aeroplane on the surface of the water is “under command” when it is able to execute manoeuvres as required by the International *Regulations for Preventing Collisions at Sea* for the purpose of avoiding other vessels.

Under way. An aeroplane on the surface of the water is “under way” when it is not aground or moored to the ground or to any fixed object on the land or in the water.

Vertical planes. Planes perpendicular to the horizontal plane.

Visible. Visible on a dark night with a clear atmosphere.

2. NAVIGATION LIGHTS TO BE DISPLAYED IN THE AIR

As illustrated in Figure 1, the following unobstructed navigation lights shall be displayed:

- (a) a red light projected above and below the horizontal plane through angle of coverage L;
- (b) a green light projected above and below the horizontal plane through angle of coverage R;



- (c) a white light projected above and below the horizontal plane rearward through angle of coverage A.

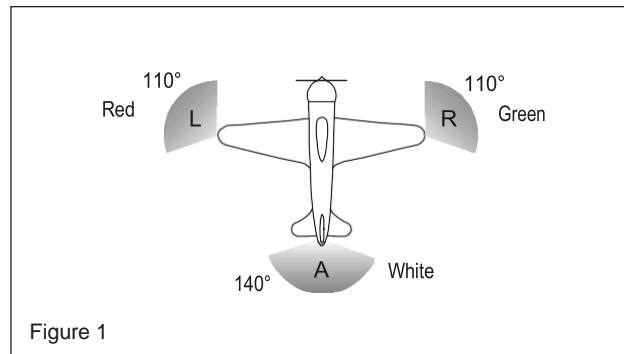

3. LIGHTS TO BE DISPLAYED ON THE WATER

3.1 General

The International Regulations for Preventing Collisions at Sea require different lights to be displayed in each of the following circumstances:

- (a) when under way;
- (b) when towing another vessel or aeroplane;
- (c) when being towed;
- (d) when not under command and not making way;
- (e) when making way but not under command;
- (f) when at anchor;
- (g) when aground.

The lights required by aeroplanes in each case are described below.

3.2 When under way

As illustrated in Figure 2, the following appearing as steady, unobstructed lights:

- (a) a red light projected above and below the horizontal through angle of coverage L;
- (b) a green light projected above and below the horizontal through angle of coverage R;
- (c) a white light projected above and below the horizontal through angle of coverage A; and
- (d) a white light projected through angle of coverage F.

The lights described in (a), (b) and (c) should be visible at a distance of at least 3.7 km (2 NM). The light described in (d) should be visible at a distance of 9.3 km (5 NM) when fitted to an aeroplane of 20 m or more in length or visible at a distance of 5.6 km (3 NM) when fitted to an aeroplane of less than 20 m in length.



3.3 When towing another vessel or aeroplane

As illustrated in Figure 3, the following appearing as steady, unobstructed lights:

- (a) the lights described in 3.2;
- (b) a second light having the same characteristics as the light described in 3.2 (d) and mounted in a vertical line at least 2 m above or below it; and
- (c) a yellow light having otherwise the same characteristics as the light described in 3.2 (c) and mounted in a vertical line at least 2 m above it.

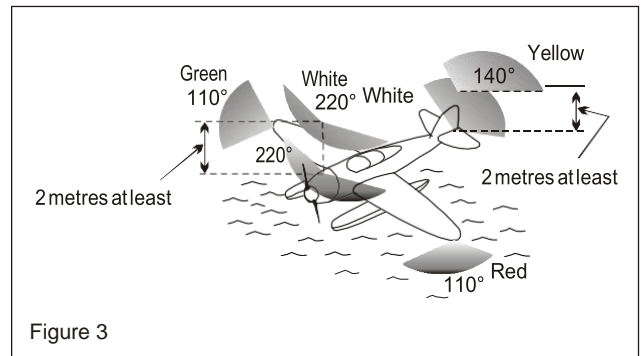
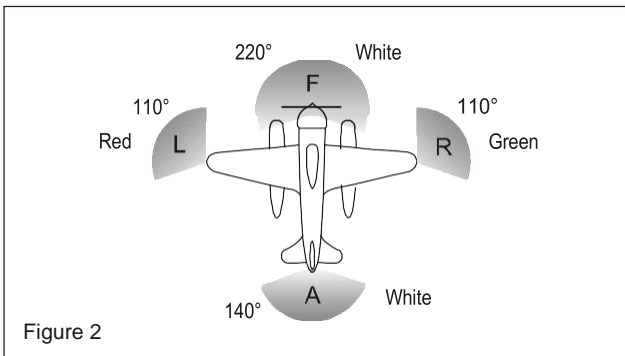

3.4 When being towed

The lights described in 3.2 (a), (b) and (c) appearing as steady, unobstructed lights.

3.5 When not under command and not making way

As illustrated in Figure 4, two steady red lights placed where they can best be seen, one vertically over the other and not less than 1 m apart, and of such a character as to be visible all around the horizon at a distance of at least 3.7 km (2 NM).

3.6 When making way but not under command

As illustrated in Figure 5, the lights described in 3.5 plus the lights described in 3.2 (a), (b) and (c).

Note: The display of lights prescribed in 3.5 and 3.6 is to be taken by other aircraft as signals that the aeroplane showing them is not under command and cannot therefore get out of the way. They are not signals of aeroplanes in distress and requiring assistance.

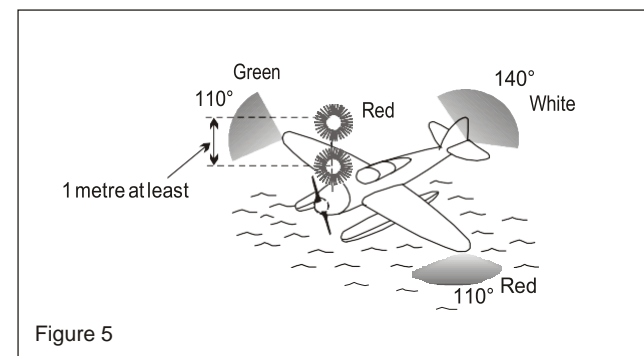
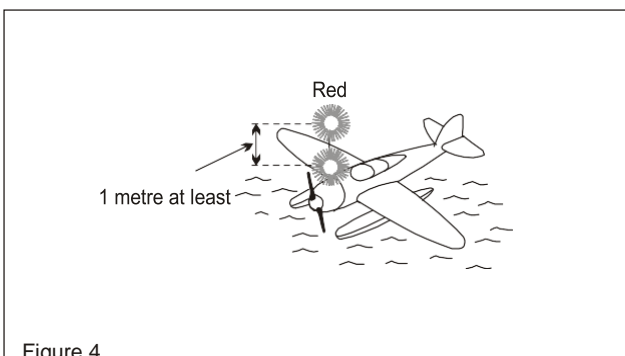



3.7 When at anchor

- (a) If less than 50 m in length, where it can best be seen, a steady white light (Figure 6), visible all around the horizon at a distance of at least 3.7 km (2 NM).
- (b) If 50 m or more in length, where they can best be seen, a steady white forward light and a steady white rear light (Figure 7) both visible all around the horizon at a distance of at least 5.6 km (3 NM).

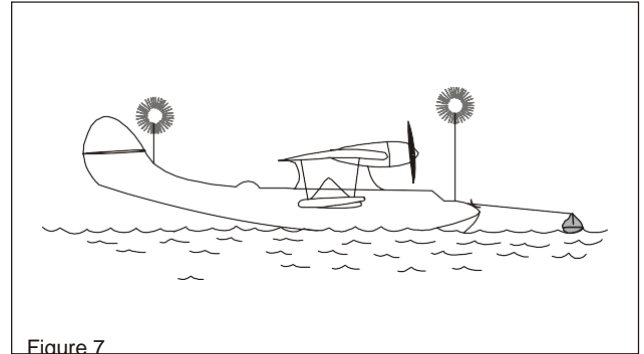
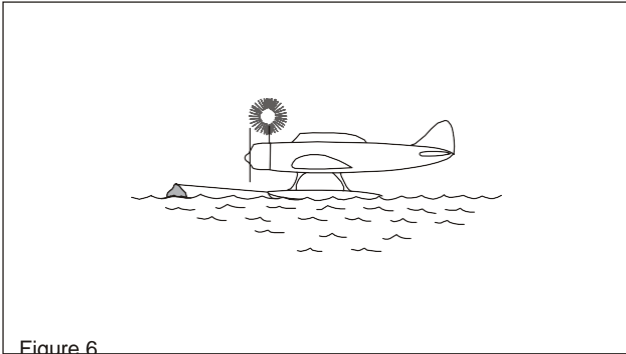

- (c) If 50 m or more in span a steady white light on each side (Figures 8 and 9) to indicate the maximum span and visible, so far as practicable, all around the horizon at a distance of at least 1.9 km (1 NM).

3.8 When aground

The lights prescribed in 3.7 and in addition two steady red lights in vertical line, at least 1 m apart so placed as to be visible all around the horizon.

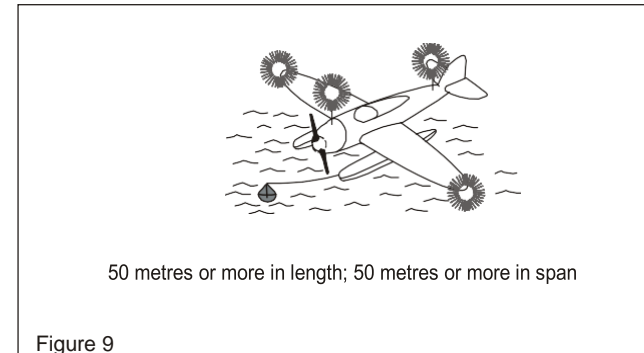
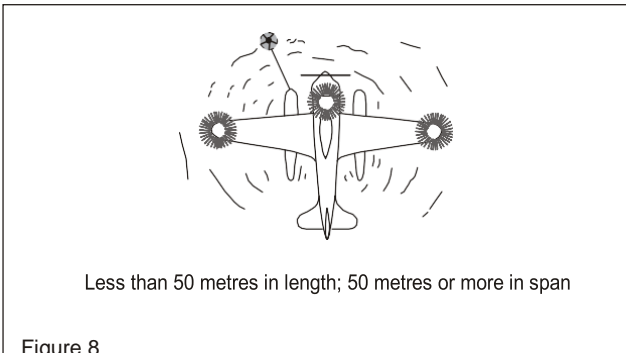



This Page Intentionally Left Blank

**SUBPART F****COMMUNICATION, NAVIGATION AND SURVEILLANCE EQUIPMENT****OPS 2A.501 Communication equipment**

- (a) An aeroplane to be operated in accordance with the instrument flight rules or at night shall be equipped with radio communication equipment capable of conducting two-way communication with those aeronautical stations and on those frequencies to meet airspace requirements.
- (b) When compliance with paragraph (a) requires that more than one communication equipment unit be provided, each shall be independent of the other or others to the extent that a failure in any one will not result in failure of any other.
- (c) An aeroplane to be operated in accordance with VFR, but as a controlled flight, shall, unless exempted by the appropriate authority, be provided with radio communication equipment capable of conducting two-way communication at any time during flight with such aeronautical stations and on such frequencies as may be prescribed by the appropriate authority.
- (d) An aeroplane to be operated on extended over water flights or flights over designated areas shall, unless exempted by the appropriate authority, be provided with radio communication equipment capable of conducting two-way communication at any time during flight with such aeronautical stations and on such frequencies as may be prescribed by the appropriate authority.
- (e) Radio communication equipment, if required by paragraphs (a) to (d) above, shall provide for communication on the aeronautical emergency frequency 121.5 MHz.
- (f) For operations where communication equipment is required to meet an RCP specification for performance-based communication (PBC), an aeroplane shall, in addition to the requirements specified above;
 - (1) be provided with communication equipment which will enable it to operate in accordance with the prescribed RCP specification(s);
 - (2) have information relevant to the aeroplane RCP specification capabilities listed in the flight manual or other aeroplane documentation, approved by the State of Design or State of Registry; and
 - (3) where the aeroplane is operated in accordance with a MEL, have information relevant to the aeroplane RCP specification capabilities included in the MEL.
- (g) The Authority, as the State of Registry, shall establish criteria for operations where an RCP specification for PBC has been prescribed.
- (h) When establishing criteria for operations where an RCP specification for PBC has been prescribed, ensure that the operator/owner has established and documented:
 - (1) normal and abnormal procedures, including contingency procedures;
 - (2) flight crew qualification and proficiency requirements, in accordance with appropriate RCP specifications;
 - (3) a training programme for relevant personnel consistent with the intended operations; and



- (4) appropriate maintenance procedures to ensure continued airworthiness, in accordance with appropriate RCP specifications.
- (i) The Authority shall ensure that, in respect of those aeroplanes mentioned in sub-paragraph (f) above, adequate provisions exist for:
 - (1) receiving the reports of observed communication performance issued by monitoring programmes; and
 - (2) taking immediate corrective action for individual aeroplane, aeroplane types or operators, identified in such reports as not complying with the RCP specification.

OPS 2A.502 Navigation equipment

- (a) An aeroplane shall be equipped with navigation equipment that will enable it to proceed in accordance with:
 - (1) the ATS flight plan, if applicable; and
 - (2) the requirements of air traffic services.

except when, if not so precluded by the appropriate authority, navigation for flights under VFR is accomplished by visual reference to landmarks.

- (b) An aeroplane shall have sufficient navigation equipment to ensure that, in the event of the failure of one item of equipment at any stage of the flight, the remaining equipment shall allow safe navigation in accordance with (a), or an appropriate contingency action, to be completed safely.
- (c) An aeroplane operated on flights in which it is intended to land in IMC shall be equipped with navigation equipment capable of providing guidance to a point from which a visual landing can be performed. This equipment shall be capable of providing such guidance for each aerodrome at which is intended to land in IMC and for any designated alternate aerodromes.

OPS 2A.503 Performance Based Navigation

- (a) For operations where a navigation specification for performance-based navigation (PBN) has been prescribed, an aeroplane shall, in addition to the requirements specified in OPS 2A.502:
 - (1) be provided with navigation equipment which will enable it to operate in accordance with the prescribed navigation specification(s);
 - (2) have information relevant to the aeroplane navigation specification capabilities listed in the flight manual or other aeroplane documentation, approved by the State of Design or State of Registry; and
 - (3) where the aeroplane is operated in accordance with a MEL, have information relevant to the aeroplane navigation specification capabilities included in the MEL.
- (b) The Authority, as the State of Registry, shall establish criteria for operations where a navigation specification for PBN has been prescribed.
- (c) When establishing criteria for operations where a navigation specification for PBN has been prescribed, ensure that the operator/owner has established and documented:



- (1) normal and abnormal procedures, including contingency procedures;
 - (2) flight crew qualification and proficiency requirements, in accordance with appropriate navigation specifications;
 - (3) a training programme for relevant personnel consistent with the intended operations; and
 - (4) appropriate maintenance procedures to ensure continued airworthiness, in accordance with appropriate navigation specifications.
- (d) The Authority, as the State of Registry, shall issue a specific approval for operations based on PBN authorisation required (AR) navigation specifications.

OPS 2A.504 NAT HLA

For flights in defined portions of the North Atlantic High Level Airspace where, based on regional air navigation agreement, minimum navigation performance specifications are prescribed, an aeroplane shall be provided with navigation equipment which:

- (a) continuously provides indications to the flight crew of adherence to or departure from track to the required degree of accuracy at any point along that track; and
- (b) has been authorised by the State of Registry for the NAT HLA operations concerned.

OPS 2A.506 RVSM

(See Appendix 1 to OPS 2A.506)

- (a) For flights in defined portions of airspace where, based on regional air navigation agreement, a reduced vertical separation minimum (RVSM) of 300 m (1000 ft) is applied between FL 290 and FL 410 inclusive, an aeroplane:
 - (1) shall be provided with equipment which is capable of:
 - (i) indicating to the flight crew the flight level being flown;
 - (ii) automatically maintaining a selected flight level;
 - (iii) providing an alert to the flight crew when a deviation occurs from the selected flight level. The threshold for the alert shall not exceed ± 90 m (300 ft); and
 - (iv) automatically reporting pressure-altitude;
 - (2) shall be issued with a specific approval by the Authority as the State of Registry for operation in the airspace concerned; and
 - (3) shall demonstrate a satisfactory vertical navigation performance in accordance with Appendix 1 to OPS 2A.506.
- (b) Prior to granting the RVSM specific approval required, the Authority shall be satisfied that:
 - (1) the vertical navigation performance capability of the aeroplane is satisfactory;



- (2) the owner/operator has instituted appropriate procedures in respect of continued airworthiness (maintenance and repair) practices and programmes; and
- (3) the owner/operator has instituted appropriate flight crew procedures for operations in RVSM airspace.

Note: A RVSM specific approval is valid globally on the understanding that any operating procedures specific to a given region will be stated in the programme operations manual or appropriate crew guidance.

- (c) The Authority as the State of Registry shall ensure that adequate provisions exist for:
 - (1) receiving the reports of height-keeping performance issued by the monitoring agencies; and
 - (2) taking immediate corrective action for individual aeroplane, or aeroplane type groups, identified in such reports as not complying with the height-keeping requirements for operation in airspace where RVSM is applied.
- (d) The Authority as the State of Registry that has issued an RVSM specific approval to an owner/operator shall establish a requirement which ensures that a minimum of two aeroplanes of each aeroplane type grouping of the owner/operator have their height-keeping performance monitored, at least once every two years or within intervals of 1000 flight hours per aeroplane, whichever period is longer. If an owner/operator aeroplane type grouping consists of a single aeroplane, monitoring of that aeroplane shall be accomplished within the specified period.
- (e) The Authority shall establish provisions and procedures which ensure that appropriate action will be taken in respect of aeroplane and owners/operators found to be operating in RVSM airspace without a valid RVSM specific approval.

OPS 2A.507 Surveillance Equipment

- (a) An aeroplane shall be provided with surveillance equipment which will enable it to operate in accordance with the requirements of air traffic services.
- (b) For operations where surveillance equipment is required to meet an RSP specification for performance-based surveillance (PBS), an aeroplane shall, in addition to the requirements specified in sub-paragraph (a);
 - (1) be provided with surveillance equipment which will enable it to operate in accordance with the prescribed RSP specification(s);
 - (2) have information relevant to the aeroplane RSP specification capabilities listed in the flight manual or other aeroplane documentation approved by the State of Design or Authority; and
 - (3) where the aeroplane is operated in accordance with a MEL, have information relevant to the aeroplane RSP specification capabilities included in the MEL.
- (c) The Authority, as the State of the Registry, shall establish criteria for operations where an RSP specification for PBS has been prescribed.
- (d) In establishing criteria for operations where an RSP specification for PBS has been prescribed, the Authority shall require that the operator/owner has established and documented;



- (1) normal and abnormal procedures, including contingency procedures;
 - (2) flight crew qualification and proficiency requirements, in accordance with appropriate RSP specifications;
 - (3) a training programme for relevant personnel consistent with the intended operations; and
 - (4) appropriate maintenance procedures to ensure continued airworthiness, in accordance with appropriate RSP specifications.
- (e) The Authority, as the State of Registry, shall ensure that, in respect of those aeroplane mentioned in sub-paragraph (b), adequate provisions exist for;
- (1) receiving the reports of observed surveillance performance issued by monitoring programmes; and
 - (2) taking immediate corrective action for individual aeroplane, aeroplane types or operators, identified in such reports as not complying with the RSP specification.



Appendix 1 to OPS 2A.506
Height-keeping Performance Requirements
(See OPS 2A.506)

1. In respect of groups of aeroplanes that are nominally of identical design and build with respect to all details that could influence the accuracy of height-keeping performance, the height-keeping performance capability shall be such that the total vertical error (TVE) for the group of aeroplanes shall have a mean no greater than 25 m (80 ft) in magnitude and shall have a standard deviation no greater than $28 - 0.013z^2$ for $0 \leq z \leq 25$ when z is the magnitude of the mean TVE in metres, or $92 - 0.004z^2$ for $0 \leq z \leq 80$ where z is in feet.
2. In addition, the components of TVE shall have the following characteristics:
 - (a) the mean altimetry system error (ASE) of the group shall not exceed 25 m (80 ft) in magnitude;
 - (b) the sum of the absolute value of the mean ASE and of three standard deviations of ASE shall not exceed 75 m (245 ft); and
 - (c) the differences between cleared flight level and the indicated pressure altitude actually flown shall be symmetric about a mean of 0 m, with a standard deviation no greater than 13.3 m (43.7 ft), and in addition, the decrease in the frequency of differences with increasing difference magnitude shall be at least exponential.
3. In respect of aeroplanes for which the characteristics of the airframe and altimetry system fit are unique and so cannot be classified as belonging to a group of aeroplanes encompassed by paragraph 1, the height-keeping performance capability shall be such that the components of the TVE of the aeroplane have the following characteristics:
 - (a) the ASE of the aeroplane shall not exceed 60 m (200 ft) in magnitude under all flight conditions; and
 - (b) the differences between the cleared flight level and the indicated pressure altitude actually flown shall be symmetric about a mean of 0 m, with a standard deviation no greater than 13.3 m (43.7 ft), and in addition, the decrease in the frequency of differences with increasing difference magnitude shall be at least exponential.

**SUBPART G****MAINTENANCE**

Note: For the purpose of this Subpart “aeroplane” includes: engines, propellers, components, accessories, instruments, equipment and apparatus including emergency equipment.

OPS 2A.601 Owner’s maintenance responsibilities

- (a) The owner of an aeroplane, or in the case where it is leased, the lessee, shall ensure, in accordance with the applicable regulations contained in CAR AIR, CAR GEN or CAR 21, that;
 - (1) the aeroplane is maintained in an airworthy condition;
 - (2) the operational and emergency equipment necessary for an intended flight is serviceable; and
 - (3) the certificate of airworthiness of the aeroplane remains valid.
- (b) The owner or the lessee shall not operate the aeroplane unless it is maintained and released to service under a system acceptable to the State of Registry.
- (c) The owner or the lessee shall not operate an aeroplane unless maintenance on the aeroplane, including any associated engine, propeller and part is carried out, and released to service by an organisation appropriately approved/accepted in accordance with CAR 145 except that pre-flight inspections need not necessarily be carried out by the CAR 145 organisation.
- (d) When the maintenance release is not issued by an approved maintenance organisation, the person signing the maintenance release shall be licensed in accordance with ICAO Annex 1.

[Note: Paragraph (d) is not applicable for aircraft operated according to CAR OPS 2.A Part III (Fractional Ownership Programme).]

- (e) The owner or the lessee shall ensure that the maintenance of the aeroplane is performed in accordance with a maintenance programme acceptable to the Authority as the State of Registry.
- (f) The owner or the lessee shall appoint an Airworthiness Coordinator who shall be responsible for the control of the maintenance system and the maintenance control manual, if applicable.

OPS 2A.602 Continuing airworthiness records

- (a) The owner of an aeroplane, or in the case where it is leased, the lessee, shall ensure that the continuing airworthiness records are kept for the periods specified in CAR GEN.058:
- (b) In the event of a temporary change of owner or lessee, the records shall be made available to the new owner or lessee. In the event of any permanent change of owner or lessee, the records shall be transferred to the new owner or lessee.
- (c) The operator shall ensure that a system has been established to keep, in a form and format that ensures readability, security and integrity of the records at all times and is acceptable to the Authority.



Note: The form and format of the records may include, for example, paper records, film records, electronic records or any combination thereof.

OPS 2A.603 Modifications and repairs

All modifications and repairs shall comply with airworthiness requirements acceptable to the Authority, as the State of Registry. Procedures shall be established to ensure that the substantiating data supporting compliance with the airworthiness requirements are retained.

OPS 2A.604 Maintenance release

- (a) A maintenance release shall be completed and signed, as prescribed by the Authority, as the State of Registry, to certify that the maintenance work performed has been completed satisfactorily and in accordance with data and procedures as stated in CAR GEN.
- (b) When maintenance is carried out by an approved maintenance organisation, the maintenance release shall be issued by the approved maintenance organisation in accordance with the provisions of CAR 145.
- (c) When maintenance is not carried out by an approved maintenance organisation, the maintenance release shall be completed and signed by a person appropriately licensed in accordance with ICAO Annex 1 to certify that the maintenance work performed has been completed satisfactorily and in accordance with approved data and the procedures as stated in CAR GEN.

**SUBPART H****FLIGHT CREW****OPS 2A.701 Composition of the flight crew**

The number and composition of the flight crew shall not be less than that specified in the flight manual or other documents associated with the certificate of airworthiness.

OPS 2A.702 Qualifications

- (a) The pilot-in-command shall:
- (1) ensure that each flight crew member holds a valid licence issued by the Authority, as the State of Registry, or if issued by another Contracting State, rendered valid by the Authority as the State of Registry;
 - (2) ensure that flight crew members are properly rated; and
 - (3) be satisfied that flight crew members have maintained competency.
- (b) The pilot-in-command of an aeroplane equipped with an airborne collision avoidance system (ACAS II) shall ensure that each flight crew member has been appropriately trained to competency in the use of ACAS II equipment and the avoidance of collision.



This Page Intentionally Left Blank

**SUBPART I****MANUALS LOGS & RECORDS****OPS 2A.801 Flight manual**

The aeroplane flight manual shall be updated by implementing changes made mandatory by the Authority as the State of Registry.

OPS 2A.802 Journey log book

A journey log book shall be maintained for every aeroplane engaged in international air navigation in which shall be entered particulars of the aeroplane, its crew and each journey.

Note: The aeroplane journey log should contain the following items:

- (a) aeroplane nationality and registration;*
- (b) date;*
- (c) crew member names and duty assignments;*
- (d) departure and arrival points and times;*
- (e) purpose of flight;*
- (f) observations regarding the flight; and*
- (g) signature of the pilot-in-command.*

OPS 2A.803 Records of emergency and survival equipment carried

The owner of the aeroplane, or in the case where it is leased, the lessee, shall at all times have available for immediate communication to rescue coordination centres, lists containing information on the emergency and survival equipment carried on board the aeroplane engaged in international air navigation. The information shall include, as applicable, the number, colour and type of life rafts and pyrotechnics, details of emergency medical supplies, water supplies and the type and frequencies of the emergency portable radio equipment.



This Page Intentionally Left Blank

**SUBPART J****SECURITY****OPS 2A.901 Security of aeroplane**

The pilot-in-command shall be responsible for the security of the aeroplane during its operation.

OPS 2A.902 Reporting acts of unlawful interference

Following an act of unlawful interference, the pilot-in-command shall submit a report of such an act to the designated local authority.

Note: In the context of this Subpart, the word "security" is used in the sense of prevention of acts of unlawful interference against civil aviation.



This Page Intentionally Left Blank



PART II

LARGE AND TURBOJET AEROPLANES



This Page Intentionally Left Blank



SUBPART A

APPLICABILITY

OPS 2A.005 Applicability

- (a) CAR OPS 2A, Part II states additional requirements for large and turbojet aeroplanes and applies to all general aviation operations. In addition to the regulations contained in OPS 2A Part I, General Aviation operators of the following aeroplanes shall also comply with the regulations contained in OPS 2A Part II.
- (1) an aeroplane;
 - (i) with a maximum certificated take-off mass exceeding 5700 kg; and
 - (ii) equipped with one or more turbojet engines; or
 - (iii) other aeroplanes as approved by the Authority.

OPS 2A.010 Leasing and Interchange

- (a) An operator may lease an aeroplane with flight crew to another person for a private operation for the following;
- (1) Ferry or training flights;
 - (2) Specialised operations such as aerial photography or survey, or pipeline patrol only;
 - (3) Flights for the demonstration of an aeroplane to prospective customers when no charge is made except for those specified in paragraph (c) of this section;
 - (4) Flights conducted by the operator of an aeroplane for his personal transportation, or the transportation of his guests when no charge, assessment, or fee is made for the transportation;
 - (5) Carriage of officials, employees, guests, and property of a company on an aeroplane operated by that company, or the parent or a subsidiary of the company or a subsidiary of the parent, when the carriage is within the scope of, and incidental to, the business of the company (other than transportation by air) and no charge, assessment or fee is made for the carriage in excess of the cost of owning, operating, and maintaining the aeroplane, except that no charge of any kind may be made for the carriage of a guest of a company, when the carriage is not within the scope of, and incidental to, the business of that company;
 - (6) The carriage of company officials, employees, and guests of the company on an aeroplane operated under a time sharing, interchange, or joint ownership agreement as defined in paragraph (b);
 - (7) The carriage of property (other than mail) on an aeroplane operated by a person in the furtherance of a business or employment (other than transportation by air) when the carriage is within the scope of, and incidental to, that business or employment and no charge, assessment, or fee is made for the carriage other than those specified in paragraph (c);



- (8) The carriage on an aeroplane of an athletic team, sports group, choral group, or similar group having a common purpose or objective when there is no charge, assessment, or fee of any kind made by any person for that carriage; and
 - (9) The carriage of persons on an aeroplane operated by a person in the furtherance of a business other than transportation by air for the purpose of selling them land, goods, or property, including franchises or distributorships, when the carriage is within the scope of, and incidental to, that business and no charge, assessment, or fee is made for that carriage.
- (b) For the purpose of paragraph (a);
- (1) A *time sharing agreement* means an arrangement whereby a person leases his/her aeroplane with flight crew to another person, and no charge is made for the flights conducted under that arrangement other than those specified in paragraph (c) of this section;
 - (2) An *interchange agreement* means an arrangement whereby a person leases his/her aeroplane to another person in exchange for equal time, when needed, on the other person's aeroplane, and no charge, assessment, or fee is made, except that a charge may be made not to exceed the difference between the cost of owning, operating, and maintaining the two airplanes;
 - (3) A *joint ownership agreement* means an arrangement whereby one of the registered joint owners of an aeroplane employs and furnishes the flight crew for that aeroplane and each of the registered joint owners pays a share of the charge specified in the agreement.
- (c) The following may be charged, as expenses of a specific flight, for transportation as authorised by paragraphs (a)(3) and (7) and (b)(1);
- (1) Fuel, oil, lubricants, and other additives.
 - (2) Travel expenses of the crew, including food, lodging, and ground transportation.
 - (3) Hangar and tie-down costs away from the aeroplane's base of operation.
 - (4) Insurance obtained for the specific flight.
 - (5) Landing fees, airport taxes, and similar assessments.
 - (6) Customs, foreign permit, and similar fees directly related to the flight.
 - (7) In flight food and beverages.
 - (8) Passenger ground transportation.
 - (9) Flight planning and weather contract services.
 - (10) An additional charge equal to 100% of the expenses listed in sub-paragraph (c)(1).

OPS 2A.015 Fractional Ownership Operations

- (a) [No person shall engage in a fractional ownership operation unless specifically approved by the Authority in accordance with CAR OPS 2A Part III and the management specifications issued by the Authority governing;



- (1) the provision of programme management services in a fractional ownership programme; and
- (2) the operation of a fractional ownership programme aircraft in a fractional ownership programme.]



This Page Intentionally Left Blank

**SUBPART B****GENERAL****OPS 2A.110 Compliance with Laws, Regulations and Procedures**

- (a) The operator shall ensure that all employees know that they must comply with the laws, regulations and procedures of those States in which operations are conducted.
- (b) The operator shall ensure that all pilots are familiar with the laws, regulations and procedures, pertinent to the performance of their duties, prescribed for the areas to be traversed, the aerodromes to be used and the air navigation facilities relating thereto.
- (c) The operator shall ensure that other members of the flight crew are familiar with such of these laws, regulations and procedures as are pertinent to the performance of their respective duties in the operation of the aeroplane.
- (d) The pilot-in-command is responsible for operational control. The operator shall describe the operational control system in the programme operations manual and identify the roles and responsibilities of those involved with the system.
- (e) The operator shall ensure that the pilot-in-command has available on board the aeroplane all the essential information concerning the search and rescue services in the area over which the aeroplane will be flown.
- (f) The operator shall ensure that flight crew members demonstrate the ability to speak and understand the English language.

OPS 2A.120 Safety Management System

(See Appendix 1 to OPS 2A.120)

- (a) The operator shall establish and maintain a safety management system that is appropriate to the size and complexity of the operation.
- (b) The SMS of the operator shall be established in accordance with the framework elements contained in Appendix 1 to OPS 2A.120.



This Page Intentionally Left Blank



Appendix 1 to OPS 2A.120
Framework for a Safety Management System (SMS)
(See OPS 2A.120)

This Appendix specifies the framework for the implementation and maintenance of an SMS. The framework comprises four components and twelve elements as the minimum requirements for SMS implementation:

1. Safety policy and objectives

1.1 Management commitment

1.1.1 The operator shall define its safety policy in accordance with international and national requirements. The safety policy shall:

- (a) reflect organisational commitment regarding safety, including the promotion of a positive safety culture;
- (b) include a clear statement about the provision of the necessary resources for the implementation of the safety policy;
- (c) include safety reporting procedures;
- (d) clearly indicate which types of behaviours are unacceptable related to the operator's aviation activities and include the circumstances under which disciplinary action would not apply;
- (e) be signed by the accountable manager or owner of the organisation;
- (f) be communicated, with visible endorsement, throughout the organisation; and
- (g) be periodically reviewed to ensure it remains relevant and appropriate to the operator.

1.1.2 Taking due account of its safety policy, the operator shall define safety objectives. The safety objectives shall:

- (a) form the basis for safety performance monitoring and measurement;
- (b) reflect the operator's commitment to maintain or continuously improve the overall effectiveness of the SMS;
- (c) be communicated throughout the organisation; and
- (d) be periodically reviewed to ensure they remain relevant and appropriate to the operator.

1.2 Safety accountability and responsibilities

The operator shall:

- (a) identify the accountable executive who, irrespective of other functions, is accountable on behalf of the organisation for the implementation and maintenance of an effective SMS;
- (b) clearly define lines of safety accountability throughout the organisation, including a direct accountability for safety on the part of senior management;



- (c) identify the responsibilities of all members of management, irrespective of other functions, as well as of employees, with respect to the safety performance of the organisation;
- (d) document and communicate safety accountability, responsibilities and authorities throughout the organisation; and
- (e) define the levels of management with authority to make decisions regarding safety risk tolerability.

1.3 Appointment of key safety personnel

The operator shall appoint a safety manager who is responsible for the implementation and maintenance of the SMS.

Note: Depending on the size of the operator and the complexity of its services, the responsibilities for the implementation and maintenance of the SMS may be assigned to one or more persons, fulfilling the role of safety manager, as their sole function or combined with other duties, provided these do not result in any conflicts of interest.

1.4 Coordination of emergency response planning

The operator required to establish and maintain an emergency response plan for accidents and incidents in aeroplane operations and other aviation emergencies shall ensure that the emergency response plan is properly coordinated with the emergency response plans of those organisations it must interface with during the provision of its services.

1.5 SMS documentation

1.5.1 The operator shall develop and maintain an SMS manual that describes its:

- (a) safety policy and objectives;
- (b) SMS requirements;
- (c) SMS processes and procedures; and
- (d) accountability, responsibilities and authorities for SMS processes and procedures.

1.5.2 The operator shall develop and maintain SMS operational records as part of its SMS documentation.

Note: Depending on the size of the operator and the complexity of its aviation services, the SMS manual and SMS operational records may be in the form of stand-alone documents or may be integrated with other organisational documents (or documentation) maintained by the operator.

2. Safety risk management

2.1 Hazard identification

2.1.1 The operator shall develop and maintain a process to identify hazards associated with its services.

2.1.2 Hazard identification shall be based on a combination of reactive and proactive methods.



2.2 Safety risk assessment and mitigation

The operator shall develop and maintain a process that ensures analysis, assessment and control of the safety risks associated with identified hazards.

Note: The process may include predictive methods of safety data analysis.

3. Safety assurance

3.1 Safety performance monitoring and measurement

3.1.1 The operator shall develop and maintain the means to verify the safety performance of the organisation and to validate the effectiveness of safety risk controls.

Note: An internal audit process is one means to monitor compliance with safety regulations, the foundation upon which SMS is built, and assess the effectiveness of these safety risk controls and the SMS.

3.1.2 The operator's safety performance shall be verified in reference to the safety performance indicators and safety performance targets of the SMS in support of the organisation's safety objectives.

3.2 The management of change

The operator shall develop and maintain a process to identify changes which may affect the level of safety risk associated with its services and to identify and manage the safety risks that may arise from those changes.

3.3 Continuous improvement of the SMS

The operator shall monitor and assess its SMS processes to maintain or continuously improve the overall effectiveness of the SMS.

4. Safety promotion

4.1 Training and education

4.1.1 The operator shall develop and maintain a safety training programme that ensures that personnel are trained and competent to perform their SMS duties.

4.1.2 The scope of the safety training programme shall be appropriate to each individual's involvement in the SMS.

4.2 Safety communication

The operator shall develop and maintain a formal means for safety communication that:

- (a) ensures personnel are aware of the SMS to a degree commensurate with their positions;
- (b) conveys safety-critical information;
- (c) explains why particular actions are taken to improve safety; and
- (d) explains why safety procedures are introduced or changed.

**Appendix 2 to OPS 2A.120****Principles for Protection of Safety Data, Safety Information and Related Sources
(See OPS 2A.120)****1. General principles**

- (a) The Authority shall, through national laws, regulations and policies protecting safety data, safety information and related sources, ensure that:
- (1) a balance is struck between the need for the protection of safety data, safety information and related sources to maintain or improve aviation safety, and the need for the proper administration of justice;
 - (2) safety data, safety information and related sources are protected in accordance with OPS 2A.106 and the Appendix to CAR ACC, Chapter 5, as applicable;
 - (3) the conditions under which safety data, safety information and related sources qualify for protection are specified; and
 - (4) safety data and safety information remain available for the purpose of maintaining or improving aviation safety.

2. Principles of protection

- (a) The Authority shall ensure that safety data or safety information is not used for:
- (1) disciplinary, civil, administrative and criminal proceedings against employees, operational personnel or organizations;
 - (2) disclosure to the public; or
 - (3) any purposes other than maintaining or improving safety;
- unless a principle of exception applies.
- (b) The Authority shall accord protection to safety data, safety information and related sources by ensuring that:
- (1) the protection is specified based on the nature of safety data and safety information;
 - (2) a formal procedure to provide protection to safety data, safety information and related sources is established;
 - (3) safety data and safety information will not be used in a way different from the purposes for which they were collected, unless a principle of exception applies; and
 - (4) to the extent that a principle of exception applies, the use of safety data and safety information in disciplinary, civil, administrative and criminal proceedings will be carried out only under authoritative safeguards.

Note 1: The formal procedure may include that any person seeking disclosure of safety data or safety information will provide the justification for its release.



Note 2: Authoritative safeguards include legal limitations or restrictions such as protective orders, closed proceedings, in-camera review, and de-identification of data for the use or disclosure of safety information in judicial or administrative proceedings.

3. Principles of exception

- (a) Exceptions to the protection of safety data, safety information and related sources shall only be granted when the Authority;
- (1) determines that there are facts and circumstances reasonably indicating that the occurrence may have been caused by an act or omission considered, in accordance with national laws, to be conduct constituting gross negligence, wilful misconduct or criminal activity;
 - (2) after reviewing the safety data or safety information, determines that its release is necessary for the proper administration of justice, and that the benefits of its release outweigh the adverse domestic and international impact such release is likely to have on the future collection and availability of safety data and safety information; or
 - (3) after reviewing the safety data or safety information, determines that its release is necessary for maintaining or improving safety, and that the benefits of its release outweigh the adverse domestic and international impact such release is likely to have on the future collection and availability of safety data and safety information.

Note 1: In administering the decision, the Authority takes into account the consent of the source of the safety data and safety information.

Note 2: Different competent authorities may be designated for different circumstances. The competent authority could include, but is not limited to, judicial authorities or those otherwise entrusted with aviation responsibilities designated in accordance with national law.

4. Public disclosure

- (a) The Authority shall, in the context of requests made for public disclosure, create exceptions from public disclosure to ensure the continued confidentiality of voluntarily supplied safety data and safety information.

Note: Laws, regulations and policies commonly referred to as right-to-know laws (freedom-of-information or open records) allow for public access to information held by the Authority.

- (b) Where disclosure is made in accordance with Section 3 above, the Authority shall ensure that:
- (1) public disclosure of relevant personal information included in the safety data or safety information complies with applicable privacy laws; or
 - (2) public disclosure of the safety data or safety information is made in a de-identified, summarized or aggregate form.

5. Responsibility of the custodian of safety data and safety information

The Authority shall ensure that each safety data collection and processing systems has a designated custodian to apply the protection to safety data and safety information in accordance with applicable provisions of these regulations.



Note: The “custodian” may refer to an individual or organisation.

6. Protection of recorded data

- (a) The Authority shall, through national laws and regulations, provide specific measures of protection regarding the confidentiality and access by the public to ambient workplace recordings.
- (b) The Authority shall, through national laws and regulations, treat ambient workplace recordings required by national laws and regulations as privileged protected data subject to the principles of protection and exception as provided for in these regulations.

Note 1: Ambient workplace recordings required by national laws, for example, cockpit voice recorders (CVRs) or recordings of background communication and the aural environment at air traffic controller work stations may be perceived as constituting an invasion of privacy for operational personnel that other professions are not exposed to.

Note 2: Provisions on the protection of flight recorder recordings and recordings from air traffic control units during investigations instituted are contained in ICAO Annex 13. Provisions on the protection of flight recorder recordings during normal operations are contained in OPS 2A.106.

**SUBPART C****FLIGHT OPERATIONS*****Operational Management (Before Flight)*****OPS 2A.205 Operating facilities**

- (a) The operator shall ensure that a flight will not be commenced unless it has been ascertained by every reasonable means available that the ground and/or water facilities including communication facilities and navigation aids available and directly required on such flight, for the safe operation of the aeroplane, are adequate for the type of operation under which the flight is to be conducted.

Note: "Reasonable means" in this regulation is intended to denote the use, at the point of departure, of information available to the operator either through official information published by the aeronautical information services or readily obtainable from other sources.

- (b) The operator, in making a decision on the adequacy of facilities and services available at an aerodrome of intended operation, shall assess the level of safety risk associated with the aircraft type and nature of the operation, in relation to the availability of rescue and firefighting services (RFFS).

OPS 2A.210 Operator notification

- (a) If the operator has an operating base in a State other than San Marino, as the State of Registry, the operator shall notify the State in which the operating base is located.
- (b) Upon notification in accordance with (a) above, safety and security oversight shall be coordinated between the State in which the operating base is located and the Authority as the State of Registry.

OPS 2A.215 Operations manual

(See Appendix 1 to OPS 2A.215)

- (a) The operator shall provide, for the use and guidance of personnel concerned, an operations manual containing all the instructions and information necessary for operations personnel to perform their duties.
- (b) The operations manual shall be amended or revised as is necessary to ensure that the information contained therein is kept up to date.
- (c) All such amendments or revisions shall be issued to all personnel that are required to use this manual.
- (d) The design of the manual should observe Human Factors principles.

OPS 2A.220 Operating instructions — general

The operator shall ensure that all operations personnel are properly instructed in their particular duties and responsibilities and the relationship of such duties to the operation as a whole.

Note: The operator should issue operating instructions and provide information on aeroplane climb performance to enable the pilot-in-command to determine the climb gradient that can be achieved during the departure phase for the existing take-off conditions and intended take-off technique. This



information should be included in the programme operations manual.

OPS 2A.225 In-flight simulation of emergency situations

The operator shall ensure that when passengers are being carried, no emergency or abnormal situations shall be simulated.

OPS 2A.230 Checklists

Checklists shall be used by flight crews prior to, during and after all phases of operations, and in emergencies, to ensure compliance with the operating procedures contained in the aeroplane operating manual and the aeroplane flight manual or other documents associated with the certificate of airworthiness and otherwise in the operations manual, are followed. The design and utilisation of checklists shall observe Human Factors principles.

OPS 2A.235 Minimum flight altitudes

The operator shall specify, for flights which are to be conducted in accordance with the instrument flight rules, the method of establishing terrain clearance altitudes.

OPS 2A.240 Fatigue management programme

The operator shall establish and implement a fatigue management programme that ensures that all operator personnel involved in the operation and maintenance of aeroplane do not carry out their duties when fatigued. The programme shall address flight and duty times and be included in the programme operations manual.

OPS 2A.245 Operational flight planning

The operator shall specify flight planning procedures to provide for the safe conduct of the flight based on considerations of aeroplane performance, other operating limitations and relevant expected conditions on the route to be followed and at the aerodromes concerned. These procedures shall be included in the programme operations manual.

OPS 2A.250 Take-off Alternate Aerodromes

- (a) A take-off alternate aerodrome shall be selected and specified in the flight plan if either the meteorological conditions at the aerodrome of departure are below the applicable aerodrome landing minima for that operation or if it would not be possible to return to the aerodrome of departure for other reasons.
- (b) The take-off alternate aerodrome shall be located within the following flight time from the aerodrome of departure:
 - (1) For aeroplanes with two engines - one hour of flight time at a one-engine-inoperative cruising speed determined from the aeroplane operating manual, calculated in ISA and still-air conditions using the actual take-off mass; or
 - (2) For aeroplanes with three or more engines - two hours of flight time at an all engines operating cruising speed determined from the aeroplane operating manual, calculated in ISA and still-air conditions using the actual take-off mass.



- (c) For an aerodrome to be selected as a take-off alternate the available information shall indicate that, at the estimated time of use, the conditions will be at or above the applicable aerodrome operating minima for that operation.

OPS 2A.255 Fuel requirements

- (a) An aeroplane shall carry a sufficient amount of usable fuel to complete the planned flight safely and to allow for deviations from the planned operation. The amount of usable fuel to be carried shall, as a minimum, be based on:

- (1) fuel consumption data:
 - (i) provided by the aeroplane manufacturer; or
 - (ii) if available, current aeroplane-specific data derived from a fuel consumption monitoring system; and
- (2) the operating conditions for the planned flight including:
 - (i) anticipated aeroplane mass;
 - (ii) Notices to Airmen;
 - (iii) current meteorological reports or a combination of current reports and forecasts;
 - (iv) air traffic services procedures, restrictions and anticipated delays; and
 - (v) the effects of deferred maintenance items and/or configuration deviations.

Note: Where no specific fuel consumption data exists for the precise conditions of the flight, the aeroplane may be operated in accordance with estimated fuel consumption data.

- (b) The pre-flight calculation of usable fuel required shall include:

- (1) *taxi fuel*, which shall be the amount of fuel expected to be consumed before take-off taking into account local conditions at the departure aerodrome and auxiliary power unit (APU) fuel consumption;
- (2) *trip fuel*, which shall be the amount of fuel required to enable the aeroplane to fly from take-off until landing at the destination aerodrome taking into account the operating conditions of (a) above;
- (3) *contingency fuel*, which shall be the amount of fuel required to compensate for unforeseen factors. It shall be not less than five per cent of the planned trip fuel;

Note: Unforeseen factors are those which could have an influence on the fuel consumption to the destination aerodrome, such as deviations of an individual aeroplane from the expected fuel consumption data, deviations from forecast meteorological conditions, extended delays and deviations from planned routings and/or cruising levels.

- (4) *destination alternate fuel*, which shall be:
 - (i) where a destination alternate aerodrome is required, the amount of fuel required to



enable the aeroplane to:

- (A) perform a missed approach at the destination aerodrome;
 - (B) climb to the expected cruising altitude;
 - (C) fly the expected routing;
 - (D) descend to the point where the expected approach is initiated; and
 - (E) conduct the approach and landing at the destination alternate aerodrome; or
- (ii) where a flight is operated without a destination alternate aerodrome, the amount of fuel required to enable the aeroplane to fly for 15 minutes at holding speed at 450 m (1 500 ft) above destination aerodrome elevation in standard conditions; or
 - (iii) where the aerodrome of intended landing is an isolated aerodrome:
 - (A) for a reciprocating engine aeroplane, the amount of fuel required to fly for 45 minutes plus 15 per cent of the flight time planned to be spent at cruising level, including final reserve fuel, or two hours, whichever is less; or
 - (B) for a turbine-engined aeroplane, the amount of fuel required to fly for two hours at normal cruise consumption above the destination aerodrome, including final reserve fuel;
- (5) *final reserve fuel*, which shall be the amount of fuel on arrival at the destination alternate aerodrome, or the destination aerodrome when no destination alternate aerodrome is required:
 - (i) for a reciprocating engine aeroplane, the amount of fuel required to fly for 45 minutes; or
 - (ii) for a turbine-engined aeroplane, the amount of fuel required to fly for 30 minutes at holding speed at 450 m (1 500 ft) above aerodrome elevation in standard conditions;
 - (6) *additional fuel*, which shall be the supplementary amount of fuel required to enable the aeroplane to descend as necessary and proceed to land at an alternate aerodrome in the event of engine failure or loss of pressurization based on the assumption that such a failure occurs at the most critical point along the route;
 - (7) *discretionary fuel*, which shall be the extra amount of fuel to be carried at the discretion of the pilot-in-command.
- (c) Operators should determine one final reserve fuel value for each aeroplane type and variant in their fleet rounded up to an easily recalled figure.
 - (d) The use of fuel after flight commencement for purposes other than originally intended during pre-flight planning shall require a re-analysis and, if applicable, adjustment of the planned operation.

Note: Nothing in OPS 2A.255 precludes the in-flight amendment of a flight plan to re-plan that flight to another aerodrome, provided that these requirements can be complied with from the point where the flight is re-planned.



OPS 2A.260 Refuelling with Passengers on Board

In addition to the requirements specified in OPS 2A.212, when refuelling with passengers embarking, on board or disembarking, two-way communication shall be maintained by the aeroplane's intercommunication system or other suitable means between the ground crew supervising the refuelling and the qualified personnel on board the aeroplane.

OPS 2A.265 Oxygen Supply

- (a) A flight to be operated at flight altitudes at which the cabin pressure in personnel compartments will be higher than 10000 ft shall not be commenced unless sufficient stored breathing oxygen is carried to supply:
 - (1) all crew members and 10 per cent of the passengers for any period in excess of 30 minutes that the cabin pressure in compartments occupied by them will be between 10000 ft and 13000 ft; and
 - (2) the crew and passengers for any period that the cabin pressure in compartments occupied by them will be greater than 13000 ft.
- (b) A flight to be operated with a pressurized aeroplane shall not be commenced unless a sufficient quantity of stored breathing oxygen is carried to supply all the crew members and passengers, as is appropriate to the circumstances of the flight being undertaken, in the event of loss of pressurization, for any period that the cabin pressure in any compartment occupied by them would be more than 10000 ft. In addition, when an aeroplane is operated at flight altitudes at which the atmospheric pressure is less than 376 hPa (25000 ft), or which, if operated at flight altitudes at which the atmospheric pressure is more than 376 hPa (25000 ft) and cannot descend safely within four minutes to a flight altitude at which the cabin pressure is equal to 13000 ft, there shall be no less than a 10-minute supply for the occupants of the passenger compartment.

In-flight procedures

OPS 2A.270 Use of Oxygen

- (a) All flight crew members, when engaged in performing duties essential to the safe operation of an aeroplane inflight, shall use breathing oxygen continuously whenever the circumstances prevail for which its supply has been required in OPS 2A.265.
- (b) All flight crew members of pressurised aeroplanes operating above an altitude where the atmospheric pressure is less than 376 hPa (25000 ft) shall have available at the flight duty station a quick-donning type of oxygen mask which will readily supply oxygen upon demand.

OPS 2A.275 Flight Recorder Operation

- (a) Flight recorders shall not be switched off during flight time.
- (b) To preserve flight recorder records, flight recorders shall be deactivated upon completion of flight time following an accident or incident. The flight recorders shall not be reactivated before their disposition as determined by the investigating authority.
- (c) The pilot-in-command, and/or the owner/operator, or in the case where it is leased, the lessee, shall ensure, to the extent possible, in the event the aeroplane becomes involved in an accident or incident, the preservation of all related flight recorder records, and if necessary the associated flight recorders,



and their retention in safe custody pending their disposition as determined by the investigating authority.

- (d) Operational checks and evaluations of recordings from the flight recorder systems shall be conducted to ensure the continued serviceability of the recorders.

OPS 2A.280 Procedure for Rate of Climb or Descent

Unless otherwise specified in an air traffic control instruction, to avoid unnecessary airborne collision avoidance system (ACAS II) resolution advisories in aeroplane at or approaching adjacent altitudes or flight levels, pilots should consider using appropriate procedures to ensure that a rate of climb or descent of less than 8 m/s or 1 500 ft/min (depending on the instrumentation available) is achieved throughout the last 300 m (1000 ft) of climb or descent to the assigned altitude or flight level, when made aware of another aeroplane at or approaching an adjacent altitude or flight level.

OPS 2A.285 Operating Procedures for Landing Performance

An approach to land shall not be continued below 300 m (1000 ft) above aerodrome elevation unless the pilot-in-command is satisfied that, with the runway surface condition information available, the aeroplane performance information indicates that a safe landing can be made.

OPS 2A.290 Duties of Pilot-in-Command

In addition to the duties of the pilot-in-command specified in OPS 2A.223;

- (a) The pilot-in-command shall ensure that the required checklists are complied with in detail.
- (b) The pilot-in-command shall be responsible for notifying the nearest appropriate authority by the quickest available means of any accident involving the aeroplane, resulting in serious injury or death of any person or substantial damage to the aeroplane or property. In the event that the pilot-in-command is incapacitated the operator shall take the forgoing action.
- (c) The pilot-in-command shall be responsible for reporting all known or suspected defects in the aeroplane, to the operator, at the termination of the flight.
- (d) The pilot-in-command shall be responsible for the journey log book or the general declaration containing the required information.

OPS 2A.295 In-flight Fuel Management

In addition to the requirements specified in OPS 2A.221;

- (a) The operator shall establish policies and procedures to ensure that in-flight fuel checks and fuel management are performed.
- (b) The pilot-in-command shall request delay information from ATC when unanticipated circumstances may result in landing at the destination aerodrome with less than the final reserve fuel plus any fuel required to proceed to an alternate aerodrome or the fuel required to operate to an isolated aerodrome.



Appendix 1 to OPS 2A.215
Content of a Programme Operations Manual
(See OPS 2A.215)

The following is the suggested content of a company programme operations manual. It may be issued in separate parts corresponding to specific aspects of an operation. It should include the instructions and information necessary to enable the personnel concerned to perform their duties safely and shall contain at least the following information:

- (a) table of contents;
- (b) amendment control page and list of effective pages, unless the entire document is reissued with each amendment and
- (c) the document has an effective date on it;
- (d) duties, responsibilities and succession of management and operating personnel;
- (e) operator safety management system;
- (f) operational control system;
- (g) MEL procedures (where applicable);
- (h) normal flight operations;
- (i) standard operating procedures (SOPs);
- (j) weather limitations;
- (k) flight and duty time limitations;
- (l) emergency operations;
- (m) accident/incident considerations;
- (n) personnel qualifications and training;
- (o) record keeping;
- (p) a description of the maintenance control system (refer also to OPS 2A.1605);
- (q) security procedures (where applicable);
- (r) performance operating limitations;
- (s) use/protection of FDR/CVR records (where applicable);
- (t) handling of dangerous goods;
- (u) use of automatic landing systems, a HUD or equivalent displays and EVS, SVS or CVS equipment as applicable; and



- (v) additional information requested by the Authority.

**SUBPART D****PERFORMANCE OPERATING LIMITATIONS****OPS 2A.310 Aeroplanes**

- (a) An aeroplane shall be operated in compliance with the terms of its certificate of airworthiness and within the approved operating limitations contained in its flight manual.
- (b) The Authority, as the State of Registry, shall take such precautions as are reasonably possible to ensure that the general level of safety contemplated by these provisions is maintained under all expected operating conditions, including those not covered specifically by the provisions of this Subpart.
- (c) A flight shall not be commenced unless the performance information provided in the flight manual indicates that OPS 2A.320 to OPS 2A.350 can be complied with for the flight to be undertaken.
- (d) In applying the requirements of this Subpart account shall be taken of all factors that significantly affect the performance of the aeroplane (such as: mass, operating procedures, the pressure altitude appropriate to the elevation of the aerodrome, runway slope, the ambient temperature, wind, and surface conditions of the runway at the expected time of use, i.e. presence of slush, water and/or ice, for landplanes, water surface condition for seaplanes). Such factors shall be taken into account directly as operational parameters or indirectly by means of allowances or margins, which may be provided in the scheduling of performance data or in the comprehensive and detailed code of performance in accordance with which the aeroplane is being operated.

OPS 2A.320 Mass limitations

- (a) The mass of the aeroplane at the start of take-off shall not exceed the mass at which OPS 2A.330 is complied with, nor the mass at which OPS 2A.340 and OPS 2A.350 are complied with, allowing for expected reductions in mass, for such fuel jettisoning or use of alternate aerodromes as the flight proceeds.
- (b) In no case shall the mass at the start of take-off exceed the maximum take-off mass specified in the flight manual for the pressure altitude appropriate to the elevation of the aerodrome, and if used as a parameter to determine the maximum take-off mass, any other local atmospheric condition.
- (c) In no case shall the estimated mass for the expected time of landing at the aerodrome of intended landing and at any destination alternate aerodrome, exceed the maximum landing mass specified in the flight manual for the pressure altitude appropriate to the elevation of those aerodromes, and if used as a parameter to determine the maximum landing mass, any other local atmospheric condition.
- (d) In no case shall the mass at the start of take-off, or at the expected time of landing at the aerodrome of intended landing and at any destination alternate aerodrome, exceed the relevant maximum masses at which compliance has been demonstrated with the applicable noise certification Standards in ICAO Annex 16, Volume I, unless otherwise authorised in exceptional circumstances for a certain aerodrome or a runway where there is no noise disturbance problem, by the competent authority of the State in which the aerodrome is situated.

OPS 2A.330 Take-off

- (a) The aeroplane shall be able, in the event of a critical engine failing at any point in the take-off, either to discontinue the take-off and stop within either the accelerate-stop distance available or the runway



available, or to continue the take-off and clear all obstacles along the flight path by an adequate margin until the aeroplane is in a position to comply with OPS 2A.340.

- (b) In determining the length of the runway available, account shall be taken of the loss, if any, of runway length due to alignment of the aeroplane prior to take-off.

OPS 2A.340 En-route — One Engine Inoperative

The aeroplane shall be able, in the event of the critical engine becoming inoperative at any point along the route or planned diversions therefrom, to continue the flight to an aerodrome at which OPS 2A.350 can be met, without flying below the minimum obstacle clearance altitude at any point.

OPS 2A.350 Landing

The aeroplane shall, at the aerodrome of intended landing and at any alternate aerodrome, after clearing all obstacles in the approach path by a safe margin, be able to land, with assurance that it can come to a stop or, for a seaplane, to a satisfactorily low speed, within the landing distance available. Allowance shall be made for expected variations in the approach and landing techniques, if such allowance has not been made in the scheduling of performance data.

**SUBPART E****INSTRUMENTS, EQUIPMENT AND FLIGHT DOCUMENTS****OPS 2A.405 General**

- (a) Where a master minimum equipment list (MMEL) is established for the aeroplane type, the operator shall include in the programme operations manual a minimum equipment list (MEL) approved by the Authority, as the State of Registry of the aeroplane, which will enable the pilot-in-command to determine whether a flight may be commenced or continued from any intermediate stop should any instrument, equipment or systems become inoperative.
- (b) A flight shall not be commenced when any of the aeroplane's instruments, items of equipment, or functions, required for the intended flight are inoperative or missing, unless:
- (1) the aeroplane is operated in accordance with the operator's minimum equipment list (MEL); or
 - (2) the operator is approved by the Authority to operate the aeroplane within the constraints of the master minimum equipment list (MMEL); or
 - (3) the aeroplane is subject to a permit to fly issued in accordance with the applicable airworthiness requirements.

OPS 2A.410 Aeroplanes on all Flights

In addition to the requirements contained in Part I, Subpart E, an aeroplane shall be equipped with:

- (a) accessible and adequate medical supplies appropriate to the number of passengers the aeroplane is authorised to carry.
- (b) first-aid kits.
- (c) a safety harness for each flight crew seat. The safety harness for each pilot seat shall incorporate a device which will automatically restrain the occupant's torso in the event of rapid deceleration;

Note 1: The safety harness for each pilot seat should incorporate a device to prevent a suddenly incapacitated pilot from interfering with the flight controls.

Note 2: Safety harness includes shoulder straps and a seat belt which may be used independently.

- (d) means of ensuring that the following information and instructions are conveyed to passengers:
 - (1) when seat belts are to be fastened;
 - (2) when and how oxygen equipment is to be used if the carriage of oxygen is required;
 - (3) restrictions on smoking;
 - (4) location and use of life jackets or equivalent individual flotation devices where their carriage is required;
 - (5) location of emergency equipment; and



- (6) location and method of opening emergency exits.

OPS 2A.415 Manuals and Checklists

An aeroplane shall carry:

- (a) the programme operations manual, or those parts of it that pertain to flight operations, including operating procedures for conducting instrument approaches;
- (b) the flight manual, or other documents containing required performance data and any other information necessary for the operation of the aeroplane within the terms of its certificate of airworthiness, unless these data are available in the programme operations manual; and
- (c) the checklists required by OPS 2A.230

OPS 2A.420 Cockpit Voice Recorder

(See Appendix 1 to OPS 2A.420/OPS 2A.430)

(See Appendix 1 to OPS 2A.420 to 2.430 inclusive)

(See Appendix 2 to OPS 2A.420 to 2.430 inclusive)

- (a) The following aeroplanes shall be equipped with a CVR:
 - (1) aeroplanes with an MCTOM of more than 27000 kg for which the individual certificate of airworthiness is first issued on or after 01 January 1987;
 - (2) turbine-engined aeroplanes with an MCTOM of more than 5700 kg, which are:
 - (i) certified to be operated with more than one pilots; and
 - (ii) for which a type certificate is first issued on or after 01 January 2016.
- (b) All CVRs shall retain the information recorded during at least the last 2 hours of their operation.
- (c) All aeroplanes of a maximum certificated take-off mass of over 27000 kg for which the individual certificate of airworthiness is first issued on or after 01 January 2022 shall be equipped with a CVR capable of retaining the information recorded during at least the last 25 hours of its operation.
- (d) CVRs and CARS shall not use magnetic tape or wire.
- (e) All aeroplanes that are required to be equipped with CARS, and for which the individual certificate of airworthiness is first issued on or after 01 January 2025, shall be equipped with a CARS which shall retain the information recorded during at least the last two hours of their operation.

OPS 2A.425 Flight Data Recorder

(See Appendix 1 to OPS 2A.420 to 2.430 inclusive)

(See Appendix 2 to OPS 2A.420 to 2.430 inclusive)

(See Appendix 1 to OPS 2A.425/OPS 2A.430)

(See Appendix 2 to OPS 2A.425/OPS 2A.430)

(See Appendix 1 to OPS 2A.425)

- (a) All multi-engine, turbine-powered aeroplanes of a MCTOM of over 5700 kg and having a passenger seating configuration, excluding any pilot seats of 10 or more, for which the individual certificate of airworthiness is first issued on or after 01 January 2005 shall be



equipped with a FDR capable of recording the parameters 1 – 78 listed in the Appendix 1 to OPS 2A.425 unless exempted under sub-paragraph (g) below;

- (b) All aeroplanes of a MCTOM of over 5700 kg and first issued with an individual certificate of airworthiness on or after 01 January 2016 shall be equipped with a FDR that uses a digital method of recording and storing data and for which a method of readily retrieving that data from the storage medium is available.
- (c) All aeroplanes of a maximum certificated take-off mass of over 5700 kg for which the application for type certification is submitted to a Contracting State on or after 01 January 2023 shall be equipped with a FDR capable of recording at least the 82 parameters listed in Appendix 1 to OPS 2A.425.
- (d) All aeroplanes of a maximum certificated take-off mass of over 27000 kg for which the individual certificate of airworthiness is first issued on or after 01 January 1989 shall be equipped with a FDR capable of recording the parameters 1 – 32 listed in the Appendix 1 to OPS 2A.435 unless exempted under sub-paragraph (g) below;
- (e) FDRs, ADRS, AIRs or AIRS shall not use engraving metal foil, frequency modulation (FM), photographic film or magnetic tape.
- (f) All FDRs shall retain the information recorded during at least the last 25 hours of their operation.
- (g) When FDRs are required to be installed, those FDRs that meet the current parameter certification requirements of the FAA, Transport Canada or EASA in respect to private air transport operations, shall be exempt from the parameter requirements of OPS 2A.425 and Appendix 1 to OPS 2A.425.

Note 1: “The application for type certification is submitted to a Contracting State” refers to the date of application of the original “Type Certificate” for the aeroplane type, not the date of certification of particular aeroplane variants or derivative models.

Note 2: The documentation requirement concerning FDR and ADRS parameters provided by operators to accident investigation authorities should be in electronic format and take account of industry specifications.

OPS 2A.430 Data Link Recording

(See Appendix 1 to OPS 2A.430)

- (a) All aeroplane for which the individual C of A is first issued on or after 01 January 2016 which use any of the data link communication application referred to in Appendix 1 to OPS 2A.430 and are required to carry a CVR shall record the data link communication messages on a crash-protected flight recorder.
- (b) All aeroplanes for which the individual certificate of airworthiness was first issued before 01 January, 2016, that are required to carry a CVR and are modified on or after 01 January 2016 to install and use any of the data link communication application referred to in Appendix 1 to OPS 2A.430 shall record the data link communication messages on a crash-protected flight recorder unless the installed the data link communication equipment is compliant with a type certificate issued or aircraft modification first approved prior to 01 January, 2016.

Note 1: A Class B AIR could be a means for recording data link communications applications messages to and from the aeroplane where it is not practical or is prohibitively expensive to



record those data link communications applications messages on FDR or CVR.

Note 2: The “aircraft modifications” refer to modifications to install the data link communications equipment on the aircraft (e.g. structural, wiring).

- (c) The recorder shall use a digital method of recording and storing data and information and a method for readily retrieving that data. The recording method shall allow the data to match the data recorded on the ground and also be correlated to the recorded cockpit audio.
- (d) The minimum recording duration shall be equal to the duration of the CVR.
- (e) The requirements applicable to the start and stop logic of the recorder are the same as the requirements applicable to the start and stop logic of the CVR contained in Appendix 1 to OPS 2A.430.

OPS 2A.435 Flight Data and Cockpit Voice Combination Recorder

Compliance with CVR requirements and FDR requirements may be achieved by:

- (a) one flight data and cockpit voice combination recorder if the aeroplane has to be equipped with a CVR or an FDR; or
- (b) two flight data and cockpit voice combination recorders if the aeroplane has to be equipped with a CVR and an FDR.

OPS 2A.440 Long-Range Over-Water Flights

In addition to the requirements specified in OPS 2A.411, each life jacket and equivalent individual flotation device shall be equipped with a means of electric illumination for the purpose of facilitating the location of persons, except for individual flotation devices other than life jackets.

OPS 2A.445 Icing Conditions

Aeroplanes shall be equipped with suitable de-icing and/or anti-icing devices when operated in circumstances in which icing conditions are reported to exist or are expected to be encountered.

OPS 2A.450 Operations in Accordance with the Instrument Flight Rules

In addition to the requirements contained in OPS 2A.408, aeroplanes when operated in accordance with the instrument flight rules or when the aeroplane cannot be maintained in a desired attitude without reference to one or more flight instruments, shall be equipped with two independent altitude measuring and display systems.

OPS 2A.455 Emergency Power Supply for Electrically Operated Attitude Indicating Instruments

- (a) Aeroplanes of a maximum certificated take-off mass of over 5700 kg newly introduced into service after 01 January 1975 shall be fitted with an emergency power supply, independent of the main electrical generating system, for the purpose of operating and illuminating, for a minimum period of 30 minutes, an attitude indicating instrument (artificial horizon), clearly visible to the pilot-in-command. The emergency power supply shall be automatically operative after the total failure of the main electrical generating system and clear indication shall be given on the instrument panel that the attitude indicator(s) is being operated by emergency power.



Note: Aeroplane with advanced cockpit automation systems (glass cockpits) should have system redundancy that provides the flight crew with attitude, heading, airspeed and altitude indications in case of failure of the primary system or display.

- (b) Instruments that are used by any one pilot shall be so arranged as to permit the pilot to see their indications readily from his or her station, with the minimum practicable deviation from the position and line of vision normally assumed when looking forward along the flight path.

OPS 2A.460 Weather-detecting Equipment

Pressurised aeroplanes when carrying passengers shall be equipped with operative weather-detecting equipment capable of detecting thunderstorms whenever such aeroplanes are being operated in areas where such conditions may be expected to exist along the route either at night or under instrument meteorological conditions.

OPS 2A.465 Operations above 15000 m (49000 ft) - Radiation Indicator

Aeroplanes intended to be primarily operated above 15000 m (49000 ft) should carry equipment to measure and indicate continuously the dose rate of total cosmic radiation being received (i.e. the total of ionizing and neutron radiation of galactic and solar origin) and the cumulative dose on each flight. The display unit of the equipment shall be readily visible to a flight crew member.

OPS 2A.470 Passenger and Cabin Crew Seats

- (a) Aeroplanes for which the individual certificate of airworthiness is first issued on or after 01 January 1981 shall be equipped with a forward or rearward facing seat (within 15 degrees of the longitudinal axis of the aeroplane), fitted with a safety harness for the use of each cabin crew member required to effect a safe and expeditious emergency evacuation.
- (b) Cabin crew seats provided shall be located near floor level and other emergency exits as required by the Authority, as the State of Registry, for emergency evacuation.

OPS 2A.475 Airborne Collision Avoidance System (ACAS)

All turbine-engined aeroplanes of a maximum certificated take-off mass in excess of 15000 kg or authorised to carry more than 30 passengers, for which the individual airworthiness certificate is first issued after 01 January 2007, shall be equipped with an airborne collision avoidance system (ACAS II) that meets traffic alert and collision avoidance system (TCAS) Version 7.1 as specified in RTCA/DO-185B or EUROCAE/ED-143.

OPS 2A.480 Pressure-altitude Reporting Transponder

Aeroplanes shall be equipped with a pressure-altitude reporting transponder which operates in accordance with the relevant provisions of ICAO Annex 10, Volume IV.

OPS 2A.485 Microphones

All flight crew members required to be on flight deck duty shall communicate through boom or throat microphones below the transition level/altitude.

OPS 2A.490 Ground Proximity Warning Systems (GPWS)

In addition to OPS 2A.422(b) and (c);



- (a) All turbine-engined aeroplanes of a maximum certificated take-off mass in excess of 5700 kg shall be equipped with a ground proximity warning system which has a forward-looking terrain avoidance function.
- (b) A ground proximity warning system installed in turbine-engined aeroplanes of a maximum certificated take-off mass in excess of 5700 kg for which the individual certificate of airworthiness was first issued after 01 January 2011 shall provide, as a minimum, warnings of at least the following circumstances;
- (1) excessive descent rate;
 - (2) excessive terrain closure rate;
 - (3) excessive altitude loss after take-off or go-around;
 - (4) unsafe terrain clearance while not in landing configuration;
 - (i) gear not locked down;
 - (ii) flaps not in a landing position; and
 - (5) excessive descent below the instrument glide path.

**Appendix 1 to OPS 2A.420****Cockpit Voice Recorder (CVR) and Cockpit Audio Recording System (CARS)**

(a) Start and stop logic

The CVR or CARS shall start to record prior to the aeroplane moving under its own power and record continuously until the termination of the flight when the aeroplane is no longer capable of moving under its own power. In addition, depending on the availability of electrical power, the CVR or CARS shall start to record as early as possible during the cockpit checks prior to engine start at the beginning of the flight until the cockpit checks immediately following engine shutdown at the end of the flight.

(b) Signals to be recorded

(1) The CVR shall record simultaneously on four separate channels, or more, at least the following:

- (i) voice communication transmitted from or received in the aeroplane by radio;
- (ii) aural environment on the flight deck;
- (iii) voice communication of flight crew members on the flight deck using the aeroplane's interphone system, if installed;
- (iv) voice or audio signals identifying navigation or approach aids introduced in the headset or speaker;
- (v) digital communications with ATS, unless recorded by the FDR; and

(c) The preferred CVR audio allocation should be as follows:

- (1) pilot-in-command audio panel;
- (2) co-pilot audio panel;
- (3) additional flight crew positions and time reference; and
- (4) cockpit area microphone.

(d) The CARS shall record simultaneously on two separate channels, or more, at least the following:

- (1) voice communication transmitted from or received in the aeroplane by radio;
- (2) aural environment on the flight deck; and
- (3) voice communication of flight crew members on the flight deck using the aeroplane's interphone system, if installed.

(e) The preferred CARS audio allocation should be as follows:

- (1) voice communication; and
- (2) aural environment on the flight deck.



Appendix 1 to OPS 2A.420 to OPS 2A.430 Inclusive Flight Recorders – General

Note 1: The following applies to all crash protected flight recorders which comprise one or more of the following:

- (1) *a flight data recorder (FDR),*
- (2) *a cockpit voice recorder (CVR)*
- (3) *an airborne image recorder (AIR),*
- (4) *a data link recorder (DLR).*

When image or data link information is required to be recorded on a crash-protected flight recorder, it is permissible to record it on either the CVR or the FDR.

Note 2: The following applies to all lightweight flight recorders which comprise one or more of the following:

- (1) *an aircraft data recording system (ADRS),*
- (2) *a cockpit audio recording system (CARS),*
- (3) *an airborne image recording system (AIRS)*
- (4) *a data link recording system (DLRS).*

When image or data link information is required to be recorded on a lightweight flight recorder, it is permissible to record it on either the CARS or the ADRS.

- (a) Non-deployable flight recorder containers shall be painted a distinctive orange colour;
- (b) Non-deployable crash protected flight recorder containers shall;
 - (1) carry reflective material to facilitate their location; and
 - (2) have a device to assist in locating that recorder in water and have securely attached an automatically activated underwater locating device operating at a frequency of 37.5 kHz that operates for a minimum of 90 days.
- (c) Automatic deployable flight recorder containers shall:
 - (1) be painted a distinctive orange colour; however the surface visible from outside the aeroplane may be of another colour;
 - (2) carry reflective material to facilitate their location; and
 - (3) have an integrated automatically activated ELT.
- (d) The flight recorder systems shall be installed so that:
 - (1) the probability of damage to the recordings is minimised;



- (2) there is an aural or visual means for pre-flight checking that the flight recorder systems are operating properly; and
- (3) if the flight recorder systems have an erasure device, the installation shall be designed to prevent operation of the device during flight time or crash impact; and
- (4) an aeroplane for which the individual certificate of airworthiness is first issued on or after 01 January 2023, a flight crew-operated erase function shall be provided on the flight deck which, when activated, modifies the recording of a CVR and AIR so that it cannot be retrieved using normal replay or copying techniques. The installation shall be designed to prevent activation during flight. In addition, the probability of an inadvertent activation of an erase function during an accident shall also be minimised.

Note: The erase function is intended to prevent access to CVR and AIR recordings by normal replay or copying means, but would not prevent accident investigation authorities access to such recordings by specialised replay or copying techniques.

- (e) The crash-protected flight recorder shall be installed so that they receive electrical power from a bus that provides the maximum reliability for operation of the flight recorder systems without jeopardising service to essential or emergency loads.
- (f) The lightweight flight recorders shall be connected to a power source having the characteristics which ensure proper and reliable recording in the operational environment.
- (g) The flight recorder systems, when tested by methods approved by the appropriate certifying authority, shall be demonstrated to be suitable for the environmental extremes over which they are designed to operate.
- (h) Means shall be provided for an accurate time correlation between the flight recorder systems recordings.
- (i) The flight recorder system manufacturer shall provide the appropriate certifying authority with the following information in respect of the flight recorder systems:
 - (1) manufacturer's operating instructions, equipment limitations and installation procedures;
 - (2) parameter origin or source and equations which relate counts to units of measurement;
 - (3) manufacturer's test reports; and
 - (4) detailed information to ensure the continued serviceability of the flight recorder system.
- (j) The holder of the airworthiness approval for the installation design of the flight recorder system shall make available the relevant continuing airworthiness information to the operator of the aeroplane to be incorporated in the continuing airworthiness maintenance programme. This continuing airworthiness information shall cover in detail all the tasks required to ensure the continued serviceability of the flight recorder system.

Note: The flight recorder system is composed of the flight recorder as well as any dedicated sensors, hardware and software that provide information required under this Appendix.



Appendix 2 to OPS 2.420 to OPS 2A.430 Inclusive Inspection of Flight Recorder Systems

- (a) Prior to the first flight of the day, the built-in test features for the flight recorders and flight data acquisition unit (FDAU), when installed, shall be monitored by manual and/or automatic checks.
- (b) FDR systems or ADRS, CVR systems or CARS, and AIR systems or AIRS shall have recording inspection intervals of one year. This period may be extended by the Authority to two years provided these systems have demonstrated a high integrity of serviceability and self-monitoring.
- (c) DLR systems or DLRS shall have recording inspection intervals of two years. This period may be extended by the Authority to four years provided these systems have demonstrated a high integrity of serviceability and self-monitoring.
- (d) Recording inspections shall be carried out as follows:
 - (1) an analysis of the recorded data from the flight recorders shall ensure that the recorder operates correctly for the nominal duration of the recording;
 - (2) the FDR or ADRS recording from a complete flight shall be examined in engineering units to evaluate the validity of all recorded parameters. Particular attention shall be given to parameters from sensors dedicated to the FDR or ADRS. Parameters taken from the aeroplane's electrical bus system need not be checked if their serviceability can be detected by other aeroplane systems;
 - (3) the readout facility shall have the necessary software to accurately convert the recorded values to engineering units and to determine the status of discrete signals;
 - (4) an annual examination of the recorded signal on the CVR or CARS shall be carried out by replay of the CVR or CARS recording. While installed in the aeroplane, the CVR or CARS shall record test signals from each aeroplane source and from relevant external sources to ensure that all required signals meet intelligibility standards;
 - (5) where practicable, during the examination, a sample of in-flight recordings of the CVR or CARS shall be examined for evidence that the intelligibility of the signal is acceptable; and
 - (6) an examination of the recorded images on the AIR or AIRS shall be carried out by replay of the AIR or AIRS recording. While installed in the aeroplane, the AIR or AIRS shall record test images from each aeroplane source and from relevant external sources to ensure that all required images meet recording quality standards.
 - (7) an examination of the recorded messages on the DLR or DLRS shall be carried out by replay of the DLR or DLRS recording.
- (e) A flight recorder system shall be considered unserviceable if there is a significant period of poor quality data, unintelligible signals, or if one or more of the mandatory parameters is not recorded correctly.
- (f) A report of the recording inspection shall be made available on request to regulatory authorities for monitoring purposes.



- (g) Calibration of the FDR system:
- (1) for those parameters which have sensors dedicated only to the FDR and are not checked by other means, recalibration shall be carried at an interval determined by the continuing airworthiness information for the FDR system. In the absence of such information, a recalibration shall be carried out at least every five years. The recalibration shall determine any discrepancies in the engineering conversion routines for the mandatory parameters and to ensure that parameters are being recorded within the calibration tolerances; and
 - (2) when the parameters of altitude and airspeed are provided by sensors that are dedicated to the FDR system, there shall be a recalibration performed at an interval determined by the continuing airworthiness information for the FDR system. In the absence of such information, a recalibration shall be carried out at least every two years.

**Appendix 1 to OPS 2A.425****Flight Data Recorder (FDR) and Aircraft data recording systems (ADRS)**

(See OPS 2A.425)

(a) Start and Stop Logic

The FDR or ADRS shall start to record prior to the aeroplane moving under its own power and record continuously until the termination of the flight when the aeroplane is no longer capable of moving under its own power.

(b) Parameters to be Recorded

(1) The parameters that satisfy the requirements for FDRs are listed in the paragraphs below in Appendix 1 to OPS 2A.425. The number of parameters to be recorded shall depend on aeroplane complexity. The parameters without an asterisk (*) are mandatory parameters which shall be recorded regardless of aeroplane complexity. In addition, the parameters designated by an asterisk (*) shall be recorded if an information data source for the parameter is used by aeroplane systems or the flight crew to operate the aeroplane. However, other parameters may be substituted with due regard to the aeroplane type and the characteristics of the recording equipment.

(2) If further FDR recording capacity is available, recording of the following additional information shall be considered:

(i) operational information from electronic display systems, such as electronic flight instrument systems (EFIS), electronic centralized aeroplane monitor (ECAM) and engine indication and crew alerting system (EICAS). Use the following order of priority:

- (A) parameters selected by the flight crew relating to the desired flight path, e.g. barometric pressure setting, selected altitude, selected airspeed, decision height, and autoflight system engagement and mode indications if not recorded from another source;
- (B) display system selection/status, e.g. SECTOR, PLAN, ROSE, NAV, WXR, COMPOSITE, COPY, ETC.;
- (C) warnings and alerts; and
- (D) the identity of displayed pages for emergency procedures and checklists; and
- (E) additional engine parameters (EPR, N_1 , fuel flow etc.)

(ii) retardation information including brake application for use in the investigation of landing overruns and rejected take-offs.

(3) The parameters that satisfy the requirements for flight path and speed as displayed to the pilot(s) are listed below. The parameters without an (*) are mandatory parameters which shall be recorded. In addition, the parameters designated by an (*) shall be recorded if an information source for the parameter is displayed to the pilot and is practicable to record:

— Pressure altitude



- Indicated airspeed or calibrated airspeed
- Heading (primary flight crew reference)
- Pitch attitude
- Roll attitude
- Engine thrust/power
- Landing-gear status*
- Total or outside air temperature*
- Time*
- Navigation data*: drift angle, wind speed, wind direction, latitude/longitude
- Radio altitude*

- (4) The parameters that satisfy the requirements for ADRS are the first 7 parameters listed in Appendix 2 to OPS 2A.425.
- (5) If further ADRS recording capacity is available, the recording of any parameters from 8 onwards defined in Appendix 2 to OPS 2A.425 shall be considered.

(c) Additional Information

- (1) The measurement range, recording interval and accuracy of parameters on installed equipment shall be verified by methods approved by the appropriate certificating authority.
- (2) Documentation concerning parameter allocation, conversion equations, periodic calibration and other serviceability/maintenance information shall be maintained by the operator/owner. The documentation needs to be sufficient to ensure that accident investigation authorities have the necessary information to read out the data in engineering units.

**Appendix 2 to OPS 2A.425****Airborne Image Recorder (AIR) and Airborne Image Recording System (AIRS)**

(a) Start and Stop Logic

The AIR or AIRS shall start to record prior to aeroplane moving under its own power and record continuously until the termination of the flight when the aeroplane is no longer capable of moving under its own power. In addition, depending on the availability of electrical power, the AIR or AIRS shall start to record as early as possible during the cockpit checks prior to engine start at the beginning of the flight until the cockpit checks immediately following engine shutdown at the end of the flight.

(b) Classes

- (1) A Class A AIR or AIRS captures the general cockpit area in order to provide data supplemental to conventional flight recorders.

Note 1: To respect crew privacy, the cockpit area view may be designed as far as practical to exclude the head and shoulders of crew members whilst seated in their normal operating position.

Note 2: There are no provisions for Class A AIR or AIRS in this document.

- (2) A Class B AIR or AIRS captures data link message displays.
- (3) A Class C AIR or AIRS captures instruments and control panels.

Note: A Class C AIR or AIRS may be considered as a means for recording flight data where it is not practical or is prohibitively expensive to record on an FDR or an ADRS, or where an FDR is not required.



Appendix 1 to OPS 2A.430

Data Link Recorder (DLR) Applications to be Recorded

- (a) Where the aeroplane flight path is authorised or controlled through the use of data link messages, all data link messages, both uplinks (to the aeroplane) and downlinks (from the aeroplane), shall be recorded on the aeroplane. As far as practicable, the time the messages were displayed to the flight crew and the time of the responses shall be recorded.

Note: Sufficient information to derive the content of the data link communications message and the time the messages were displayed to the flight crew is needed to determine an accurate sequence of events on board the aeroplane.

- (b) Messages applying to the applications listed below shall be recorded. Applications without the asterisk (*) are mandatory applications which shall be recorded regardless of the system complexity. Applications with an (*) shall be recorded only as far as is practicable given the architecture of the system.

Item No.	Application type	Application description	Recording content
1	Data link initiation	This includes any applications used to log on to or initiate data link service. In FANS-1/A and ATN, these are ATS facilities notification (AFN) and context management (CM) respectively.	C
2	Controller/pilot communication	This includes any application used to exchange requests, clearances, instructions and reports between the flight crew and controllers on the ground. In FANS-1/A and ATN, this includes the CPDLC application. It also includes applications used for the exchange of oceanic (OCL) and departure clearances (DCL) as well as data link delivery of taxi clearances.	C
3	Addressed surveillance	This includes any surveillance application in which the ground sets up contracts for delivery of surveillance data. In FANS-1/A and ATN, this includes the automatic dependent surveillance — contract (ADS-C) application. Where parametric data are reported within the message they shall be recorded unless data from the same source are recorded on the FDR.	C
4	Flight information	This includes any service used for delivery of flight information to specific aircraft. This includes, for example, data link aviation weather report service (D-METAR), data link-automatic terminal service (D-ATIS), digital Notice to Airmen (D-NOTAM) and other textual data link services.	C
5	Aircraft broadcast surveillance	This includes elementary and enhanced surveillance systems, as well as automatic dependent surveillance — broadcast (ADS-B) output data. Where parametric data sent by the aeroplane are reported within the message they shall be recorded unless data from the same source are recorded on the FDR.	M*
6	Aeronautical operational control data	This includes any application transmitting or receiving data used for aeronautical operational control purposes (per the ICAO definition of operational control).	M*

Key:

C: Complete contents recorded.

M: Information that enables correlation to any associated records stored separately from the aeroplane.

*: Applications to be recorded only as far as is practicable given the architecture of the system.



Appendix 1 to OPS 2A.425 Parameter Characteristics for Flight Data Recorders

Serial number	Parameter	Applicability	Measurement range	Maximum sampling and recording interval (seconds)	Accuracy limits (sensor input compared to FDR readout)	Recording resolution
1	Time (UTC when available, otherwise relative time count or GNSS time sync)		24 hours	4	$\pm 0.125\%/h$	1 s
2	Pressure altitude		-300 m (-1 000 ft) to maximum certificated altitude of aircraft +1 300 m (+1 000 ft)	1	± 30 m to ± 200 m (± 100 ft to ± 700 ft)	1.5 m (5 ft)
3	Indicated airspeed or calibrated airspeed		95 km/h (50 kt) to max V_{Lo} (Note 1) V_{Lo} to $1.2 V_{Lo}$ (Note 2)	1	$\pm 5\%$ $\pm 3\%$	1 kt (0.5 kt recommended)
4	Heading (primary flight crew reference)		360°	1	$\pm 2^\circ$	0.5°
5	Normal acceleration		-3 g to +6 g	0.125	$\pm 1\%$ of maximum range excluding datum error of $\pm 5\%$	0.004 g
6	Pitch attitude		$\pm 75^\circ$ or usable range whichever is greater	0.25	$\pm 2^\circ$	0.5°
7	Roll attitude		$\pm 180^\circ$	0.25	$\pm 2^\circ$	0.5°
8	Radio transmission keying		On-off (one discrete)	1		
9	Power on each engine (Note 3)		Full range	1 (per engine)	$\pm 3\%$	0.2% of full range or the resolution required to operate the aircraft
10*	Trailing edge flap and cockpit control selection		Full range or each discrete position	2	$\pm 5\%$ or as pilot's indicator	0.5% of full range or the resolution required to operate the aircraft



Serial number	Parameter	Applicability	Measurement range	Maximum sampling and recording interval (seconds)	Accuracy limits (sensor input compared to FDR readout)	Recording resolution
11*	Leading edge flap and cockpit control selection		Full range or each discrete position	2	±5% or as pilot's indicator	0.5% of full range or the resolution required to operate the aircraft
12*	Thrust reverser position		Stowed, in transit, and reverse	1 (per engine)		
13*	Ground spoiler/speed brake selection (selection and position)		Full range or each discrete position	1	±2% unless higher accuracy uniquely required	0.2% of full range
14	Outside air temperature		Sensor range	2	±2°C	0.3°C
15*	Autopilot/auto throttle/AFCs mode and engagement status		A suitable combination of discrete	1		
16	Longitudinal acceleration		±1 g	0.25	±0.015 g excluding a datum error of ±0.05 g	0.004 g
17	Lateral acceleration (Note 3)		±1 g	0.25	±0.015 g excluding a datum error of ±0.05 g	0.004 g
18	Pilot input and/or control surface position—primary controls (pitch, roll, yaw) (Notes 4 and 8)	Application for type certification submitted to a Contracting State before 1 January 2016	Full range	0.25	±2° unless higher accuracy uniquely required	0.2% of full range or as installed
		Application for type certification submitted to a Contracting State on or after 1 January 2016	Full range	0.125	±2° unless higher accuracy uniquely required	0.2% of full range or as installed
19	Pitch trim position		Full range	1	±3% unless higher accuracy uniquely required	0.3% of full range or as installed
20*	Radio altitude		−6 m to 750 m (−20 ft to 2 500 ft)	1	±0.6 m (±2 ft) or ±3% whichever is greater below 150 m (500 ft) and ±5% above 150 m (500 ft)	0.3 m (1 ft) below 150 m (500 ft) 0.3 m (1 ft) + 0.5% of full range above 150 m (500 ft)



Serial number	Parameter	Applicability	Measurement range	Maximum sampling and recording interval (seconds)	Accuracy limits (sensor input compared to FDR readout)	Recording resolution
21*	Vertical beam deviation (ILS/GNSS/GLS glide path MLS elevation, IRNAV/IAN vertical deviation)		Signal range	1	±3%	0.3% of full range
22*	Horizontal beam deviation (ILS/GNSS/GLS localizer, MLS azimuth, IRNAV/IAN lateral deviation)		Signal range	1	±3%	0.3% of full range
23	Marker beacon passage		Discrete	1		
24	Master warning		Discrete	1		
25	Each NAV receiver frequency selection (Note 5)		Full range	4	As installed	
26*	DME 1 and 2 distance (includes distance to runway threshold (GLS) and distance to missed approach point (IRNAV/IAN) (Notes 5 and 6))		0–370 km (0–200 NM)	4	As installed	1 852 m (1 NM)
27	Air/ground status		Discrete	1		
28*	GPWS/TAWS/GCAS status (selection of terrain display mode including pop-up display status) and (terrain alerts, both cautions and warnings, and advisories) and (on/off switch position)		Discrete	1		
29*	Angle of attack		Full range	0.5	As installed	0.3% of full range
30*	Hydraulics, each system (low pressure)		Discrete	2		0.5% of full range



Serial number	Parameter	Applicability	Measurement range	Maximum sampling and recording interval (seconds)	Accuracy limits (sensor input compared to FDR readout)	Recording resolution
31*	Navigation data (latitude/longitude, ground speed and drift angle) (Note 7)		As installed	1	As installed	
32*	Landing gear and gear selector position		Discrete	4	As installed	
33*	Groundspeed		As installed	1	Data should be obtained from the most accurate system	1 kt
34	Brakes (left and right brake pressure, left and right brake pedal position)		(Maximum metered brake range, discrete or full range)	1	±3%	2% of full range
35*	Additional engine parameters (EPR, N_{1s} , indicated vibration level, N_{1s} , EGT, fuel flow, fuel cut-off lever position, N_1 , engine fuel metering valve position)	Engine fuel metering valve position: Application for type certification is submitted to a Contracting State on or after 1 January 2023	As installed	Each engine each second	As installed	2% of full range
36*	TCAS/ACAS (traffic alert and collision avoidance system)		Discrete(s)	1	As installed	
37*	Wind shear warning		Discrete	1	As installed	
38*	Selected barometric setting (pilot, co-pilot)		As installed	64	As installed	0.1 mb (0.01 in-Hg)
39*	Selected altitude (all pilot selectable modes of operation)		As installed	1	As installed	Sufficient to determine crew selection
40*	Selected speed (all pilot selectable modes of operation)		As installed	1	As installed	Sufficient to determine crew selection
41*	Selected Mach (all pilot selectable modes of operation)		As installed	1	As installed	Sufficient to determine crew selection
42*	Selected vertical speed (all pilot selectable modes of operation)		As installed	1	As installed	Sufficient to determine crew selection
43*	Selected heading (all pilot selectable modes of operation)		As installed	1	As installed	Sufficient to determine crew selection



Serial number	Parameter	Applicability	Measurement range	Maximum sampling and recording interval (seconds)	Accuracy limits (sensor input compared to FDR readout)	Recording resolution
44*	Selected flight path (all pilot selectable modes of operation) (course/DSTRK, path angle, final approach path (RNAV/LAN))			1	As installed	As installed
45*	Selected decision height		As installed	64	As installed	Sufficient to determine crew selection
46*	EFIS display format (pilot, co-pilot)		Discrete(s)	4	As installed	
47*	Multi-function/engine/alerts display format		Discrete(s)	4	As installed	
48*	AC electrical bus status		Discrete(s)	4	As installed	
49*	DC electrical bus status		Discrete(s)	4	As installed	
50*	Engine bleed valve position		Discrete(s)	4	As installed	
51*	APU bleed valve position		Discrete(s)	4	As installed	
52*	Computer failure		Discrete(s)	4	As installed	
53*	Engine thrust command		As installed	2	As installed	2% of full range
54*	Engine thrust target		As installed	4	As installed	2% of full range
55*	Computed centre of gravity		As installed	64	As installed	1% of full range
56*	Fuel quantity in CG trim tank		As installed	64	As installed	1% of full range
57*	Head-up display in use		As installed	4	As installed	
58*	Para-visual display on/off		As installed	1	As installed	
59*	Operational stall protection, stick shaker and pusher activation		As installed	1	As installed	
60*	Primary navigation system reference (GNSS, DME, VOR/DME, MLS, Loran C, localizer glide slope)		As installed	4	As installed	
61*	Ice detection		As installed	4	As installed	



Serial number	Parameter	Applicability	Measurement range	Maximum sampling and recording interval (seconds)	Accuracy limits (sensor input compared to FDR readout)	Recording resolution
62*	Engine warning each engine vibration		As installed	1	As installed	
63*	Engine warning each engine over temperature		As installed	1	As installed	
64*	Engine warning each engine oil pressure low		As installed	1	As installed	
65*	Engine warning each engine over speed		As installed	1	As installed	
66*	Yaw trim surface position		Full range	2	±3% unless higher accuracy uniquely required	0.3% of full range
67*	Roll trim surface position		Full range	2	±3% unless higher accuracy uniquely required	0.3% of full range
68*	Yaw or sideslip angle		Full range	1	±5%	0.5°
69*	De-icing and/or anti-icing systems selection		Discrete(s)	4		
70*	Hydraulic pressure (each system)		Full range	2	±5%	100 psi
71*	Loss of cabin pressure		Discrete	1		
72*	Cockpit trim control input position, Pitch		Full range	1	±5%	0.2% of full range or as installed
73*	Cockpit trim control input position, Roll		Full range	1	±5%	0.2% of full range or as installed
74*	Cockpit trim control input position, Yaw		Full range	1	±5%	0.2% of full range or as installed
75	All cockpit flight control input forces (control wheel, control column, rudder pedal)		Full range (±311 N (±70 lbf), ±378 N (±85 lbf), ±734 N (±165 lbf))	1	±5%	0.2% of full range or as installed
76*	Event marker		Discrete	1		
77*	Date		365 days	64		
78*	Actual navigation performance or estimated position error or estimated position uncertainty		As installed	4	As installed	



Serial number	Parameter	Applicability	Measurement range	Maximum sampling and recording interval (seconds)	Accuracy limits (sensor input compared to FDR readout)	Recording resolution
79*	Cabin pressure altitude	Application for type certification submitted to a Contracting State on or after 1 January 2023	As installed (0 ft to 40 000 ft recommended)	1	As installed	100 ft
80*	Aeroplane computed weight	Application for type certification submitted to a Contracting State on or after 1 January 2023	As installed	64	As installed	1% of full range
81*	Flight director command (left flight director pitch command, left flight director roll command, right flight director pitch command, right flight director roll command)	Application for type certification submitted to a Contracting State on or after 1 January 2023	Full range	1	± 2°	0.5°
82*	Vertical speed	Application for type certification submitted to a Contracting State on or after 1 January 2023	As installed	0.25	As installed (32 ft/min recommended)	16 ft/min

Notes.—

1. V_{K} stalling speed or minimum steady flight speed in the landing configuration is in Section "Abbreviations and Symbols".
2. V_D design diving speed.
3. Record sufficient inputs to determine power.
4. For aeroplanes with control systems in which movement of a control surface will back drive the pilot's control, "or" applies. For aeroplanes with control systems in which movement of a control surface will not back drive the pilot's control, "and" applies. In aeroplanes with split surfaces, a suitable combination of inputs is acceptable in lieu of recording each surface separately. In aeroplanes with independent pilot input on primary controls, each pilot input on primary controls needs to be recorded separately.
5. If signal available in digital form.
6. Recording of latitude and longitude from INS or other navigation system is a preferred alternative.
7. If signals readily available.
8. It is not intended that aeroplanes issued with an individual certificate of airworthiness before 1 January 2016 be modified to meet the measurement range, maximum sampling and recording intervals, accuracy limits or recording resolution guidance description detailed in this Appendix.



Appendix 2 to OPS 2A.425

Parameter Characteristics for Aircraft Data Recording Systems (ADRS)

No.	Parameter name	Minimum recording range	Maximum recording interval in seconds	Minimum recording accuracy	Minimum recording resolution	Remarks
1	Heading:					
1	a) Heading (Magnetic or True)	$\pm 180^\circ$	1	$\pm 2^\circ$	0.5°	* Heading is preferred, if not available, yaw rate shall be recorded
	b) Yaw rate	$\pm 300^\circ/\text{s}$	0.25	$\pm 1\% + \text{drift of } 360^\circ/\text{h}$	$2^\circ/\text{s}$	
2	Pitch:					
	a) Pitch attitude	$\pm 90^\circ$	0.25	$\pm 2^\circ$	0.5°	* Pitch attitude is preferred, if not available, pitch rate shall be recorded
	b) Pitch rate	$300^\circ/\text{s}$	0.25	$\pm 1\% + \text{drift of } 360^\circ/\text{h}$	$2^\circ/\text{s}$	
3	Roll:					
	a) Roll attitude	$\pm 180^\circ$	0.25	$\pm 2^\circ$	0.5°	* If not available, roll rate shall be recorded
	b) Roll rate	$300^\circ/\text{s}$	0.25	$\pm 1\% + \text{drift of } 360^\circ/\text{h}$	$2^\circ/\text{s}$	
4	Positioning system:					
	a) Time	24 hours	1	$\pm 0.5 \text{ s}$	0.1 s	UTC time preferred where available
	b) Latitude/longitude	Latitude: $\pm 90^\circ$ Longitude: $\pm 180^\circ$	2 (1 if available)	As installed (0.00015° recommended)	0.00005°	
	c) Altitude	$-300 \text{ m } (-1\,000 \text{ ft})$ to maximum certified altitude of aircraft + $1\,500 \text{ m } (5\,000 \text{ ft})$	2 (1 if available)	As installed ($\pm 15 \text{ m } (\pm 50 \text{ ft})$ recommended)	$1.5 \text{ m } (5 \text{ ft})$	
	d) Ground speed	$0-1\,000 \text{ kt}$	2 (1 if available)	As installed ($\pm 5 \text{ kt}$ recommended)	1 kt	



No.	Parameter name	Minimum recording range	Maximum recording interval in seconds	Minimum recording accuracy	Minimum recording resolution	Remarks
	e) Track	0-360°	2 (1 if available)	As installed (±2° recommended)	0.5°	
	f) Estimated error	Available range	2 (1 if available)	As installed	As installed	Shall be recorded if readily available
5	Normal acceleration	-3 g to +6 g (*)	0.25 (0.125 if available)	As installed (±0.09 g excluding a datum error of ±0.45 g recommended)	0.004 g	
6	Longitudinal acceleration	±1 g (*)	0.25 (0.125 if available)	As installed (±0.015 g excluding a datum error of ±0.05 g recommended)	0.004 g	
7	Lateral acceleration	±1 g (*)	0.25 (0.125 if available)	As installed (±0.015 g excluding a datum error of ±0.05 g recommended)	0.004 g	
8	External static pressure (or pressure altitude)	34.4 mb (3.44 in-Hg) to 310.2 mb (31.02 in-Hg) or available sensor range	1	As installed (±1 mb (0.1 in-Hg) or ±30 m (±100 ft) to ±210 m (±700 ft) recommended)	0.1 mb (0.01 in-Hg) or 1.5 m (5 ft)	
9	Outside air temperature (or total air temperature)	-50° to +90°C or available sensor range	2	As installed (±2°C recommended)	1°C	
10	Indicated air speed	As the installed pilot display measuring system or available sensor range	1	As installed (±3% recommended)	1 kt (0.5 kt recommended)	
11	Engine RPM	Full range including overspeed condition	Each engine each second	As installed	0.2% of full range	
12	Engine oil pressure	Full range	Each engine each second	As installed (5% of full range recommended)	2% of full range	



No.	Parameter name	Minimum recording range	Maximum recording interval in seconds	Minimum recording accuracy	Minimum recording resolution	Remarks
13	Engine oil temperature	Full range	Each engine each second	As installed (5% of full range recommended)	2% of full range	
14	Fuel flow or pressure	Full range	Each engine each second	As installed	2% of full range	
15	Manifold pressure	Full range	Each engine each second	As installed	0.2% of full range	
16	Engine thrust/power/torque parameters required to determine propulsive thrust/power*	Full range	Each engine each second	As installed	0.1% of full range	* Sufficient parameters e.g. EPR/N ₁ or torque/N _p as appropriate to the particular engine shall be recorded to determine power in both normal and reverse thrust. A margin for possible overspeed should be provided.
17	Engine gas generator speed (N _g)	0–150%	Each engine each second	As installed	0.2% of full range	
18	Free power turbine speed (N _f)	0–150%	Each engine each second	As installed	0.2% of full range	
19	Coolant temperature	Full range	1	As installed (±5°C recommended)	1°C	
20	Main voltage	Full range	Each engine each second	As installed	1 Volt	
21	Cylinder head temperature	Full range	Each cylinder each second	As installed	2% of full range	
22	Flaps position	Full range or each discrete position	2	As installed	0.5°	
23	Primary flight control surface position	Full range	0.25	As installed	0.2% of full range	
24	Fuel quantity	Full range	4	As installed	1% of full range	
25	Exhaust gas temperature	Full range	Each engine each second	As installed	2% of full range	
26	Emergency voltage	Full range	Each engine each second	As installed	1 Volt	
27	Trim surface position	Full range or each discrete position	1	As installed	0.3% of full range	
28	Landing gear position	Each discrete position*	Each gear every two seconds	As installed		* Where available, record up-and-locked and down-and-locked position
29	Novel/unique aircraft features	As required	As required	As required	As required	



This Page Intentionally Left Blank

**SUBPART F****COMMUNICATION AND NAVIGATION EQUIPMENT****OPS 2A.510 Communication equipment**

In addition to the requirements OPS 2A.501, an aeroplane shall be provided with radio communication equipment capable of:

- (a) conducting two-way communication for aerodrome control purposes;
- (b) receiving meteorological information at any time during flight; and
- (c) conducting two-way communication at any time during flight with at least one aeronautical station and with such other aeronautical stations and on such frequencies as may be prescribed by the appropriate authority.

Note: These requirements are considered fulfilled if the ability to conduct the communications specified therein is established during radio propagation conditions which are normal for the route.

OPS 2A.520 Installation

The equipment installation shall be such that the failure of any single unit required for either communications, navigation or surveillance purposes or both will not result in the failure of another unit required for communications, navigation or surveillance purposes.

OPS 2A.530 Electronic Navigation Data Management

- (a) The operator of an aeroplane shall not employ electronic navigation data products that have been processed for application in the air and on the ground unless the State of Registry has approved the operator's procedures for ensuring that the process applied and the products delivered have met acceptable standards of integrity and that the products are compatible with the intended function of the equipment that will use them. The State of Registry shall ensure that the operator continues to monitor both process and products.
- (b) The operator shall implement procedures that ensure the timely distribution and insertion of current and unaltered electronic navigation data to all aeroplanes that require it.



This Page Intentionally Left Blank

**SUBPART G****MAINTENANCE****OPS 2A.610 Operator's Maintenance Responsibilities**

The operator shall comply with the requirements of OPS 2A.601.

OPS 2A.630 Maintenance Programme

- (a) The operator shall provide, for the use and guidance of maintenance and operational personnel concerned, a maintenance programme, acceptable to the State of Registry, containing the information required by OPS 2A.820. The design and application of the operator's maintenance programme shall observe Human Factors principles according to the State of Registry's guidance material.
- (b) Copies of all amendments to the maintenance programme shall be furnished promptly to all organisations or persons to whom the maintenance programme has been issued.

OPS 2A.640 Continuing Airworthiness Information

The operator of an aeroplane of a maximum certificated take-off mass in excess of 5700 kg shall, as prescribed by the Authority, as the State of Registry, ensure that the information resulting from maintenance and operational experience with respect to continuing airworthiness, is transmitted to the organisation responsible for type design of that aeroplane.

OPS 2A.650 Maintenance Release

The operator shall comply with the requirements of OPS 2A.604.



This Page Intentionally Left Blank



SUBPART H

FLIGHT CREW

OPS 2A.710 Composition of the Flight Crew

- (a) For each flight the operator shall designate a pilot to act as pilot-in-command.
- (b) When a separate flight engineer's station is incorporated in the design of an aeroplane, the flight crew shall include at least one flight engineer especially assigned to that station, unless the duties associated with that station can be satisfactorily performed by another flight crew member, holding a flight engineer licence, without interference with regular duties.

OPS 2A.720 Flight Crew Member Emergency Duties

The operator shall, for each type of aeroplane, assign to all flight crew members the necessary functions they are to perform in an emergency or in a situation requiring emergency evacuation. Recurrent training in accomplishing these functions shall be contained in the operator's training programme and shall include instruction in the use of all emergency and life-saving equipment required to be carried, and drills in the emergency evacuation of the aeroplane.

OPS 2A.730 Flight Crew Member Training Programmes

- (a) The operator shall establish and maintain a training programme that is designed to ensure that a person who receives training acquires and maintains the competency to perform assigned duties, including skills related to human performance.
- (b) Ground and flight training programmes shall be established, either through internal programmes or through a training services provider, and shall include or make reference to a syllabus for those training programmes in the programme operations manual.
- (c) The training programme shall include training to competency for all equipment installed.

Note: Flight simulators should be used to the maximum extent practicable for initial and annual recurrent training.

OPS 2A.740 Qualifications

- (a) Flight crew member licensing

The operator shall:

- (1) ensure that each flight crew member assigned to duty holds a valid licence issued by the State of Registry, or if issued by another Contracting State, rendered valid by the State of Registry;
- (2) ensure that flight crew members are properly rated; and
- (3) be satisfied that flight crew members are competent to carry out assigned duties.



(b) Training

The operator of an aeroplane equipped with an airborne collision avoidance system (ACAS II) shall ensure that each flight crew member has been appropriately trained to competency in the use of ACAS II equipment and the avoidance of collisions.

(c) Recent experience

(1) Pilot-in-Command

[The operator shall not assign a pilot to act as pilot-in-command of an aeroplane carrying passengers unless that pilot has made at least three take-offs and landings within the preceding 90 days on the same type of aeroplane or in a flight simulator approved for the purpose.]

(2) Co-pilot

The operator shall not assign a co-pilot to operate at the flight controls of an aeroplane carrying passengers during take-off and landing unless that pilot has made at least three take-offs and landings within the preceding 90 days on the same type of aeroplane or in a flight simulator approved for the purpose.]

(d) Pilot proficiency checks

The operator shall ensure that piloting technique and the ability to execute emergency procedures is checked periodically in such a way as to demonstrate the pilot's competence. Where the operation may be conducted under the instrument flight rules, the operator shall ensure that the pilot's competence to comply with such rules is demonstrated to either a check pilot of the operator or a representative of the State issuing the pilot licence.

**SUBPART I****MANUALS, LOGS AND RECORDS****OPS 2A.820 Maintenance Programme**

- (a) A maintenance programme for each aeroplane shall contain the following information:
- (1) maintenance tasks and the intervals at which these are to be performed, taking into account the anticipated utilisation of the aeroplane;
 - (2) when applicable, a continuing structural integrity programme;
 - (3) procedures for changing or deviating from (a) and (b) above as approved by the State of Registry; and
 - (4) when applicable and approved by the State of Registry, condition monitoring and reliability programme descriptions for aeroplane systems, components and engines.
- (b) Maintenance tasks and intervals that have been specified as mandatory in approval of the type design, or approved changes to the maintenance programme, shall be identified as such.
- Note: The maintenance programme should be based on maintenance programme information made available by the State of Design or by the organisation responsible for the type design, and any additional applicable experience.*
- (c) The design and application of the operator's maintenance programme shall observe Human Factors principles according to the State of Registry's guidance material.

OPS 2A.830 Technical log

A Technical log for the aeroplane shall be provided in accordance with the requirements of CAR AIR , or CAR CAMO.540 where the continuing airworthiness management is contracted to a Authority approved CAR CAMO organisation.



This Page Intentionally Left Blank

**SUBPART J****SECURITY****OPS 2A.910 Security programme**

Note: General Aviation operators, operating under CAR OPS 2A, Part II, should establish, implement and maintain a written operator security programme that meets the requirements of the National Civil Aviation Security Programme of San Marino. This security programme may be incorporated in the programme operations manual.

OPS 2A.920 Flight Crew Compartment Security

In an aeroplane which is equipped with a flight crew compartment door, this door shall be capable of being locked, and means shall be provided by which the cabin crew can notify the flight crew in the event of suspicious activity or security breaches in the cabin.



This Page Intentionally Left Blank

**SUBPART K****CABIN CREW****OPS 2A.950 Assignment of Emergency Duties**

The requirement for cabin crew for each type of aeroplane shall be determined by the operator, based on seating capacity or the number of passengers carried, in order to effect a safe and expeditious evacuation of the aeroplane, and the necessary functions to be performed in an emergency or a situation requiring emergency evacuation. The operator shall assign these functions for each type of aeroplane.

OPS 2A.960 Cabin Crew at Emergency Evacuation Stations

When cabin crew are utilised by the operator, each cabin crew member assigned to emergency evacuation duties shall occupy a seat provided during take-off and landing and whenever the pilot-in-command so directs.

OPS 2A.970 Protection of Cabin Crew During Flight

Each cabin crew member shall be seated with seat belt or, when provided, safety harness fastened during take-off and landing and whenever the pilot-in-command so directs.

OPS 2A.980 Training

The operator shall ensure that a training programme is completed by all persons before being assigned as a cabin crew member.

Note: The operator should establish and maintain a cabin crew training programme that is designed to ensure that persons who receive training acquire the competency to perform their assigned duties and includes or makes reference to a syllabus for the training programme in the programme operations manual. The training programme should include Human Factors training.



This Page Intentionally Left Blank



PART III

FRACTIONAL OWNERSHIP PROGRAMME



This Page Intentionally Left Blank



SUBPART A

GENERAL

OPS 2A.1005 Applicability

- (a) CAR OPS 2A, Part III states additional requirements for large and turbojet aeroplanes and applies to operators specifically authorised to conduct fractional ownership programme operations.
- (b) Operators of aeroplanes under a fractional ownership programme shall also comply with the regulations contained in OPS 2A Part I and Part II.
- (c) A programme operator, once approved by the Authority for a fractional ownership programme for large and turbojet aeroplanes in accordance with OPS 2A, Part III, may be further authorised to add OPS 2A, Part I aeroplanes under the existing fractional ownership programme.

OPS 2A.1010 Accountable Manager

A programme operator of an aeroplane under a fractional ownership programme shall employ an Accountable Manager acceptable to the Authority, who is the responsible person for compliance with the management specifications of Subpart B and the standards required by OPS 2A.

OPS 2A.1015 Management contract between fractional owner and programme operator

The programme operator shall enter into a fractional ownership programme management arrangement with the fractional owners that;

- (a) requires the programme operator to ensure that the programme conforms to all applicable requirements of OPS 2A, Part III;
- (b) provides the fractional owner the right to inspect and to audit, or have a designee of the owner inspect and audit, the records of the programme operator pertaining to the operational safety of the programme and those records required to show compliance with the management specifications and all applicable regulations.

Note: These records include, but are not limited to, the management specifications, authorisations, approvals, manuals, log books, and maintenance records maintained by the programme operator.

- (c) designates the programme operator as the fractional owner's agent to receive service of notices pertaining to the programme that the Authority seeks to provide to owners and authorises the Authority to send such notices to the programme operator in its capacity as the agent of the owner for such service; and
- (d) acknowledges the Authority's right to contact the fractional owner directly if the Authority determines that direct contact is necessary.

OPS 2A.1020 Prohibitions and limitations

- (a) Except as provided in OPS 2A.010, no fractional owner may carry persons or property for remuneration or hire on a programme flight.



- (b) During the term of the multi-year programme agreements under which a fractional owner has obtained a minimum fractional ownership interest in a programme aircraft, the flight hours used during that term by the fractional owner on programme aircraft must not exceed the total hours associated with the fractional owner's share of ownership.
- (c) No person may sell an aircraft interest in a fractional ownership programme that is smaller than that prescribed in the definition of “minimum fractional ownership interest” under OPS 2A.1045 unless flights associated with that interest are operated under CAR OPS 1 and are conducted by a commercial air transport operator certificated under CAR OPS 1.

OPS 2A.1025 Flight conducted under CAR OPS 1

- (a) Except as provided in OPS 2A.010(a), when a non-programme aircraft is used to substitute for a programme flight, the flight must be operated in compliance with CAR OPS 1.
- (b) A programme operator who holds an air operator certificate under CAR OPS 1 may conduct a flight for the use of a fractional owner under CAR OPS 1 if the aircraft is listed on the operations specifications of the air operator certificate holder for CAR OPS 1.
- (c) the fractional owner must be informed when a flight is being conducted as a programme flight or is being conducted under CAR OPS 1.

OPS 2A.1030 Operational control responsibilities and delegation

- (a) The Accountable Manager, on behalf of the programme operator, shall be responsible for the operational control of a programme flight and is ultimately responsible for safe operations and for complying with all applicable requirements of CAR OPS 2A, including those related to airworthiness and operations in connection with the flight.
- (b) Upon the signing of an initial programme management services contract, or a renewal or extension of a programme management services contract, the Accountable Manager must brief the fractional owner on the Accountable Manager's operational control responsibilities, and each fractional owner must review and sign an acknowledgment of these operational control responsibilities.
- (c) Responsibility for operational control shall be delegated only to the commander of a programme aircraft by the Accountable Manager.
- (d) The management specifications and authorisations/approvals required by CAR OPS 2A, Subpart B are issued to the programme operator, with the Accountable Manager acting on behalf of the programme operator and fractional owners collectively.
- (e) The management specifications, authorisations, and approvals of sub-paragraph (d) will not be affected by any change in ownership of a programme aircraft, as long as the aircraft remains a programme aircraft in the identified programme.

OPS 2A.1035 Issuing or denying management specifications

- (a) A person applying for management specifications must submit an application;
 - (1) in a form and manner prescribed by the Authority; and
 - (2) containing any information the Authority requires the applicant to submit.



- (b) Management specifications will be issued to the programme operator on behalf of the fractional owners if, after investigation, the Authority finds that the applicant;
- (1) meets the applicable requirements of OPS 2A, Part III; and
 - (2) is properly and adequately equipped in accordance with the requirements of CAR OPS 2A and is able to conduct safe operations under appropriate provisions of OPS 2A, Part III and the management specifications.
- (c) An application for management specifications will be denied if the Authority finds that the applicant is not properly or adequately equipped or is not able to conduct safe operations.

OPS 2A.1040 Safety Management System

The safety management system established and maintained under OPS 2A.120 shall be made acceptable to the Authority.

OPS 2A.1045 Definitions

- (a) The following definitions apply to fractional ownership programmes;
- (1) *programme operator means a legal entity approved by the Authority to operate programme aircraft and manage a fractional ownership programme;*
 - (2) *a dry-lease aircraft exchange means an arrangement, documented by the written programme agreements, under which the programme aircraft are available, on an as needed basis without crew, to each fractional owner;*

Note. A dry-lease aircraft exchange arrangement may be included in the fractional ownership contract among all fractional owners.
 - (3) *a fractional owner means an individual or entity that possesses a minimum fractional ownership interest in;*
 - (i) one or more programme aircraft; or
 - (ii) a company holding title in the programme aircraft.
 - (4) *fractional ownership interest means the fractional ownership in*
 - (i) one or more programme aircraft; or
 - (ii) a company holding title in the programme aircraft.
 - (5) *a fractional ownership programme or programme means any system of aircraft ownership and exchange that consists of all of the following elements;*
 - (i) a fractional ownership contract among all fractional owners;
 - (ii) the provision for fractional ownership programme management services by a programme operator approved for a fractional ownership programme on behalf of the fractional owners of eligible airworthy aeroplanes under a fractional ownership programme management arrangement between the programme operator and the



fractional owners;

- (iii) one or more fractional owners per programme aircraft, with at least one programme aircraft having more than one owner;
- (iv) possession of at least a minimum fractional ownership interest in one or more programme aircraft by each fractional owner; and
- (v) a dry-lease aircraft exchange arrangement among all of the fractional owners.

Note. A dry-lease aircraft exchange arrangement may be included in the fractional ownership contract among all fractional owners.

- (6) *a fractional ownership programme aircraft or programme aircraft* means;
 - (i) an aircraft in which a fractional owner has a minimal fractional ownership interest and that has been included in the programme agreements, or
 - (ii) an aircraft owned in whole or in part by the programme operator that has been included in the dry-lease aircraft exchange and may be also used to supplement programme operations.
- (7) *a fractional ownership programme flight or programme flight* means a flight under OPS 2A, Part III when one or more passengers or property designated by a fractional owner are on board the aircraft;
- (8) *a minimum fractional ownership interest* means a fractional ownership interest equal to, or greater than;
 - (i) one-sixteenth (1/16) of at least one programme aeroplane; or
 - (ii) one-thirty-second (1/32) of shares in the company holding title in the programme aircraft, based on a fractional ownership programme including two (2) aircraft (additional programme aircraft may proportionally increase the fractional owner's minimum percentage of shares in the company).

**SUBPART B****CERTIFICATION****OPS 2A.1105 General rules for certification**

- (a) The programme operator shall not operate an aeroplane for the purpose of a fractional ownership programme otherwise than under, and in accordance with, the terms and conditions of the management specifications.
- (b) An applicant for a fractional ownership programme, or variation of the management specifications, shall allow the Authority to examine all safety aspects of the proposed operation.
- (c) An applicant for a fractional ownership programme and management specifications must;
 - (1) have a principal place of operations; and
 - (2) satisfy the Authority that the applicant is able to conduct safe operations.
- (d) The programme operator shall grant the Authority access to the organisation and aeroplanes and shall ensure that, with respect to maintenance, access is granted to any associated maintenance organisation, to determine continued compliance with airworthiness regulations.
- (e) The management specifications will be varied, suspended or revoked if the Authority is no longer satisfied that the operator can maintain safe operations.
- (f) The programme operator must satisfy the Authority that;
 - (1) its organisation and management are suitable and properly matched to the scale and scope of the operation; and
 - (2) procedures for the supervision of operations have been defined.
- (g) The programme operator shall nominate and employ an Accountable Manager acceptable to the Authority who has corporate authority for ensuring that all operations, training and maintenance activities can be financed and carried out to the standard required by the Authority.
- (h) The programme operator must have nominated persons acceptable to the Authority, who are responsible for the management and supervision of;
 - (1) flight operations;
 - (2) continuing airworthiness;
 - (3) crew training; and
 - (4) ground operations.
- (i) The programme operator shall ensure that every programme flight is conducted in accordance with the provisions of the programme operations manual.
- (j) The programme operator must arrange appropriate ground handling facilities to ensure the safe handling of its flights.



- (k) The programme operator shall ensure that its aeroplanes are equipped and its crews are qualified, as required for the area and type of operation.
- (l) The programme operator must comply with the continuing airworthiness requirements, in accordance with CAR CAMO, for all aeroplanes operated under the management specifications.
- (m) The programme operator must provide the Authority with a copy of the programme operations manual, as specified in Subpart G and all amendments or revisions to it.
- (n) The programme operator shall maintain permanently its ground handling responsibility, when all or part of the functions and tasks related to ground handling services have been contracted to a service provider.

OPS 2A.1110 Issue, variation and continued validity of management specifications

- (a) The programme operator will not be granted management specifications, or a variation thereto, and the management specifications will not remain valid unless:
 - (1) aeroplanes operated have a valid Certificate of Airworthiness;
 - (2) the continuing airworthiness system has been approved by the Authority in accordance with Subpart E; and
 - (3) he has satisfied the Authority that he has the ability to:
 - (i) establish and maintain an adequate organisation;
 - (ii) comply with required training programmes; and
 - (iii) comply with continuing airworthiness requirements, consistent with the nature and extent of the operations specified.
- (b) The Authority may require the operator to demonstrate their operational procedures by the conduct of one or more demonstration flights, operated as if they were programme flights to verify compliance with these regulations.
- (c) The Authority shall establish a system for both the certification and the continued surveillance of the operator to ensure that the required standards of operations established in OPS 2A, Part III are maintained.

OPS 2A.1115 Administrative requirements

- (a) The programme operator shall ensure that the following information is included in the initial application for a fractional ownership programme, and when applicable, any variation applied for:
 - (1) the official name and business name,
 - (2) address of principal place of operations and mailing address of the applicant;
 - (3) a description of the proposed operation;
 - (4) the name of the Accountable Manager;



- (5) the names of the nominated persons, including those responsible for flight operations, the continuing airworthiness system, crew training and ground operations, together with their qualifications and experience; and
 - (6) the programme operations manual.
- (b) In respect of the operator's continuing airworthiness only, the following information must be included in the initial application for fractional ownership programme and, when applicable, any variation applied for, and for each aeroplane type to be operated;
- (1) The operator's Continuing Airworthiness Management system;
 - (2) The operator's aeroplane maintenance programme(s);
 - (3) The aeroplane Technical Log;
 - (4) Where appropriate, the technical specification(s) of the maintenance contract(s) between the operator and any approved maintenance organisation;
- (c) The application for an initial issue of a fractional ownership programme must be submitted at least 90 days before the date of intended operation except that the programme operations manual may be submitted later but not less than 60 days before the date of intended operation.
- (d) The application for the variation of a fractional ownership programme must be submitted at least 30 days, or as otherwise agreed, before the date of intended operation.

OPS 2A.1120 The management and organisation

- (a) The issue of an approval for a fractional ownership programme and management specifications by the Authority shall be dependent upon the programme operator demonstrating an adequate organisation, method of control and supervision of flight operations, training programme as well as maintenance arrangements consistent with the nature and extent of the operations specified.
- (b) The continued validity of a fractional ownership programme and management specifications shall depend upon the programme operator maintaining these requirements. In particular;
- (1) General
 - (i) The programme operator must have a sound and effective management structure in order to ensure the safe conduct of air operations. Nominated persons must have managerial competency together with appropriate technical/operational qualifications in aviation.
 - (ii) Nominated persons
 - (A) A description of the functions and the responsibilities of the nominated persons, including their names, must be contained in the programme operations manual. Other than in exceptional circumstances, the Authority must be given notice at least 10 days' notice in writing of any intended or actual change in appointments or functions.
 - (B) The programme operator must make arrangements to ensure continuity of supervision in the absence of nominated persons.



- (C) Persons employed as nominated persons must be contracted to work sufficient hours to fulfil the management functions associated with the scale and scope of the operation.
- (2) Adequacy and supervision of staff
- (i) Crew members. The programme operator must employ sufficient flight and cabin crew for the planned operation, trained and checked in accordance with Subpart F and Subpart H as appropriate.
- (ii) Ground Staff
- (A) The number of ground staff is dependent upon the nature and the scale of operations. Operations departments, in particular, must be staffed by trained personnel who have a thorough understanding of their responsibilities within the organisation.
- (B) The programme operator contracting other organisations to provide certain services retains responsibility for the maintenance of proper standards. In such circumstances the Accountable Manager shall ensure that any contractor employed meets the required standards.
- (3) Supervision
- (i) The number of supervisors to be appointed is dependent upon the structure of the operator and the number of staff employed.
- (ii) The duties and responsibilities of these supervisors must be defined, and any other commitments arranged so that they can discharge their supervisory responsibilities.
- (iii) The supervision of crew members and ground staff must be exercised by individuals possessing experience and personal qualities sufficient to ensure the attainment of the standards specified in the programme operations manual.
- (4) Accommodation facilities
- (i) The programme operator must ensure that working space available at each designated operating base is sufficient for personnel pertaining to the safety of flight operations. Consideration must be given to the needs of ground staff, those concerned with operational control, the storage and display of essential records, and flight planning by crews.
- (ii) Office services must be capable, without delay, of distributing operational instructions and other information to all concerned.
- (5) Documentation
- The programme operator must make arrangements for the production of manuals, amendments and other documentation.



(6) Third Parties

The programme operator shall develop policies and procedures for third parties that perform work on its behalf.

OPS 2A.1125 Management specifications

- (a) Each programme operator shall conduct operations in accordance with management specifications issued by the Authority to the Accountable Manager on behalf of the programme operator.
- (b) Management specifications shall include;
- (1) The current list of all fractional owners and types of aircraft, registration markings and serial numbers.
 - (2) The authorisations, limitations, and certain procedures under which these operations are to be conducted.
 - (3) Certain other procedures under which each class and size of aircraft is to be operated.
 - (4) Authorisation for an aircraft maintenance inspection programme, including the type of aircraft, the registration markings and serial numbers of each aircraft to be operated under the programme. No person may conduct any programme flight using any aircraft not listed.
 - (5) Time limitations, or standards for determining time limitations, for overhauls, inspections, and checks for airframes, engines, propellers, appliances, and emergency equipment of aircraft.
 - (6) The specific location of the programme operator's principal base of operations and, if different, the address that will serve as the primary point of contact for correspondence between the Authority and the Accountable Manager and the name and mailing address of the programme operator 's agent for service.
 - (7) The specific location of the programme operator's other designated bases of operation;
 - (8) Other business names the Accountable Manager may use.
 - (9) Authorisation for the method of controlling weight and balance of aircraft.
 - (10) Any authorised deviation and exemption granted from any requirement of OPS 2A, Part III.
 - (11) Any other information the Authority determines is necessary.
- (c) The Accountable Manager shall notify the Authority of changes to the list of fractional owners and keep the current list of all fractional owners required by paragraph (b)(1) at its principal base of operation or other designated bases of operation referenced in its management specifications. The Accountable Manager shall make this list of fractional owners available for inspection by the Authority.
- (d) Management specifications issued are effective unless;
- (1) The management specifications are amended under OPS 2A.1130; or



- (2) The Authority suspends or revokes the management specifications.
- (e) At least 30 days before it proposes to establish or change the location of its principal base of operations, other designated base(s) of operations, or its main maintenance base, the Accountable Manager shall provide written notification to the Authority.
- (f) The Accountable Manager shall maintain a complete and separate set of its management specifications at its principal base of operations or other location referenced in its management specifications, and shall make its management specifications available for inspection by the fractional owner(s).
- (g) The Accountable Manager must insert pertinent excerpts of its management specifications, or references thereto, in its programme operations manual and must:
 - (1) clearly identify each such excerpt as a part of its management specifications; and
 - (2) state that compliance with each management specifications requirement is mandatory.
- (h) The Accountable Manager shall keep each of its employees and other persons who perform duties material to its operations informed of the provisions of its management specifications that apply to that employee's or person's duties and responsibilities.

OPS 2A.1130 Amendment to management specifications

- (a) The Authority may amend any management specifications if;
 - (1) the Authority determines that safety and the public interest require the amendment of any management specifications; or
 - (2) the Accountable Manager applies for the amendment of any management specifications, and the Authority determines that safety and the public interest allows the amendment.
- (b) Except as provided in paragraph (e) when the Authority initiates an amendment of the management specifications, the following procedure applies;
 - (1) The Authority will notify the Accountable Manager in writing of the proposed amendment.
 - (2) The Authority will set a reasonable period, but not less than 7 days, within which the Accountable Manager may submit written information, views, and arguments on the amendment.
 - (3) After considering all material presented, the Authority will notify the Accountable Manager of;
 - (i) The adoption of the proposed amendment;
 - (ii) The partial adoption of the proposed amendment, or
 - (iii) The withdrawal of the proposed amendment.
 - (4) If the Authority issues an amendment of the management specifications, it becomes effective once the Accountable Manager receives notice of it unless;



- (i) the Authority finds under paragraph (e) that there is an emergency requiring immediate action with respect to safety; or
 - (ii) the Accountable Manager petitions for reconsideration of the amendment under paragraph (d)
- (c) When the Accountable Manager applies for an amendment to its management specifications, the following procedure applies;
 - (1) The Accountable Manager must file an application to amend its management specifications;
 - (i) at least 90 days before the date proposed by the applicant for the amendment to become effective, unless a shorter time is approved, in cases such as mergers, acquisitions of operational assets that require an additional showing of safety (for example, proving tests or validation tests), and resumption of operations following a suspension of operations as a result of bankruptcy actions; or
 - (ii) at least 15 days before the date proposed by the applicant for the amendment to become effective in all other cases.
 - (2) The application must be submitted to the Authority in a form and manner prescribed by the Authority.
 - (3) After considering all material presented, the Authority will notify the Accountable Manager of;
 - (i) The adoption of the applied for amendment;
 - (ii) The partial adoption of the applied for amendment; or
 - (iii) The denial of the applied for amendment. The Accountable Manager may petition for reconsideration of a denial under paragraph (d)
 - (4) If the Authority approves the amendment, following coordination with the Accountable Manager regarding its implementation, the amendment is effective on the date the Authority approves it.
- (d) When the Accountable Manager seeks reconsideration of a decision of the Authority concerning the amendment of management specifications, the following procedure applies;
 - (1) The Accountable Manager must petition for reconsideration of that decision within 30 days of the date that the Accountable Manager receives a notice of denial of the amendment of its management specifications, or of the date it receives notice of an Authority-initiated amendment of its management specifications, whichever circumstance applies.
 - (2) The Accountable Manager must address its petition to the Director General.
 - (3) A petition for reconsideration, if filed within the 30-day period, suspends the effectiveness of any amendment issued by the Authority unless it has found, under paragraph (e) that an emergency exists requiring immediate action with respect to safety.
 - (4) If a petition for reconsideration is not filed within 30 days, the procedures of paragraph (c) apply.



- (e) If the Authority finds that an emergency exists requiring immediate action with respect to safety that makes the procedures set out in this section impracticable or contrary to the public interest;
- (1) the Authority amends the management specifications and makes the amendment effective on the day the Accountable Manager receives notice of it; and
 - (2) in the notice to the Accountable Manager, the Authority will articulate the reasons for its finding that an emergency exists requiring immediate action with respect to safety or that makes it impracticable or contrary to the public interest to stay the effectiveness of the amendment.

OPS 2A.1135 Conducting tests and inspections

- (a) At any time or place, the Authority may conduct an inspection or test, to determine whether the programme operator and Accountable Manager is complying with the applicable regulations and the management specifications.
- (b) The programme operator must allow the Authority to make any test or inspection to determine compliance respecting any matter stated in paragraph (a).
- (c) Each employee of, or person used by, the programme operator who is responsible for maintaining the records required by or necessary to demonstrate compliance must make those records available to the Authority.
- (d) The Authority may determine a programme operator's continued eligibility to hold its management specifications on any appropriate grounds.
- (e) Failure by any programme operator to make available to the Authority upon request, any required record, document, or report is grounds for suspension of all or any part of the management specifications.

OPS 2A.1140 Internal safety reporting and incident/accident response

- (a) The Accountable Manager shall establish an internal anonymous safety reporting procedure that fosters an environment of safety without any potential for retribution for filing the report.
- (b) The Accountable Manager shall establish procedures to respond to an aviation incident/accident.

Note: These procedures should be in accordance with the operator's SMS required by OPS 2A.1040.

**SUBPART C****FLIGHT OPERATIONS****OPS 2A.1205 Flight scheduling and locating requirements**

- (a) The Accountable Manager shall establish and use an adequate system to schedule and release programme aircraft.
- (b) The Accountable Manager shall have adequate procedures established for locating each flight.
- (c) Flight locating information must be retained at the Accountable Manager's principal base of operations, or at other places designated by the Accountable Manager in the flight locating procedures, until the completion of the flight.

OPS 2A.1210 Pilot in command and second in command

- (a) The Accountable Manager shall designate a;
 - (1) Pilot in command for each programme flight; and
 - (2) Second in command for each programme flight.
- (b) The pilot in command, as designated by the Accountable Manager, shall remain the pilot in command at all times during that flight.

OPS 2A.1215 Operating information required

- (a) The Accountable Manager shall, for all programme operations, provide the following materials, in current and appropriate form, accessible to the pilot at the pilot station, and the pilot must use them:
 - (1) a cockpit checklist in accordance with OPS 2A.230 and OPS 2A.415;
 - (2) at least one set of pertinent aeronautical charts in accordance with OPS 2A.402(d)(3); and
 - (3) for IFR operations, at least one set of pertinent navigational en-route, terminal area, and instrument approach procedure charts in accordance with OPS 2A.402(d)(3).
- (b) Each cockpit checklist required by paragraph (a)(1) shall contain the following procedures;
 - (1) Before starting engines;
 - (2) Before take-off;
 - (3) Cruise;
 - (4) Before landing;
 - (5) After landing; and
 - (6) Stopping engines.
- (c) Each emergency cockpit checklist shall contain the following procedures, as appropriate;



- (1) Emergency operation of fuel, hydraulic, electrical, and mechanical systems.
- (2) Emergency operation of instruments and controls.
- (3) Engine inoperative procedures.
- (4) Any other emergency procedures necessary for safety.

OPS 2A.1220 Passenger awareness

- (a) In addition to OPS 2A.204 prior to each take-off, the pilot in command of an aircraft carrying passengers on a programme flight shall ensure that all passengers have been verbally briefed by a crew member on;
 - (1) *Smoking*: Each passenger must be briefed on when, where, and under what conditions smoking is prohibited. This briefing must include a statement, as appropriate, that the regulations require passenger compliance with lighted passenger information signs and no smoking placards, prohibit smoking in lavatories, and require compliance with crew member instructions with regard to these items;
 - (2) The placement of seat backs in an upright position before take-off and landing and tray tables stowed;
 - (3) Ditching procedures and the use of flotation equipment required for a flight over water;
 - (4) Stowage of hand baggage;
 - (5) Restrictions on the use of portable electronic devices;
 - (6) Location and contents of the safety briefing card.
- (b) Prior to each take-off, the pilot in command of an aircraft carrying passengers on a programme flight shall ensure that each person who may need the assistance of another person to move expeditiously to an exit if an emergency occurs and that person's attendant, if any, has received a briefing as to the procedures to be followed if an evacuation occurs. This paragraph does not apply to a person who has been given a briefing before a previous leg of that flight in the same aircraft.
- (c) Prior to each take-off, the pilot in command shall advise the passengers of the name of the entity in operational control of the flight.
- (d) Parts of, or all of the briefing may be provided by an audio-visual presentation.
- (e) The verbal briefing required by paragraph (a) shall be supplemented by safety briefing cards that must be carried in the aircraft in locations convenient for the use of each passenger. The cards must;
 - (1) be appropriate for the aircraft on which they are to be used;
 - (2) contain a diagram of, and method of operating, the emergency exits; and
 - (3) contain other instructions necessary for the use of emergency equipment on board the aircraft.

**OPS 2A.1225 IFR take-off, approach and landing minimums**

- (a) No pilot on a programme aircraft operating a programme flight may begin an instrument approach procedure to an airport unless;
- (1) Either that airport or the alternate airport has a weather reporting facility operated by a source approved by the State where the airport is located; and
 - (2) The latest weather report issued by the weather reporting facility includes a current local altimeter setting for the destination airport. If no local altimeter setting is available at the destination airport, the pilot must obtain the current local altimeter setting from a source provided by the facility designated on the approach chart for the destination airport.
- (b) For flight planning purposes, if the destination airport does not have a weather reporting facility described in paragraph (a)(1) the pilot must designate as an alternate an airport that has a weather reporting facility meeting that criteria.
- (c) No person may take off an aircraft under IFR from an airport where weather conditions are at or above take-off minimums but are below authorised IFR landing minimums unless there is an alternate airport within one hour's flying time (at normal cruising speed, in still air) of the airport of departure.
- (d) Each pilot making an IFR take-off or approach and landing at an airport must comply with applicable instrument approach procedures and take-off and landing weather minimums prescribed by the authority having jurisdiction over the airport. In addition, no pilot may take off at that airport when the visibility is less than 150 m (500 feet) (for approach category A, B and C aeroplanes) or 200 m (650 feet) for approach category D aeroplanes, unless otherwise authorised in the specific approval.



This Page Intentionally Left Blank

**SUBPART D****PERFORMANCE OPERATING LIMITATIONS****OPS 2A.1305 Aeroplane limitations at destination and alternate airports**

- (a) A programme flight shall meet OPS 2A, Subpart D in all respects, and;
- (1) where the Aeroplane Flight Manual does not contain performance charts for landing on wet or contaminated runways, no person may take off an aeroplane when the appropriate weather reports or forecasts, or any combination of them, indicate that the runways at the destination or alternate airport may be wet or contaminated at the estimated time of arrival unless the effective runway length at the destination airport is at least 115 percent of the runway length required by the Aeroplane Flight Manual.



This Page Intentionally Left Blank

**SUBPART E****MAINTENANCE AND CONTINUING AIRWORTHINESS****OPS 2A.1405 Operator's continuing airworthiness responsibilities**

- (a) The programme operator shall ensure the airworthiness of the aeroplane and the serviceability of both operational and emergency equipment by complying with the relevant regulations as CAR AIR, CAR GEN & CAR 21.
- (b) The programme operator shall also comply with the requirements of OPS 2A.610.

OPS 2A.1410 General continuing airworthiness arrangements

- (a) The programme operator shall have arrangements for continuing airworthiness management to the requirements of these regulations.
- (b) The programme operator shall utilise the services of an acceptable organisation for the management of maintenance and continuing airworthiness.
- (c) An acceptable organisation is considered to be one of the following:
 - (1) An approved San Marino Continuing Airworthiness Management Organisation (CAMO), which performs the management of continuing airworthiness management tasks in compliance with CAR CAMO for the subject programme aircraft types operated and listed on the approval certificate.

Note: When the operator does not have an inhouse continuing airworthiness management organisation appropriately approved, arrangements must be made with an organisation approved by the Authority, to carry out these requirements. The arrangement must be in the form of a written contract between the Accountable Manager and the organisation detailing the functions.

- (d) An intention to change the organisation managing the continuing airworthiness shall be advised to the Authority at the earliest opportunity and shall not be made without the approval of the Authority.
- (e) The programme operator shall prepare and keep up to date a manual containing the continuing airworthiness management and maintenance information and instructions. The manual is required to be approved by the Authority.

OPS 2A.1415 Operator's Aeroplane Maintenance Programme

- (a) The operator must ensure that the aeroplane is maintained in accordance with the approved aeroplane maintenance programme. The maintenance programme must contain details, including frequency, of all maintenance required to be carried out. The maintenance programme will be required to include a reliability programme when the Authority determines that such a reliability programme is necessary.
- (b) The operator shall provide, for the use and guidance of maintenance and operational personnel concerned, a maintenance programme, approved by the Authority, containing the following information;



- (1) maintenance tasks and the intervals at which these are to be performed, taking into account the anticipated utilization of the aeroplane;
 - (2) when applicable, a continuing structural integrity programme;
 - (3) procedures for changing or deviating from (1) and (2) above; and
 - (4) when applicable, condition monitoring and reliability programme descriptions for aircraft systems, components and engines.
- (c) Maintenance tasks and intervals that have been specified as mandatory in approval of the type design shall be identified as such.
- (d) The design and application of the operator’s maintenance programme shall observe Human Factors principles.
- (e) Copies of all amendments to the maintenance programme shall be furnished promptly to all organisations or persons to whom the maintenance programme has been issued.
- (f) The operator’s approved aeroplane maintenance programme must be subject to periodic reviews and amended when necessary. The reviews will ensure that the maintenance programme continues to be valid in light of operating experience whilst taking into account new and/or modified maintenance instructions promulgated by the Type Certificate holder.
- (g) The operator’s approved aeroplane maintenance programme must reflect applicable mandatory regulatory requirements addressed in documents issued by the Authority and Type Certificate holder to comply with aircraft certification requirements.
- (h) The operator’s aeroplane maintenance programme and any subsequent amendment must be approved by the Authority, as the State of Registry.
- (i) The periods prescribed by the Authority’s approved maintenance programme may be varied by the operator provided that such variations are within the limits specified in OPS 2A.1415(j). Variations are only permitted when the periods prescribed by the maintenance programme, or documents in support of the maintenance programme, cannot be complied with due to circumstances which could not reasonably have been foreseen by the operator. Particulars of every variation so made shall be entered in the appropriate aircraft records.
- (j) The permitted variations to the maintenance programme in accordance with OPS 2A.1415(i) are;
- (1) Items Controlled by Flying Hours:

- 5000 flying hours or less;	10%
- More than 5000 flying hours;	500 flying hours
 - (2) Items Controlled by Calendar Time:

- 1 year or less:	10% or 1 month, whichever is the lesser
- More than 1 year but not exceeding 3 years:	2 months



- More than 3 years: 3 months
- (3) Items Controlled by Landing/Cycles:
 - 500 landings/cycles or less: 10% or 25 landings/cycles, whichever is the lesser
 - More than 500 landings/cycles: 10% or 500 landings/cycles, whichever is the lesser



This Page Intentionally Left Blank

**SUBPART F****FLIGHT CREW****OPS 2A.1505 Flight Crew****(a) Personnel**

- (1) The Accountable Manager and each fractional owner shall use in programme operations on programme aircraft, flight crews meeting the criteria of this Subpart. The Accountable Manager must provide oversight of those crew members.
- (2) The Accountable Manager shall employ (either directly or by contract) an adequate number of pilots per programme aircraft. Flight crew staffing must be determined based on the following factors, at a minimum:
 - (i) Number of programme aircraft.
 - (ii) Flight, duty, and rest time considerations, and in all cases within the limits set forth in OPS 2A.1510.
 - (iii) Vacations.
 - (iv) Operational efficiencies.
 - (v) Training.
- (3) The Accountable Manager shall publish pilot and cabin crew member duty schedules sufficiently in advance to follow the flight, duty, and rest time limits of OPS 2A.1510 in programme operations.
- (4) Unless otherwise authorised by the Authority, when any programme aircraft is flown in programme operations with passengers on board, the crew shall consist of at least two qualified pilots employed or contracted by the Accountable Manager or the fractional owner.
- (5) The Accountable Manager shall ensure that trained and qualified scheduling or flight release personnel are on duty to schedule and release programme aircraft during all hours that such aircraft are available for programme operations.

(b) Crew member experience

No Accountable Manager or fractional owner may use any person, nor may any person serve, as a pilot in command or second in command of a programme aircraft in programme operations unless that person has met the applicable licensing and medical requirements of the State of Licence issue including type rating, instrument rating and experience requirements.

(c) Pilot operating limitations and pairing requirement

- (1) The Accountable Manager is responsible for including pilot experience on type and operating limitation requirements in the programme operations manual taking into account weather and operational conditions.



- (2) The Accountable Manager is responsible for ensuring procedures are established, acceptable to the Authority, to prevent the crewing together of inexperienced flight crew members.
- (3) No person may be assigned in the capacity of pilot in command in a programme operation to more than two aircraft types that require a separate type rating.

OPS 2A.1510 Flight, duty and rest time requirements

- (a) Objective and Scope
 - (1) The operator shall, for the purpose of managing its fatigue related safety risks, establish and maintain flight time specification schemes that are appropriate to the type of operations performed.
 - (2) The operator shall, prior to being implemented, have approved by the Authority either;
 - (i) flight time, flight duty period, duty period limitations and rest period requirements that are within the prescribed fatigue management regulations described in CAR OPS 1 Subpart Q; or
 - (ii) a Fatigue Risk Management System (FRMS) in compliance with OPS 1.1140 for all operations; or
 - (iii) an FRMS in compliance with OPS 1.1140 for part of its operations and the requirements of sub-paragraph (i) above for the remainder of its operations.

OPS 2A.1515 Training - General

- (a) The Accountable Manager shall not use a training programme requiring the services of a training organisation unless that organisation is approved by the State of Licence issue, or acceptable to the Authority.
- (b) The Accountable Manager shall provide adequate training facilities and appropriately qualified instructors for any training required.
- (c) The Accountable Manager is responsible for establishing safe and efficient crew management practices for all phases of flight in programme operations including crew resource management training for all crew members used in programme operations.
- (d) The Accountable Manager shall not use a pilot on a programme flight unless that pilot has passed the licence proficiency check required by the State of Licence issue, which includes the instrument rating and additional tasks appropriate to the operations the licence holder is authorised to conduct.
- (e) The Accountable Manager shall not use a person for checking purposes unless that person meets the checking requirements of either the State of Licence issue, or the Authority when applicable.
- (f) The Accountable Manager shall not use a person for instructional purposes (aircraft or simulator) unless, with respect to the type, class, or category aircraft involved, that person meets the instructional requirements of the State of Licence issue, or the Authority when applicable.

**OPS 2A.1520 Training programme**

- (a) The training required under OPS 2A.730 shall be included in a training programme and include the following;
- (1) Prescribe the training and checking requirements of pilots for;
 - (i) *Induction training.* The training required for crew members who have not been involved in the programme operator's fractional ownership programme.
 - (ii) *Upgrade training.* The training required for crew members who have qualified and served as second in command on a particular aircraft type, before they serve as pilot in command on that aircraft.
 - (iii) *Crew member emergency and safety equipment training.* The training required under OPS 2A.1525.
 - (2) Prescribe the syllabus for each type of aircraft and variant for each crew member required for that type aircraft. The syllabus must include ground and flight training required.
 - (3) Prescribe the requirements for the qualification, approval and use of aircraft simulators and flight training devices in the conduct of an approved training programme;
 - (4) Prescribe training centres that conduct training, testing and checking under contract or other arrangements to crew members.
 - (5) Establish a training programme that ensures that each crew member and each person assigned duties for the carriage and handling of hazardous materials (as defined in CAR DG) is adequately trained to perform these assigned duties.

Note: A training programme with syllabus shall form part of the programme operations manual.

- (b) If authorised by the Authority, the Accountable Manager may comply with the applicable training and testing sections of CAR OPS 1, Subpart N, except for the operating experience requirements.

OPS 2A.1525 Crew member emergency and safety equipment training

- (a) The programme operator shall ensure that each flight crew member undergoes training and checking on the location and use of all emergency and safety equipment carried for each aircraft type. The period of validity of an emergency and safety equipment check shall be 12 calendar months in addition to the remainder of the month of issue. If issued within the final 3 calendar months of validity of a previous emergency and safety check, the period of validity shall extend from the date of issue until 12 calendar months from the expiry date of that previous emergency and safety equipment check.
- (b) Emergency training shall include the requirements of OPS 2A.1725(b).



This Page Intentionally Left Blank

**SUBPART G****MANUALS AND RECORDS****OPS 2A.1605 Programme operations manual requirements**

- (a) The Accountable Manager shall prepare and keep current a programme operation manual, acceptable to the Authority, setting forth procedures and policies of the fractional ownership programme. The Accountable Manager's management, flight, ground, and maintenance personnel must use this manual to conduct operations.
- (b) The programme operations manual shall also incorporate procedures for the subject areas of Appendix 1 to OPS 2A.215.
- (c) The Accountable Manager shall maintain at least one copy of the programme operations manual at its principal base of operations and other designated bases of operation.
- (d) Any operating procedures applicable to the principal base of operations or other designated bases of operation shall be included the programme operations manual.
- (e) No programme operations manual may be contrary to any applicable regulations, foreign regulations applicable to the programme flights in foreign countries, or the management specifications.
- (f) The Accountable Manager shall make the programme operations manual, or appropriate parts of the programme operations manual (and changes and additions), available to its maintenance and ground operations personnel and must furnish the programme operations manual to;
 - (1) its crew members; and
 - (2) the Authority.
- (g) Each employee of the programme operator to whom a programme operations manual or appropriate portions of it are furnished under paragraph (f)(1) must keep it up-to-date with the changes and additions furnished to them.
- (h) Except as provided in paragraph (j) the appropriate parts of the programme operations manual shall be carried on each aircraft when away from the principal base of operations or designated base of operation. The appropriate parts must be available for use by ground or flight personnel.
- (i) For the purpose of complying with paragraph (f) the Accountable Manager shall furnish the persons listed therein with all or part of its programme operations manual in the English language. If the Accountable Manager furnishes all or part of the manual in other than printed form, it must ensure there is a compatible reading device available to those persons that provides a legible image of the maintenance information and instructions, or a system that is able to retrieve the maintenance information and instructions in the English language.
- (j) If the Accountable Manager conducts aircraft inspections or maintenance at specified facilities where the approved aircraft inspection programme is available, the Accountable Manager is not required to ensure that the approved aircraft inspection programme is carried aboard the aircraft en-route to those facilities.
- (k) Programme operators that are also certificated to operate under CAR OPS 1 may be authorised to use the operations manual required by CAR OPS 1 to meet the manual requirements, provided;



- (1) the policies and procedures are consistent for both operations, or
- (2) when policies and procedures are different, the applicable policies and procedures are identified and used.

OPS 2A.1610 Programme operations manual contents

The manual must include the subject areas of Appendix 1 to CAR OPS 2A.215 and must include the following;

- (a) Procedures for ensuring compliance with aircraft weight and balance limitations;
- (b) Copies of the management specifications or appropriate extracted information, including area of operations authorised, category and class of aircraft authorised, crew complements, and types of operations authorised;
- (c) Procedures for complying with accident notification requirements;
- (d) Procedures for ensuring that the pilot in command knows that required airworthiness inspections have been made and that the aircraft has been approved for return to service in compliance with applicable maintenance requirements;
- (e) Procedures for reporting and recording mechanical irregularities that come to the attention of the pilot in command before, during, and after completion of a flight;
- (f) Procedures to be followed by the pilot in command for determining that mechanical irregularities or defects reported for previous flights have been corrected or that correction of certain mechanical irregularities or defects have been deferred;
- (g) Procedures to be followed by the pilot in command to obtain maintenance, preventive maintenance, and servicing of the aircraft at a place where previous arrangements have not been made by the Accountable Manager or fractional owner, when the pilot is authorised to so act for the operator;
- (h) MEL procedures for the release of, and continuation of flight if any item of equipment required for the particular type of operation becomes inoperative or unserviceable en-route;
- (i) Procedures for refuelling aircraft, eliminating fuel contamination, protecting from fire (including electrostatic protection), and supervising and protecting passengers during refuelling;
- (j) Procedures to be followed by the pilot in command in the briefing under OPS 2A.1220.
- (k) Procedures for ensuring compliance with emergency procedures, including a list of the functions assigned each category of required crew members in connection with emergency and emergency evacuation duties;
- (l) The approved aircraft inspection programme, when applicable;
- (m) Procedures for the evacuation of persons who may need the assistance of another person to move expeditiously to an exit if an emergency occurs;
- (n) Procedures for performance planning that take into account take off, landing and en-route conditions;



- (o) A suitable system (which may include a coded or electronic system) that provides for preservation and retrieval of maintenance record keeping information in a manner acceptable to the Authority that provides;
 - (1) A description (or reference to date acceptable to the Authority) of the work performed;
 - (2) The name of the person performing the work if the work is performed by a person outside the organisation of the Accountable Manager; and
 - (3) The name or other positive identification of the individual approving the work.
- (p) Flight locating and scheduling procedures; and
- (q) Flight/duty time and rest requirements for flight and cabin crew;
- (r) Other procedures and policy instructions regarding programme operations that are issued by the Accountable Manager or required by the Authority; such as
 - (1) Safety Management Systems; and
 - (2) Quality Management Systems, where applicable.

OPS 2A.1615 Recordkeeping

- (a) The Accountable Manager must keep at its principal base of operations or at other places approved by the Authority, and must make available for inspection by the Authority all of the following;
 - (1) The management specifications;
 - (2) A current list of the aircraft used or available for use in operations and the operations for which each is equipped (for example, RNP5/10, RVSM, etc.);
 - (3) A copy of the current Specific Approval issued for each aircraft under CAR OPS 2A.104.
 - (4) An individual record of each pilot used in operations, including the following information;
 - (i) The full name of the pilot.
 - (ii) The pilot licence (by type and number), ratings and validations, if applicable, that the pilot holds.
 - (iii) The pilot's aeronautical experience in sufficient detail to determine the pilot's qualifications to pilot aircraft in operations.
 - (iv) The pilot's current duties and the date of the pilot's assignment to those duties.
 - (v) The effective date and class of the medical certificate that the pilot holds.
 - (vi) The date and result of each of the initial and recurrent competency tests and proficiency checks and the type of aircraft flown during that test or check.
 - (vii) The pilot's flight time in sufficient detail to determine compliance with the flight time limitations.



- (viii) The pilot's training or checking authorisation, if any.
 - (ix) Any action taken concerning the pilot's release from employment for physical or professional disqualification; and
 - (x) The date of the satisfactory completion of initial, upgrade, and differences training and each recurrent training phase.
- (5) An individual record for each cabin crew member used in operations, including the following information:
- (i) The full name of the cabin crew member, and
 - (ii) The date and result of training required by Subpart H, as applicable.
- (6) A current list of all fractional owners and associated aircraft. This list or a reference to its location must be included in the management specifications and should be of sufficient detail to determine the minimum fractional ownership interest of each aircraft.
- (7) A record of the following;
- (i) Operational Flight Plan;
 - (ii) Aeroplane Technical Log;
 - (iii) Details of the filed ATS flight plan;
 - (iv) Appropriate NOTAM/AIS briefing documentation; and
 - (v) Appropriate meteorological information.
- (b) The Accountable Manager must keep each record required by paragraph (a) for at least 6 months. When an employee is no longer employed with the programme operator or fractional owner, each record required by paragraphs (a)(4) and (a)(5) must be retained for at least 12 months.
- (c) The Accountable Manager is responsible for ensuring the preparation and accuracy of a load manifest in duplicate containing information concerning the loading of the aircraft. The manifest must be prepared before each take-off and must include;
- (1) The number of passengers;
 - (2) The total weight of the loaded aircraft;
 - (3) The maximum allowable take-off weight for that flight;
 - (4) The centre of gravity limits;
 - (5) The centre of gravity of the loaded aircraft, except that the actual centre of gravity need not be computed if the aircraft is loaded according to a loading schedule or other approved method that ensures that the centre of gravity of the loaded aircraft is within approved limits. In those cases, an entry must be made on the manifest indicating that the centre of gravity is within limits according to a loading schedule or other approved method;



- (6) The registration number of the aircraft or flight number;
 - (7) The origin and destination; and
 - (8) Identification of crew members and their crew position assignments.
- (d) The pilot in command of the aircraft for which a load manifest must be prepared must carry a copy of the completed load manifest in the aircraft to its destination. The Accountable Manager must ensure that copies of completed load manifest are kept for at least 3 months at its principal operations base, or at another location used by it and approved by the Authority.
- (e) Records may be kept either in paper or digital format provided there are means of displaying a digital copy.



This Page Intentionally Left Blank

**SUBPART H****CABIN CREW****OPS 2A.1705 General**

- (a) No Accountable Manager or fractional owner may use any person, nor may any person serve, as a cabin crew member on a programme aircraft in programme operations, unless that person has met the applicable experience, training and checking as required by this Subpart.

Note: For the purpose of this regulation, “cabin crew member” means any crew member, other than a flight crew member, who performs, in the interests of safety of passengers, duties assigned to him/her by the operator or the commander in the cabin of an aeroplane.

- (b) The Accountable Manager shall establish and maintain an approved cabin crew member training and checking programme, that is appropriate to the operations to which each cabin crew member is to be assigned and will ensure that they acquire the competency to perform their assigned duties.
- (c) The programme operator shall, for a programme flight, ensure that all cabin crew members wear a cabin crew uniform that is clearly identifiable to the passengers as a cabin crew member.
- (d) Other personnel, such as medical staff, security staff, child minders, escorts, technical staff, entertainers, interpreters, who undertake tasks in the cabin, shall not wear a uniform which might identify them to passengers as a cabin crew member, unless they comply with the training and experience requirements of this Subpart and any other applicable requirements of OPS 2A, Part III.
- (e) Minimum number and composition of cabin crew shall comply with the requirements of OPS 1.990.
- (f) Minimum requirements for cabin crew shall comply with the requirements of OPS 1.995.
- (g) The programme operator or the approved training organisation providing the training course shall ensure that during or following completion of the training required by OPS 1.1005, OPS 1.1010 and OPS 1.1015, each cabin crew member undergoes a check covering the training received in order to verify his proficiency in carrying out normal and emergency safety duties.
- (h) The period of validity of initial and recurrent check shall be 12 calendar months in addition to the remainder of the month of issue. If issued within the final 3 calendar months of validity of previous check, the period of validity shall extend from the date of issue until 12 calendar months from the expiry date of that previous check.
- (i) The operator shall ensure that each cabin crew member does not operate on more than three aeroplane types except that, with the approval of the Authority, the cabin crew member may operate on four aeroplane types, provided that for at least two of the types:
- (1) non-type-specific normal and emergency procedures are identical; and
 - (2) safety equipment and type-specific normal and emergency procedures are similar.
- (j) For the purposes of paragraph (i) above, variants of an aeroplane type are considered to be different types if they are not similar in each of the following aspects:
- (1) emergency exit operation;



- (2) location and type of portable safety equipment; and
- (3) type-specific emergency procedures.

OPS 2A.1710 Training & Checking

- (a) The training and checking required for cabin crew members shall form part of the programme operator's training and checking programme and include the following:
 - (1) *Initial safety training and checking.* The initial training and checking required for cabin crew members to obtain an attestation of initial training shall comply with OPS 1.1005. A cabin crew member shall not be used unless they hold an attestation of initial training and check from a training organisation that the crew member has acquired sufficient general knowledge and basic proficiency required to perform the duties and discharge the responsibilities related to the safety of passengers and flight during normal, abnormal and emergency operations.
 - (2) *Conversion and differences training.* Conversion and differences training and checking shall comply with CAR OPS 1.1010.
 - (3) *Recurrent training.* The training and checking required for crew members to remain adequately trained and currently proficient for each aircraft crew member position, and type of operation in which the crew member serves. This recurrent training shall comply with OPS 1.1015.
 - (4) *Refresher training.* The training and checking required in CAR OPS 1.1020 for cabin crew members previously trained and qualified, but who have become unqualified because of been absent from all flying duties for more than 6 months;
- (b) Prescribe training centres that conduct training, testing and checking under contract or other arrangements to cabin crew members.
- (c) Prescribe awareness training for the identification, carriage and handling of hazardous materials (as defined in CAR DG).

Note: A training programme with syllabus shall form part of the programme operations manual.

OPS 2A.1720 Training Records

- (a) The operator shall:
 - (1) Maintain records of all training and checking required by OPS 2A.1715; and
 - (2) keep a copy of the attestation of safety training; and
 - (3) keep the training records and records of medical examinations or assessments up to date, showing in the case of the training records the dates and contents of the conversion, differences and recurrent training received; and
 - (4) Make the records of all initial, conversion and recurrent training and checking available, on request, to the cabin crew member concerned.