



CAR AGA VOLUME II

HELIPORTS

FOREWORD

CONTENTS

REVISION RECORD

LIST of EFFECTIVE PAGES



This Page Intentionally Left Blank



FOREWORD

1. The Republic of San Marino Civil Aviation Authority, known in these regulations as the “Authority” has implemented CAR AGA, Volume II (Civil Aviation Regulations – Heliports). Appendices to ICAO Annex 14 Volume II are not included in these regulations and require compliance when referred to.

Note: Refer to CAR AGA, Volume I for Aerodromes, Air Routes and Ground Aids.

2. [The structure and substance of these regulations is based on Annex 14, Volume II, Amendment 10 to the Convention on International Civil Aviation.]
3. Unless otherwise stated, applicable CAR DEF definitions and abbreviations are used throughout this document.
4. The editing practices used in this document are as follows:
 - (a) ‘Shall’ or ‘Will’ or ‘Must’ is used to indicate a mandatory requirement.
 - (b) ‘Should’ is used to indicate a recommendation.
 - (c) ‘May’ is used to indicate discretion by the Authority, the industry or the applicant, as appropriate.

Note: The use of the male gender implies the female gender and vice versa.

5. Paragraphs and sub-paragraphs with new, amended and corrected text will be enclosed within brackets until a subsequent “amendment” is issued.
6. Manuals related to the specifications of CAR AGA Volume II;
 - (a) Aerodrome Design Manual (Doc 9157)
 - Part 1 — Runways
 - Part 2 — Taxiways, Aprons and Holding Bays
 - Part 3 — Pavements
 - Part 4 — Visual Aids
 - Part 5 — Electrical Systems
 - Part 6 — Frangibility
 - (b) Airport Planning Manual (Doc 9184)
 - Part 1 — Master Planning
 - Part 2 — Land Use and Environmental Control
 - Part 3 — Guidelines for Consultant/Construction Services
 - (c) Airport Services Manual (Doc 9137)
 - Part 1 — Rescue and Fire Fighting
 - Part 2 — Pavement Surface Conditions
 - Part 3 — Wildlife Control and Reduction
 - Part 4 — Fog Dispersal (withdrawn)
 - Part 5 — Removal of Disabled Aircraft
 - Part 6 — Control of Obstacles
 - Part 7 — Airport Emergency Planning
 - Part 8 — Airport Operational Services



Part 9 — Airport Maintenance Practices

- (d) Heliport Manual (Doc 9261)
- (e) Manual of Surface Movement Guidance and Control Systems (SMGCS) (Doc 9476)
- (f) Manual on the ICAO Bird Strike Information System (IBIS) (Doc 9332)
- (g) Stolport Manual (Doc 9150)
- (h) World Geodetic System — 1984 (WGS-84) Manual (Doc 9674).



REVISION RECORD

REVISION NO.	EFFECTIVE DATE	ENTERED BY <i>(Hardcopy only)</i>
Initial Issue (Rev 00)	01 October 2016	
Rev 01	01 December 2016	
Rev 02	01 July 2019	
Rev 03	01 January 2021	
Rev 04	01 January 2026	



CONTENTS

CHAPTER 1 GENERAL	1-1
1.1 Definitions.....	1-1
1.2 Applicability	1-1
1.3 Common reference systems	1-2
1.3.1 Horizontal reference system.....	1-2
1.3.2 Vertical reference system.....	1-2
1.3.3 Temporal reference system	1-2
CHAPTER 2 HELIPORT DATA	2-1
2.1 Aeronautical data	2-1
2.2 Heliport reference point	2-1
2.3 Heliport elevations	2-1
2.4 Heliport dimensions and related information	2-1
2.5 Declared distances.	2-2
2.6 Coordination between aeronautical information services and heliport authorities.....	2-2
2.7 Rescue and firefighting.....	2-3
CHAPTER 3 PHYSICAL CHARACTERISTICS	3-1
3.1 Onshore heliports	3-1
Final approach and take-off areas	3-1
Safety areas	3-3
Protected side slope	3-3
Helicopter clearways	3-4
Touchdown and lift-off areas	3-4
Helicopter taxiways and taxi-routes	3-6
Helicopter taxiways.....	3-7
Helicopter taxi-routes	3-7
Helicopter ground taxi-routes.....	3-8
Helicopter air taxi-routes.....	3-9
Helicopter stands	3-9
Protection areas	3-10
Location of a final approach and take-off area in relation to a runway or taxiway.....	3-11
3.2 Helidecks.....	3-14
Final approach and take-off areas and touchdown and lift-off areas	3-14
3.3 Shipboard heliports	3-15
Final approach and take-off areas and touchdown and lift-off areas	3-15
CHAPTER 4 OBSTACLE ENVIRONMENT	4-1
4.1 Obstacle limitation surfaces and sectors	4-1
Approach surface	4-1
Transitional surface	4-2
Take-off climb surface	4-2
Obstacle-free sector/surface — helidecks	4-3
Limited obstacle sector/surface — helidecks	4-4
4.2 Obstacle limitation requirements	4-5
[Onshore heliports].	4-5
[]	



Helidecks	4-6
Shipboard heliports	4-7
Purpose-built heliports located forward or aft	4-7
Amidships location – purpose-built and non-purpose-built.....	4-7
Non-purpose-built heliports – Ship’s side location.....	4-8
Winching areas	4-8
CHAPTER 5 VISUAL AIDS	5-1
5.1. Wind direction indicators	5-1
5.2. Markings and markers.	5-1
5.2.1 Winching area marking.....	5-2
5.2.2 Heliport identification marking.....	5-2
5.2.3 Maximum allowable mass marking	5-4
5.2.4 D-value marking	5-6
5.2.5 Final approach and take-off area perimeter marking or markers for surface-level heliports	5-7
5.2.6 Final approach and take-off area designation markings for runway-type FATOs	5-9
5.2.7 Aiming point marking.....	5-9
5.2.8 Touchdown and lift-off area perimeter marking	5-9
5.2.9 Touchdown/positioning marking	5-10
5.2.10 Heliport name marking	5-12
5.2.11 Helideck obstacle-free sector (chevron) marking	5-12
5.2.12 Helideck and shipboard heliport surface marking	5-13
5.2.13 Helicopter taxiway markings and markers	5-14
5.2.14 Helicopter air taxi-route markings and markers	5-15
5.2.15 Helicopter stand markings.....	5-15
5.2.16 Flight path alignment guidance marking	5-17
5.3. Lights	5-18
5.3.1 General.....	5-18
5.3.2 Heliport beacon.....	5-19
5.3.3 Approach lighting system	5-20
5.3.4 Flight path alignment guidance lighting system	5-22
5.3.5 Visual alignment guidance system.....	5-22
5.3.6 Visual approach slope indicator.....	5-23
5.3.7 Final approach and take-off area lighting systems for onshore surface-level heliports....	5-23
5.3.8 Aiming point lights	5-24
5.3.9 Touchdown and lift-off area (TOLA) lighting system	5-24
5.3.10 Helicopter stand floodlighting	5-26
5.3.11 Winching area floodlighting.....	5-26
5.3.12 Taxiway lights	5-27
5.3.13 Visual aids for denoting obstacles	5-27
5.3.14 Floodlighting of obstacles.....	5-27
CHAPTER 6 HELIPORT EMERGENCY RESPONSE	6-1
6.1 Heliport emergency planning	6-1
6.2 Rescue and firefighting	6-2



CHAPTER 1

GENERAL

Note: CAR AGA, Volume II, contains regulations that prescribe the physical characteristics and obstacle limitation surfaces to be provided for at heliports, and certain facilities and technical services normally provided at a heliport.

Please note that provisions for helicopter flight operations are contained in CAR OPS 2H for private operations and CAR OPS 3 for commercial air transport operations.

1.1 Definitions

Unless otherwise stated, applicable CAR DEF definitions and abbreviations are used throughout this document.

1.2 Applicability

- (a) The dimensions discussed in these regulations are based on consideration of single-main-rotor helicopters.
- (b) For tandem-rotor helicopters the heliport design will be based on a case-by-case review of the specific models using the basic requirement for a safety area and protection areas specified in this regulation.
- (c) The specifications of the main chapters of these regulations are applicable for visual heliports that may or may not incorporate the use of a Point-in-space approach or departure.
- (d) Additional specifications for instrument heliports with non-precision and/or precision approaches and instrument departures are detailed in the Appendix to ICAO Annex 14, Volume II.
- (e) The specifications of these regulations are not applicable for water heliports (touchdown or lift-off on the surface of the water).

1.2.1 The interpretation of some of the specifications in these regulations expressly requires the exercising of discretion, the taking of a decision or the performance of a function by the Authority. In other specifications, the expression Authority does not actually appear although its inclusion is implied. In both cases, the responsibility for whatever determination or action is necessary shall rest with the Authority having jurisdiction over the heliport.

1.2.2 The specifications in these regulations shall apply to all heliports intended to be used by helicopters in international civil aviation. They shall apply equally to areas for the exclusive use of helicopters at an aerodrome primarily meant for the use of aeroplanes. Where relevant, the provisions of CAR AGA, Volume I shall apply to the helicopter operations being conducted at such an aerodrome.

1.2.3 Unless otherwise specified, the specification for a colour referred to within this volume shall be that contained in Appendix 1 to ICAO Annex 14, Volume I.



1.3 Common reference systems

1.3.1 Horizontal reference system

World Geodetic System — 1984 (WGS-84) shall be used as the horizontal (geodetic) reference system. Reported aeronautical geographical coordinates (indicating latitude and longitude) shall be expressed in terms of the WGS-84 geodetic reference datum.

1.3.2 Vertical reference system

Mean sea level (MSL) datum, which gives the relationship of gravity-related height (elevation) to a surface known as the geoid, shall be used as the vertical reference system.

1.3.3 Temporal reference system

1.3.3.1 The Gregorian calendar and Coordinated Universal Time (UTC) shall be used as the temporal reference system.

1.3.3.2 When a different temporal reference system is used, this shall be indicated in GEN 2.1.2 of the Aeronautical Information Publication (AIP) of the Italian Republic.

Note: Under an Agreement with ENAC, the San Marino requirements are stated in the Italian AIP.



CHAPTER 2

HELIPORT DATA

2.1 Aeronautical data

- 2.1.1 Determination and reporting of heliport-related aeronautical data shall be in accordance with the accuracy and integrity classification required to meet the needs of the end-user of aeronautical data.
- 2.1.2 Digital data error detection techniques shall be used during the transmission and/or storage of aeronautical data and digital data sets.

2.2 Heliport reference point

- 2.2.1 A heliport reference point shall be established for a heliport or a landing location not collocated with an aerodrome.
- 2.2.2 The heliport reference point shall be located near the initial or planned geometric centre of the heliport and shall normally remain where first established.
- 2.2.3 The position of the heliport reference point shall be measured and reported to the aeronautical information services authority in degrees, minutes and seconds.

2.3 Heliport elevations

- 2.3.1 The heliport elevation and geoid undulation at the heliport elevation position shall be measured and reported to the aeronautical information services authority to the accuracy of one-half metre or foot.
- 2.3.2 The elevation of the TLOF and/or the elevation and geoid undulation of each threshold of the FATO (where appropriate) shall be measured and reported to the aeronautical information services authority to the accuracy of one-half metre or foot.

2.4 Heliport dimensions and related information

- 2.4.1 The following data shall be measured or described, as appropriate, for each facility provided on a heliport:
 - (a) heliport type — surface-level, elevated, shipboard or helideck;
 - (b) TLOF — dimensions to the nearest metre or foot, slope, surface type, bearing strength in tonnes (1 000 kg);
 - (c) FATO — type of FATO, true bearing to one-hundredth of a degree, designation number (where appropriate), length and width to the nearest metre or foot, slope, surface type;
 - (d) safety area — length, width and surface type;
 - (e) helicopter taxiway and helicopter taxi-route — designation, width, surface type;
 - (f) apron — surface type, helicopter stands;



- (g) [approach surface — when elevated, the height of the inner edge above the FATO;

Note: When the take-off climb surface is elevated, its inner edge and height will be the outer edge of the elevated helicopter clearway as specified in 4.1.14.]

- (h) helicopter clearway — length, ground profile, or, when elevated, height above the FATO, length and width; and]
- (i) visual aids for approach procedures, marking and lighting of FATO, TLOF, helicopter ground taxiways, helicopter air taxiways and helicopter stands.

2.4.2 The geographical coordinates of the geometric centre of the TLOF and/or of each threshold of the FATO (where appropriate) shall be measured and reported to the aeronautical information services authority in degrees, minutes, seconds and hundredths of seconds.

2.4.3 The geographical coordinates of appropriate centre line points of helicopter taxiways and helicopter taxi routes shall be measured and reported to the aeronautical information services authority in degrees, minutes, seconds and hundredths of seconds.

2.4.4 The geographical coordinates of each helicopter stand shall be measured and reported to the aeronautical information services authority in degrees, minutes, seconds and hundredths of seconds.

2.4.5 The geographical coordinates of obstacles in Area 2 (the part within the heliport boundary) and in Area 3 shall be measured and reported to the aeronautical information services authority in degrees, minutes, seconds and tenths of seconds. In addition, the top elevation, type, marking and lighting (if any) of obstacles shall be reported to the aeronautical information services authority.

2.5 Declared distances

The following distances to the nearest metre or foot shall be declared, where relevant, for a heliport:

- (a) take-off distance available;
- (b) rejected take-off distance available; and
- (c) landing distance available.

2.6 Coordination between aeronautical information services and heliport authorities

2.6.1 To ensure that aeronautical information services units obtain information to enable them to provide up-to-date pre-flight information and to meet the need for in-flight information, arrangements shall be made between aeronautical information services and heliport authorities responsible for heliport services to report to the responsible aeronautical information services unit, with a minimum of delay:

- (a) [information on the status of certification of heliports and information on heliport conditions;]
- (b) the operational status of associated facilities, services and navigation aids within their area of responsibility;
- (c) any other information considered to be of operational significance.



- 2.6.2 Before introducing changes to the air navigation system, due account shall be taken by the services responsible for such changes of the time needed by the aeronautical information service for the preparation, production and issue of relevant material for promulgation. To ensure timely provision of the information to the aeronautical information service, close coordination between those services concerned is therefore required.
- 2.6.3 Of a particular importance are changes to aeronautical information that affect charts and/or computer-based navigation systems which qualify to be notified by the aeronautical information regulation and control (AIRAC) system, as specified in Annex 15, Chapter 6 and Appendix 4. The predetermined, internationally agreed AIRAC effective dates in addition to 14 days postage time shall be observed by the responsible heliport services when submitting the raw information/data to aeronautical information services.
- 2.6.4 The heliport services responsible for the provision of raw aeronautical information/data to the aeronautical information services shall do that while taking into account accuracy and integrity requirements for aeronautical data as specified in Appendix 1 to ICAO Annex 14, Volume II.
- 2.7 Rescue and firefighting**
- 2.7.1 Information concerning the level of protection provided at a heliport for helicopter rescue and firefighting purposes shall be made available.
- 2.7.2 The level of protection normally available at a heliport should be expressed in terms of the category of the rescue and firefighting service as described in 6.2 and in accordance with the types and amounts of extinguishing agents normally available at the heliport.
- 2.7.3 Changes in the level of protection normally available at a heliport for rescue and firefighting shall be notified to the appropriate aeronautical information services units and, where applicable, air traffic units to enable them to provide the necessary information to arriving and departing helicopters. When such a change has been corrected, the above units shall be advised accordingly.
- 2.7.4 A change should be expressed in terms of the new category of the rescue and firefighting service available at the heliport.



This Page Intentionally Left Blank



CHAPTER 3

PHYSICAL CHARACTERISTICS

3.1 Onshore heliports

Final approach and take-off areas (FATO)

3.1.1 A FATO shall:

(a) provide:

- (1) an area free of obstacles, except for essential objects which because of their function are located on it, and of sufficient size and shape to ensure containment of every part of the design helicopter in the final phase of approach and commencement of take-off in accordance with the intended procedures;

Note: Essential objects are visual aids (e.g. lighting) or others (e.g. firefighting systems) necessary for safety purposes. For further requirements regarding penetration of a FATO by essential objects, see 3.1.4.

- (2) when solid, a surface which is resistant to the effects of rotor downwash; and
 - (i) when collocated with a TLOF, is contiguous and flush with the TLOF; has bearing strength capable of withstanding the intended loads; and ensures effective drainage; or
 - (ii) when not collocated with a TLOF, is free of hazards should a forced landing be required; and

Note: Resistant implies that effects from the rotor downwash neither cause a degradation of the surface nor result in flying debris.

(b) be associated with a safety area.

3.1.2 A heliport shall be provided with at least one FATO, which need not be solid.

3.1.3 The minimum dimensions of a FATO shall be:

(a) where intended to be used by helicopters operated in performance class 1:

- (1) the length of the Rejected Take-Off Distance (RTOD) for the required Take-Off procedure prescribed in the helicopter flight manual (HFM) of the helicopters for which the FATO is intended, or 1.5 Design D, whichever is greater; and
- (2) the width for the required procedure prescribed in the HFM of the helicopters for which the FATO is intended, or 1.5 Design D, whichever is greater.

(b) where intended to be used by helicopters operated in performance classes 2 or 3, the lesser of:

- (1) an area within which can be drawn a circle of diameter of 1.5 Design D; or,



- (2) when there is a limitation on the direction of approach and touchdown, an area of sufficient width to meet the requirement of 3.1.1(a)(1) but not less than 1.5 times the overall width of the design helicopter.

Note 1: The RTOD is intended to ensure containment of the helicopter during a rejected take-off. Although some flight manuals provide the RTOD, in others the dimension provided is the “minimum demonstrated ... size” (where “...” could be “heliport”, “runway”, “helideck” etc.) and this may not include helicopter containment. When this is the case, it is necessary to consider sufficient safety area dimensions as well as the dimensions of 1.5·D for the FATO, should the HFM not deliver data.

Note 2: Local conditions, such as elevation, temperature, and permitted manoeuvring may need to be considered when determining the size of a FATO.

3.1.4 Essential objects located in a FATO shall not penetrate a horizontal plane at the FATO elevation by more than 5 cm.

3.1.5 When the FATO is solid the slope should not:

- (a) except as provided in (b) or (c) below; exceed 2 per cent in any direction;
- (b) when the FATO is elongated and intended to be used by helicopters operated in performance class 1, exceed 3 per cent overall, or have a local slope exceeding 5 per cent; and
- (c) when the FATO is elongated and intended to be used solely by helicopters operated in performance class 2 or 3, exceed 3 per cent overall, or have a local slope exceeding 7 per cent.

3.1.6 The FATO should be located so as to minimize the influence of the surrounding environment, including turbulence, which could have an adverse impact on helicopter operations.

3.1.7 A FATO shall be surrounded by a safety area which need not be solid.



Figure 3-1. FATO and associated safety area



Safety areas

3.1.8 A safety area shall provide:

- (a) an area free of obstacles, except for essential objects which because of their function are located on it, to compensate for manoeuvring errors; and
- (b) when solid, a surface which: is contiguous and flush with the FATO; is resistant to the effects of rotor downwash; and ensures effective drainage.

3.1.9 The safety area surrounding a FATO shall extend outwards from the periphery of the FATO for a distance of at least 3 m or 0.25 Design D, whichever is greater. (See Figure 3-1)

3.1.10 No mobile object shall be permitted in a safety area during helicopter operations.

3.1.11 Essential objects located in the safety area shall not penetrate a surface originating at the edge of the FATO at a height of 25 cm above the plane of the FATO sloping upwards and outwards at a gradient of 5 per cent.

3.1.12 When solid, the slope of the safety area should not exceed an upward slope of 4 per cent outwards from the edge of the FATO.

Protected side slope

3.1.13 A heliport shall be provided with at least one protected side slope rising at 45 degrees from the edge of the safety area and extending to a distance of 10 m, (See Figure 3-2)

3.1.14 A heliport should be provided with at least two protected side slopes, rising at 45 degrees outward from the edge of the safety area and extending to a distance of 10 m.

3.1.15 The surface of a protected side slope shall not be penetrated by obstacles.

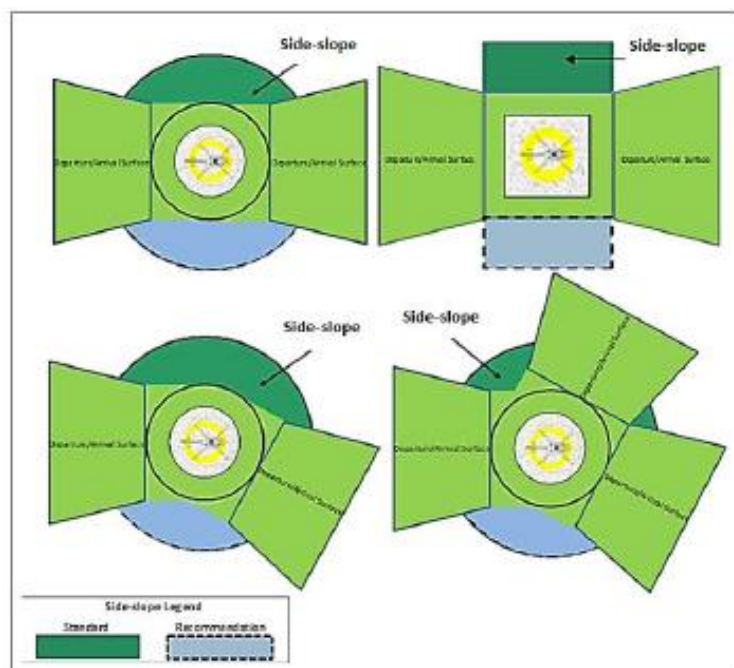

Figure 3-2 FATO simple/complex safety area and side slope protection



Note: These diagrams show a number of configurations of FATO/Safety Areas/Side slopes. For a more complex arrival/departure arrangement which consists of: two surfaces that are not diametrically opposed; more than two surfaces; or an extensive obstacle free sector (OFS) which abuts directly to the FATO, it can be seen that appropriate provisions are necessary to ensure that there are no obstacles between the FATO and/or safety area and the arrival/departure surfaces.

Helicopter clearways

Note: The inclusion of detailed specifications for helicopter clearways in this section is not intended to imply that a clearway has to be provided.

3.1.16 A helicopter clearway shall provide:

- (a) [an area free of obstacles, except for essential objects which because of their function are located on it, and of sufficient size and shape to ensure containment of the design helicopter when it is accelerating to achieve its safe climbing speed;
- (b) when solid, a surface which: is contiguous and flush with the FATO and safety area, is resistant to the effects of rotor downwash; and is free of hazards if a forced landing is required; or
- (c) when elevated, clearance above all obstacles.

3.1.17 When a helicopter clearway is provided, the inner edge shall be located;

- (a) at the outer edge of the safety area; or
- (b) when elevated, directly above, or directly below, the outer edge of the safety area.]

3.1.18 The width of a helicopter clearway should not be less than the width of the FATO and associated safety area. (See Figure 3-1)

3.1.19 When solid, the ground in a helicopter clearway should not project above a surface having an overall upward slope of 3 per cent or having a local upward slope exceeding 5 per cent, the lower limit of this surface being a horizontal line which is located on the periphery of the FATO.

3.1.20 An object situated in a helicopter clearway, which may endanger helicopters in the air, should be regarded as an obstacle and should be removed.

Touchdown and lift-off areas

3.1.21 A TLOF shall:

- (a) provide:
 - (1) an area free of obstacles and of sufficient size and shape to ensure containment of the undercarriage of the most demanding helicopter the TLOF is intended to serve in accordance with the intended orientation;
 - (2) a surface which:



- (i) has sufficient bearing strength to accommodate the dynamic loads associated with the anticipated type of arrival of the helicopter at the designated TLOF;
 - (ii) is free of irregularities that would adversely affect the touchdown or lift-off of helicopters;
 - (iii) has sufficient friction to avoid skidding of helicopters or slipping of persons;
 - (iv) is resistant to the effects of rotor downwash; and
 - (v) ensures effective drainage while having no adverse effect on the control or stability of a helicopter during touchdown and lift-off, or when stationary; and
- (b) be associated with a FATO or a stand.

3.1.22 A heliport shall be provided with at least one TLOF.

3.1.23 A TLOF shall be provided whenever it is intended that the undercarriage of the helicopter will touch down within a FATO or stand, or lift off from a FATO or stand.

3.1.24 The minimum dimensions of a TLOF shall be:

- (a) when in a FATO intended to be used by helicopters operated in performance class 1, the dimensions for the required procedure prescribed in the helicopter flight manuals (HFMs) of the helicopters for which the TLOF is intended; and
- (b) when in a FATO intended to be used by helicopters operated in performance classes 2 or 3, or in a stand:
 - (1) when there is no limitation on the direction of touchdown, of sufficient size to contain a circle of diameter of at least 0.83 D of:
 - (i) in a FATO, the design helicopter; or
 - (ii) in a stand, the largest helicopter the stand is intended to serve;
 - (2) when there is a limitation on the direction of touchdown, of sufficient width to meet the requirement of 3.1.21 (a)(1) above but not less than twice the undercarriage width (UCW) of:
 - (i) in a FATO, the design helicopter; or,
 - (ii) in a stand, the most demanding helicopter the stand is intended to serve.

3.1.25 For an elevated heliport, the minimum dimensions of a TLOF, when in a FATO, shall be of sufficient size to contain a circle of diameter of at least 1 Design-D.

3.1.26 Slopes on a TLOF should not:

- (a) except as provided in (b) or (c) below; exceed 2 per cent in any direction;



- (b) when the TLOF is elongated and intended to be used by helicopters operated in performance class 1; exceed 3 per cent overall, or have a local slope exceeding 5 per cent; and
- (c) when the TLOF is elongated and intended to be used solely by helicopters operated in performance class 2 or 3, exceed 3 per cent overall, or have a local slope exceeding 7 per cent.

3.1.27 *When a TLOF is within a FATO it should be:*

- (a) centred on the FATO; or
- (b) for an elongated FATO, centred on the longitudinal axis of the FATO.

3.1.28 When a TLOF is within a helicopter stand, it shall be centred on the stand.

3.1.29 A TLOF shall be provided with markings which clearly indicate the touchdown position and, by their form, any limitations on manoeuvring.

Note: When a TLOF in a FATO is larger than the minimum dimensions, the TDPM may be offset while ensuring containment of the undercarriage within the TLOF and the helicopter within the FATO.

3.1.30 Where an elongated Performance Class 1 FATO/TLOF contains more than one TDPM, measures should be in place to ensure that only one can be used at a time.

3.1.31 Where alternative TDPMs are provided they should be placed to ensure containment of the undercarriage within the TLOF and the helicopter within the FATO.

Note: The efficacy of the rejected take-off or landing distance will be dependent upon the helicopter being correctly positioned for take-off, or landing.

3.1.32 Safety devices such as safety nets or safety shelves shall be located around the edge of an elevated heliport but shall not exceed the height of the TLOF.

Helicopter taxiways and taxi-routes

Note 1: The specifications for ground taxi-routes and air taxi-routes are intended for the safety of simultaneous operations during the manoeuvring of helicopters. The effect of wind velocity/turbulence induced by the rotor downwash would need to be considered.

Note 2: The defined areas addressed in this section are taxiways and ground/air taxi-routes:

- (a) *Taxiways associated with air taxi-routes may be used by both wheeled and skidded helicopters for either ground or air taxiing.*
- (b) *Ground taxi-routes are meant for use by wheeled helicopters, for ground taxiing only.*
- (c) *Air taxi-routes are meant for use by air taxiing only.*



Helicopter taxiways

Note 1: A helicopter ground taxiway is intended to permit the surface movement of a wheeled helicopter under its own power.

Note 2: A helicopter taxiway can be used by a wheeled helicopter for air taxi if associated with a helicopter air taxi-route.

Note 3: When a taxiway is intended for use by aeroplanes and helicopters, the provisions for aeroplane taxiways, taxiway strips; helicopter taxiways; and taxi-routes will be taken into consideration and the more stringent requirements will be applied.

3.1.33 A helicopter taxiway shall:

- (a) provide:
 - (1) an area free of obstacles and of sufficient width to ensure containment of the undercarriage of the most demanding wheeled helicopter the taxiway is intended to serve;
 - (2) a surface which:
 - (i) has bearing strength to accommodate the taxiing loads of the helicopters the taxiway is intended to serve;
 - (ii) is free of irregularities that would adversely affect the ground taxiing of helicopters;
 - (iii) is resistant to the effects of rotor downwash; and
 - (iv) ensures effective drainage while having no adverse effect on the control or stability of a wheeled helicopter when being manoeuvred under its own power, or when stationary; and
- (b) be associated with a taxi-route.

3.1.34 The minimum width of a helicopter taxiway shall be the lesser of:

- (a) two times the undercarriage width (UCW) of the most demanding helicopter the taxiway is intended to serve; or
- (b) a width meeting the requirements of 3.1.33(a)(1).

3.1.35 The transverse slope of a taxiway should not exceed 2 per cent and the longitudinal slope should not exceed 3 per cent.

Note: A helicopter clearway would need to be considered when the heliport is intended to be used by helicopters operating in performance class 1.

Helicopter taxi-routes

3.1.36 A helicopter taxi-route shall provide:



- (a) an area free of obstacles, except for essential objects which because of their function are located on it, established for the movement of helicopters; with sufficient width to ensure containment of the largest helicopter the taxi-route is intended to serve;
- (b) when solid, a surface which is resistant to the effects of rotor downwash; and
 - (1) when collocated with a taxiway:
 - (i) is contiguous and flush with the taxiway;
 - (ii) does not present a hazard to operations; and
 - (iii) ensures effective drainage; and
 - (2) when not collocated with a taxiway:
 - (i) is free of hazards if a forced landing is required.

3.1.37 No mobile object shall be permitted on a ground taxi-route during helicopter movements operations.

3.1.38 When solid and collocated with a taxiway, the taxi-route should not exceed an upward transverse slope of 4 per cent outwards from the edge of the taxiway.

Helicopter ground taxi-routes

3.1.39 A helicopter ground taxi-route shall have a minimum width of 1.5 x the overall width of the largest helicopter it is intended to serve, and be centred on a taxiway. (See Figure 3-3)

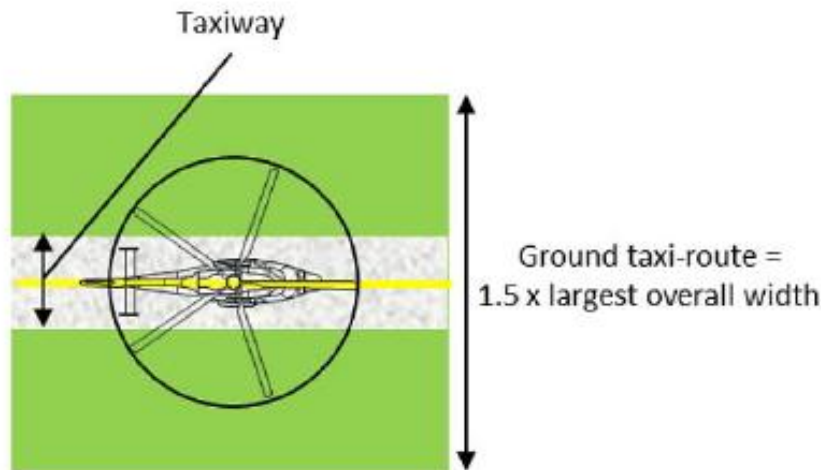

Figure 3-3. Helicopter taxiway/ground taxi-route

3.1.40 Essential objects located in a helicopter ground taxi-route shall not:

- (a) be located at a distance of less than 50 cm outwards from the edge of the helicopter ground taxiway; and
- (b) penetrate a surface originating 50 cm outwards of the edge of the helicopter taxiway and a height of 25 cm above the surface of the taxiway and sloping upwards and outwards at a gradient of 5 per cent.



Helicopter air taxi-routes

Note: A helicopter air taxi-route is intended to permit the movement of a helicopter above the surface at a height normally associated with ground effect and at ground speed less than 37km/h (20 kt).

3.1.41 A helicopter air taxi-route shall have a minimum width of twice the overall width of the largest helicopter it is intended to serve.

3.1.42 If collocated with a taxiway for the purpose of permitting both ground and air taxi operations (See Figure 3-4):

- (a) the helicopter air taxi-route shall be centred on the taxiway; and
- (b) essential objects located in the helicopter air taxi-route shall not:
 - (1) be located at a distance of less than 50 cm outwards from the edge of the helicopter taxiway; and
 - (2) penetrate a surface originating 50 cm outwards of the edge of the helicopter taxiway and a height of 25 cm above the surface of the taxiway and sloping upwards and outwards at a gradient of 5 per cent.

3.1.43 When not collocated with a taxiway, the slopes of the surface of an air taxi-route should not exceed the slope landing limitations of the helicopters that the taxi-route is intended to serve. In any event, the transverse slope should not exceed 10 per cent and the longitudinal slope should not exceed 7 per cent.

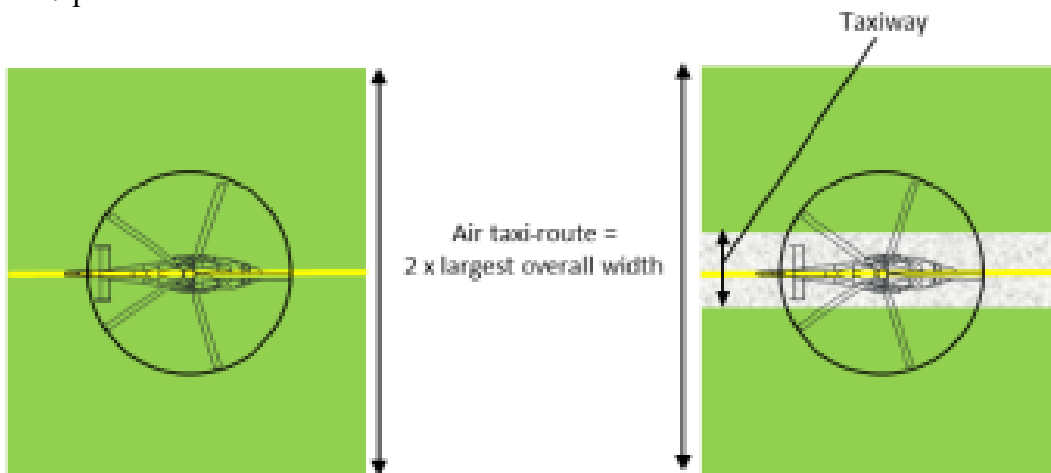

Figure 3-4. Helicopter air taxi-route and combined air taxi-route/taxiway

Helicopter stands

Note: The provisions of this section do not specify the location for helicopter stands but allow a high degree of flexibility in the overall design of the heliport. However, it is not considered good practice to locate helicopter stands under a flight path.

3.1.44 A helicopter stand shall:

- (a) provide:



- (1) an area free of obstacles and of sufficient size and shape to ensure containment of every part of the largest helicopter the stand is intended to serve when it is being positioned within the stand;
- (2) a surface which:
 - (i) is resistant to the effects of rotor downwash;
 - (ii) is free of irregularities that would adversely affect the manoeuvring of helicopters;
 - (iii) has bearing strength capable of withstanding the intended loads;
 - (iv) has sufficient friction to avoid skidding of helicopters or slipping of persons; and
 - (v) ensures effective drainage while having no adverse effect on the control or stability of a wheeled helicopter when being manoeuvred under its own power, or when stationary; and
- (b) be associated with a protection area.

3.1.45 The minimum dimensions of a helicopter stand shall be:

- (a) a circle of diameter of 1.2 D of the largest helicopter the stand is intended to serve; or
- (b) when there is a limitation on manoeuvring and positioning, of sufficient width to meet the requirement of 3.1.44 a) 1) above but not less 1.2 times overall width of largest helicopter the stand is intended to serve.

Note 1: For a helicopter stand intended to be used for taxi-through only, a width less than 1.2D but which provides containment and still permits all required functions of a stand to be performed, might be used (in accordance with 3.1.44 a) 1)).

Note 2: For a helicopter stand intended to be used for turning on the ground, the minimum dimensions may be influenced by the turning circle data provided by the manufacturer and are likely to exceed 1.2 D.

3.1.46 The mean slope of a helicopter stand in any direction should not exceed 2 per cent.

3.1.47 Each helicopter stand shall be provided with positioning markings to clearly indicate where the helicopter is to be positioned and, by their form, any limitations on manoeuvring.

3.1.48 A stand shall be surrounded by a protection area which need not be solid.

Protection areas

3.1.49 A protection area shall provide:

- (a) an area free of obstacles, except for essential objects which because of their function are located on it; and



- (b) when solid, a surface which is contiguous and flush with the stand; is resistant to the effects of rotor downwash; and ensures effective drainage.

3.1.50 When associated with a stand designed for turning, the protection area shall extend outwards from the periphery of the stand for a distance of 0.4D. (See Figure 3.5).

3.1.51 When associated with a stand designed for taxi-through, the minimum width of the stand and protection area shall not be less than the width of the associated taxi-route (see Figures 3.6 and 3.7).

3.1.52 When associated with a stand designed for non-simultaneous use (see Figures 3.8 and 3.9):

- (a) the protection area of adjacent stands may overlap but shall not be less than the required protection area for the larger of the adjacent stands; and
- (b) the adjacent non-active stand may contain a static object but it shall be wholly within the boundary of the stand.

Note: To ensure that only one of the adjacent stands is active at a time, instruction to pilots in the AIP make clear that a limitation on the use of the stands is in force.

3.1.53 No mobile object shall be permitted in a protection area during helicopter operations.

3.1.54 Essential objects located in the protection area shall not:

- (a) if located at a distance of less than 0.75 D from the centre of the helicopter stand, penetrate a surface at a height of 5 cm above the surface of the central zone; and
- (b) if located at a distance of 0.75 D or more from the centre of the helicopter stand, penetrate a surface at a height of 25 cm above the plane of the central zone and sloping upwards and outwards at a gradient of 5 per cent.

3.1.55 When solid, the slope of a protection area should not exceed an upward slope of 4 per cent outwards from the edge of the stand.

Location of a final approach and take-off area in relation to a runway or taxiway

3.1.56 Where a FATO is located near a runway or taxiway, and where simultaneous operations are planned, the separation distance between the edge of a runway or taxiway and the edge of a FATO shall not be less than the appropriate dimension in Table 3-1.

3.1.57 A FATO should not be located:

- (a) near taxiway intersections or holding points where jet engine efflux is likely to cause high turbulence; or
- (b) near areas where aeroplane vortex wake generation is likely to exist.



If aeroplane mass and/or helicopter mass are	Distance between FATO edge and runway edge or taxiway edge
up to but not including 3 175 kg	60 m
3 175 kg up to but not including 5 760 kg	120 m
5 760 kg up to but not including 100 000 kg	180 m
100 000 kg and over	250 m

Table 3-1. FATO minimum separation distance for simultaneous operations

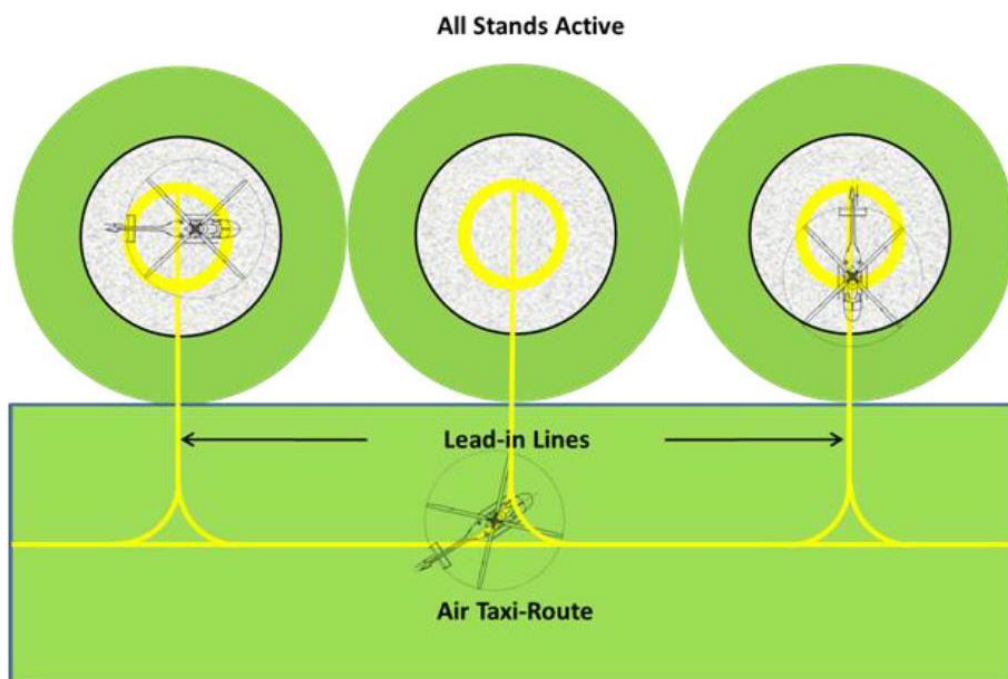

Figure 3-5. Turning stands (with air taxi-routes) — simultaneous use

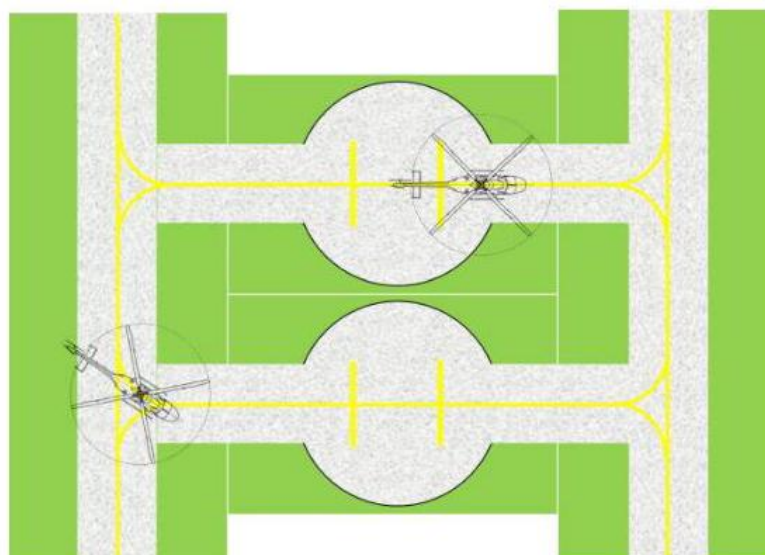

Figure 3-6. Ground taxi-through stands (with taxiway/ground taxi-route) simultaneous use

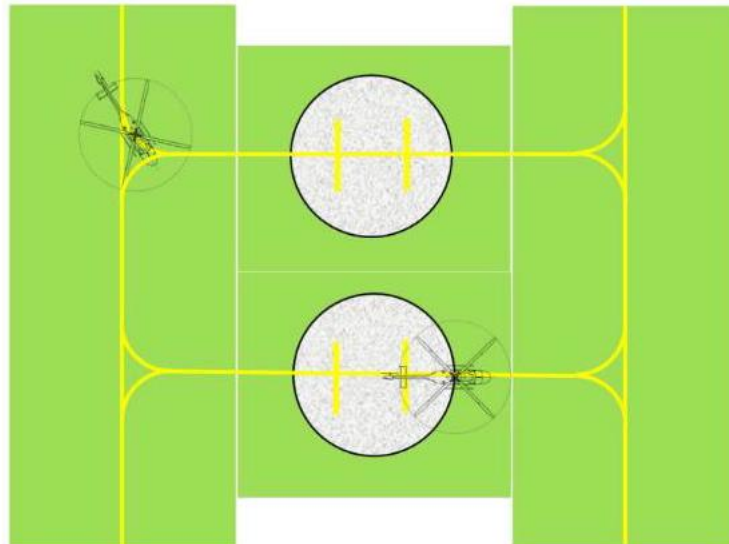

Figure 3-7. Air taxi-through stands (with air taxi-route) simultaneous use

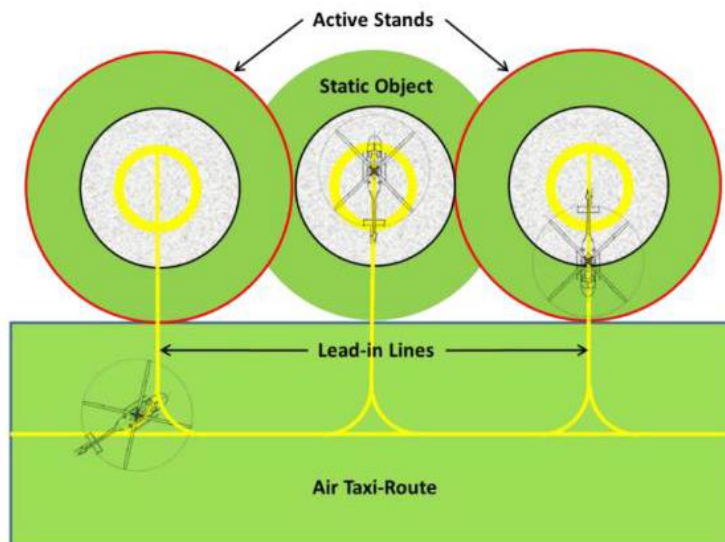

Figure 3-8. Turning stands (with air taxi-route) – non-simultaneous use – outer stands active

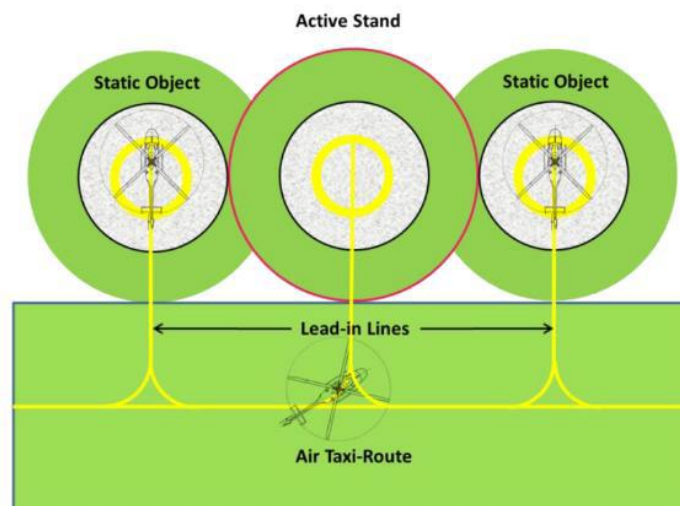

Figure 3-9. Turning stands (with air taxi-route) – non-simultaneous use – inner stands active



3.2 Helidecks

Note: The following specifications are for helidecks located on structures engaged in such activities as mineral exploitation, research or construction. See 3.4 for shipboard heliport provisions.

Final approach and take-off areas and touchdown and lift-off areas

Note 1: For helidecks that have a 1 D or larger FATO it is presumed that the FATO and the TLOF will always occupy the same space and have the same load bearing characteristics so as to be coincidental.

Note 2: For helidecks that are less than 1 D, the reduction in size is only applied to the TLOF which is a load bearing area. In this case, the FATO remains at 1 D but the portion extending beyond the TLOF perimeter need not be load bearing for helicopters. The TLOF and the FATO may be assumed to be collocated.

- 3.2.1 [The specifications in paragraphs 3.2.14 and 3.2.15 shall be applicable for helidecks completed on or after 01 January 2012.]
- 3.2.2 A helideck shall be provided with one FATO and one coincident or collocated TLOF.
- 3.2.3 A FATO may be any shape but shall be of sufficient size to contain an area within which can be accommodated a circle of diameter of not less than 1 D of the largest helicopter the helideck is intended to serve.
- 3.2.4 [A TLOF may be any shape but, subject to an appropriate risk assessment, shall be of sufficient size to contain an area within which can be accommodated a circle of diameter not less than 0.83 D of the largest helicopter the helideck is intended to serve.
- 3.2.5 The TLOF should be of sufficient size to contain an area within which can be accommodated a circle of diameter of not less than 1 D of the largest helicopter the helideck is intended to serve.]
- 3.2.6 A helideck shall be arranged to ensure that a sufficient and unobstructed air-gap is provided which encompasses the full dimensions of the FATO.
- 3.2.7 The FATO shall be located so as to avoid, as far as is practicable, the influence of environmental effects, including turbulence, over the FATO, which could have an adverse impact on helicopter operations.
- 3.2.8 The TLOF shall be dynamic load-bearing.
- 3.2.9 The TLOF shall provide ground effect.
- 3.2.10 No fixed object shall be permitted around the edge of the TLOF except for frangible objects, which, because of their function, must be located thereon.
- 3.2.11 For any TLOF 1 D or greater and any TLOF designed for use by helicopters having a D-value of greater than 16.0 m, objects installed in the obstacle-free sector whose function requires them to be located on the edge of the TLOF shall not exceed a height of 25 cm.



- 3.2.12 For any TLOF ID or greater and any TLOF designed for use by helicopters having a D-value of greater than 16.0 m, objects installed in the obstacle-free sector whose function requires them to be located on the edge of the TLOF, shall not exceed a height of 15 cm.
- 3.2.13 For any TLOF designed for use by helicopters having a D value of 16 m or less, and any TLOF having dimensions of less than 1 D, objects installed in the obstacle-free sector whose function requires them to be located on the edge of the TLOF shall not exceed a height of 5 cm.
- 3.2.14 Objects whose function requires them to be located within the TLOF (such as lighting or nets) shall not exceed a height of 2.5 cm. Such objects shall only be present if they do not represent a hazard to helicopters.

Note: Examples of potential hazards include nets or raised fittings on the deck that might induce dynamic rollover for helicopters equipped with skids.

- 3.2.15 Safety devices such as safety nets or safety shelves shall be located around the edge of a helideck but shall not exceed the height of the TLOF.
- 3.2.16 The surface of the TLOF shall be skid-resistant to both helicopters and persons and be sloped to prevent pooling of water.

3.3 Shipboard heliports

- 3.3.1 The specifications in paragraph 3.4.16 and 3.4.17 shall be applicable to shipboard heliports completed on or after 01 January 2012 and 01 January 2015, respectively.
- 3.3.2 When helicopter operating areas are provided in the bow or stern of a ship or are purpose-built above the ship's structure, they shall be regarded as purpose-built shipboard heliports.

Final approach and take-off areas and touchdown and lift-off areas

- 3.3.3 A shipboard heliport shall be provided with one FATO and one coincidental or collocated TLOF.
- 3.3.4 A FATO shall be circular, square or octagonal and of sufficient size to contain an area within which can be accommodated a circle of diameter of not less than 1 D of the largest helicopter the heliport is intended to serve.
- 3.3.5 The TLOF of a shipboard heliport shall be dynamic load-bearing.
- 3.3.6 The TLOF of a shipboard heliport shall provide ground effect.
- 3.3.7 For purpose-built shipboard heliports provided in a location other than the bow or stern, the TLOF shall be of sufficient size to contain a circle with a diameter not less than 1 D of the largest helicopter the heliport is intended to serve.
- 3.3.8 For purpose-built shipboard heliports provided in the bow or stern of a ship, the TLOF shall be of sufficient size to:
- (a) contain a circle with a diameter not less than 1 D of the largest helicopter the heliport is intended to serve; or



- (b) for operations with limited touchdown directions, contain an area within which can be accommodated two opposing arcs of a circle with a diameter of not less than 1 D in the helicopter's longitudinal direction. The minimum width of the heliport shall be not less than 0.83 D. (See Figure 3-10.)
- (c) The ship should be manoeuvred to ensure that the relative wind is appropriate to the direction of the helicopter touchdown heading.
- (d) The touchdown heading of the helicopter should be limited to the angular distance subtended by the 1 D arc headings, minus the angular distance which corresponds to 15 degrees at each end of the arc.

- 3.3.9 For non-purpose-built shipboard heliports, the TLOF shall be of sufficient size to contain a circle with a diameter not less than 1 D of the largest helicopter the heliport is intended to serve.
- 3.3.10 A shipboard heliport shall be arranged to ensure that a sufficient and unobstructed air-gap is provided which encompasses the full dimensions of the FATO.
- 3.3.11 The FATO shall be located to avoid the influence of environmental effects, including turbulence, over the FATO, which could have an adverse impact on helicopter operations.
- 3.3.12 [No fixed object shall be permitted around the edge of the TLOF except for objects, which, because of their function, must be located thereon.]
- 3.3.13 For any TLOF 1D or greater and any TLOF designed for use by helicopters having a D-value of greater than 16.0 m, objects installed in the obstacle-free sector whose function requires them to be located on the edge of the TLOF shall not exceed a height of 25 cm.
- 3.3.14 For any TLOF 1D or greater and any TLOF designed for use by helicopters having a D-value of greater than 16.0 m, objects installed in the obstacle-free sector whose function requires them to be located on the edge of the TLOF shall not exceed a height of 15 cm.
- 3.3.15 For any TLOF designed for use by helicopters having a D-value of 16.0 m or less, and any TLOF having dimensions of less than 1D, objects in the obstacle-free sector, whose function requires them to be located on the edge of the TLOF, shall not exceed a height of 5 cm.
- 3.3.16 Objects whose function requires them to be located within the TLOF (such as lighting or nets) shall not exceed a height of 2.5 cm. Such objects shall only be present if they do not represent a hazard to helicopters.
- 3.3.17 Safety devices such as safety nets or safety shelves shall be located around the edge of a shipboard heliport, except where structural protection exists, but shall not exceed the height of the TLOF.
- 3.3.18 The surface of the TLOF shall be skid-resistant to both helicopters and persons.

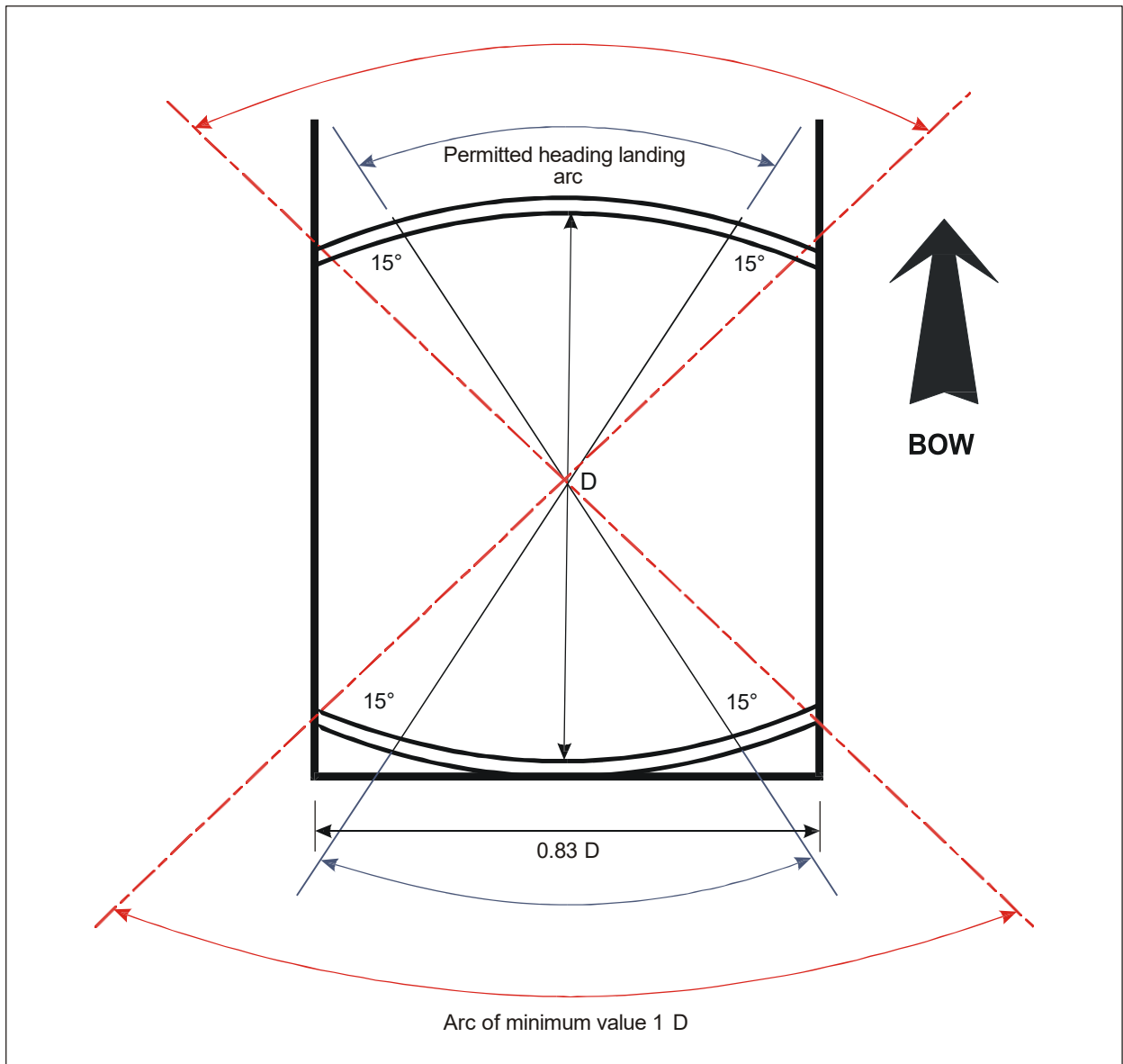

Figure 3-10. Shipboard permitted landing headings for limited heading operations



This Page Intentionally Left Blank



CHAPTER 4

OBSTACLE ENVIRONMENT

4.1 Obstacle limitation surfaces and sectors

Approach surface

4.1.1 *[Description.* An inclined plane or a combination of planes or, when a turn or turns are involved, a complex surface sloping upwards from the inner edge and centred on a line passing through the centre of the FATO.]

4.1.2 *Characteristics.* The limits of an approach surface shall comprise:

- (a) [an inner edge, horizontal and perpendicular to the centre line of the approach surface, with a minimum width equal to the specified width/diameter of the FATO plus the safety area, and located at;
 - (1) the outer edge of the safety area; or
 - (2) when vertical procedures are being utilized, directly above the outer edge of the safety area.]
- (b) two side edges originating at the ends of the inner edge diverging uniformly at a specified rate from the vertical plane containing the centre line of the FATO; and:
- (c) an outer edge horizontal and perpendicular to the centre line of the approach surface at;
 - (1) [a height of 152 m (500 ft) above the elevation of the FATO; or
 - (2) when a PinS approach procedure with proceed visually instruction is defined, a specified height above the elevation of the FATO.]

4.1.3 [The elevation of the inner edge shall be;

- (a) the elevation of the FATO at the point on the inner edge that is intersected by the centre line of the approach surface, or
- (b) when vertical procedures are being utilized; the level at which obstacle clearance is achieved.]

4.1.4 The slope(s) of the approach surface shall be measured in the vertical plane containing the centre line of the surface.

4.1.5 [In the case of an approach surface involving a turn or turns, the surface shall be a complex surface containing the horizontal normals to its centre line and the slope of the centre line shall be the same as that for a straight approach surface. (See Figure 4-1)]

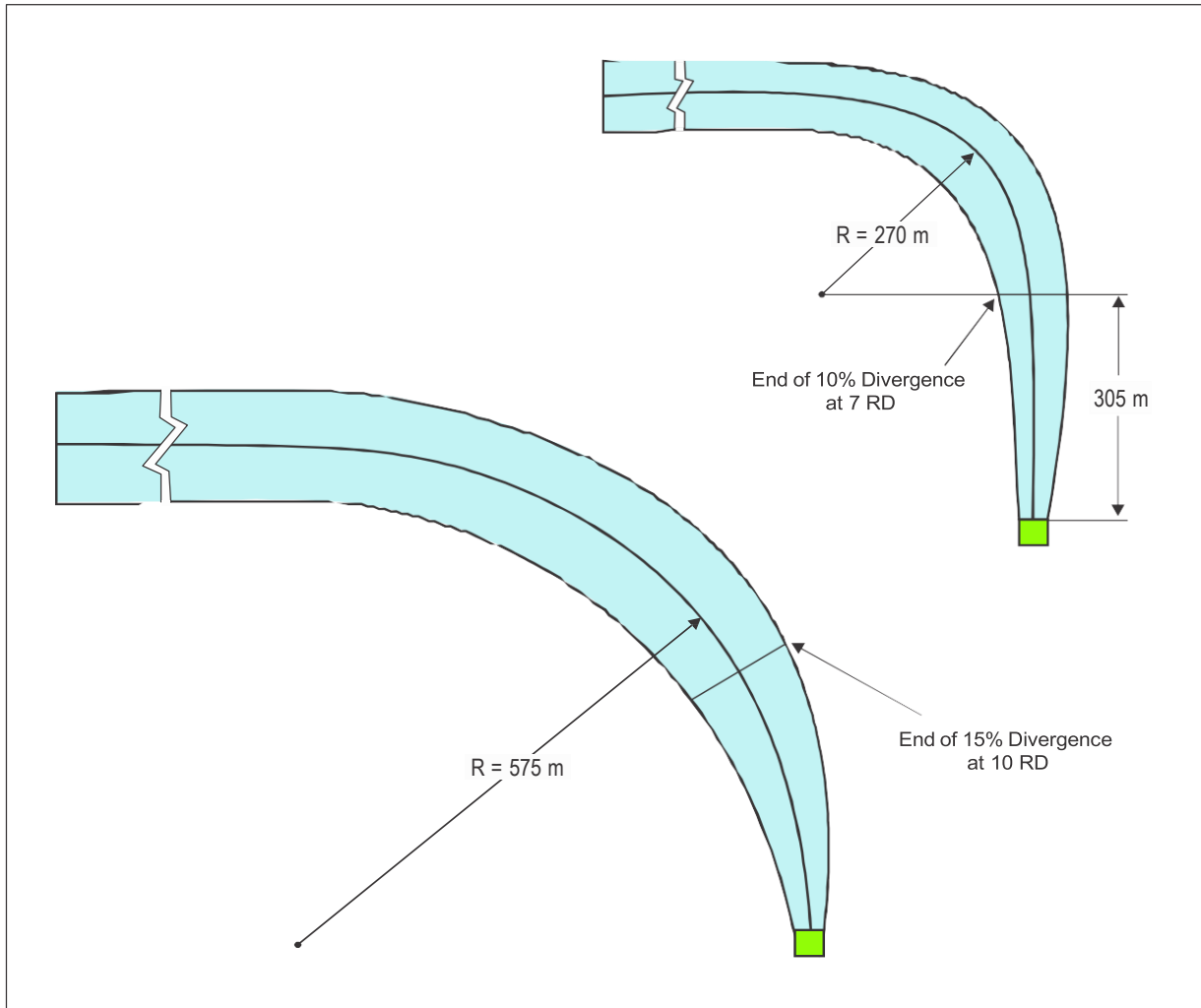

Figure 4-1. Curved approach and take-off climb surface for all FATOs

4.1.6 Where a curved portion of an approach surface is provided, the sum of the radius of arc defining the centre line of the approach surface and the length of the straight portion originating at the inner edge shall not be less than 575 m.

4.1.7 Any variation in the direction of the centre line of an approach surface shall be designed so as not to necessitate a turn radius less than 270 m.

Transitional surface

4.1.8 [Description. A complex surface along the side of the safety area and helicopter clearway, when provided, and part of the side of the approach or take-off climb surface, that slopes upwards and outwards to a predetermined height.]

4.1.9 Characteristics. The limits of a transitional surface shall comprise:

- (a) [a lower edge beginning at a point on the side of the approach or take-off climb surface at a specified height extending down the side of the approach or take-off climb surface to the inner edge and from there along the length of the side of the helicopter clearway, where provided, and safety area parallel to the centre line of the FATO; and
- (b) an upper edge located at;



- (1) 45 m (150 ft) above the FATO; or
- (2) when vertical procedures are being utilized; 15 m (50 ft) above the elevation of the upper edge of the ascent/descent surface.]

4.1.10 The elevation of a point on the lower edge shall be:

- (a) [along the side of the approach or take-off climb surface — equal to the elevation of the approach or take-off climb surface at that point; then;
- (b) if provided, along the helicopter clearway – equal to the elevation of the helicopter clearway; and
- (c) along the safety area — equal to the elevation of the FATO.]

4.1.11 The slope of the transitional surface shall be measured in a vertical plane at right angles to the centre line of the FATO.

Take-off climb surface

4.1.12 *Description.* [An inclined plane, a combination of planes or, when a turn or turns are involved, a complex surface sloping upwards from the end of the safety area, or of the helicopter clearway, when provided, and centred on a line passing through the centre of the FATO.]

4.1.13 *Characteristics.* The limits of a take-off climb surface shall comprise:

- (a) [an inner edge horizontal perpendicular to the centre line of the take-off climb surface, with a minimum width of the width/diameter of;
 - (1) when located at the outer edge of the safety area or helicopter clearway, the FATO plus the safety area; or
 - (2) when located at the outer edge of the elevated helicopter clearway, the elevated helicopter clearway.]
- (b) two side edges originating at the ends of the inner edge and diverging uniformly at a specified rate from the vertical plane containing the centre line of the FATO; and
- (c) [an outer edge horizontal and perpendicular to the centre line of the take-off climb surface at;
 - (1) a height of 152 m (500 ft) above the elevation of the FATO; or
 - (2) when a PinS departure procedure with proceed visually instruction is defined, a specified height above the elevation of the FATO.]

4.1.14 [The elevation of the inner edge shall be;

- (a) the elevation of the FATO at the point on the inner edge that is intersected by the centre line of the take-off climb surface; or
- (b) when located at the outer edge of the helicopter clearway, the elevation of the helicopter clearway.]



- 4.1.15 In the case of a straight take-off climb surface, the slope shall be measured in the vertical plane containing the centre line of the surface.
- 4.1.16 [In the case of a take-off climb surface involving a turn or turns, the surface shall be a complex surface containing the horizontal normals to its centre line and the slope of the centre line shall be the same as that for a straight take-off climb surface.]
- 4.1.17 Where a curved portion of a take-off climb surface, that does not have its inner edge at the outer edge of a clearway, is provided, the sum of the radius of arc defining the centre line of the take-off climb surface and the length of the straight portion originating at the inner edge shall not be less than 575 m.

Note: Helicopter take-off performance is reduced in a turn and as such a straight portion along the take-off climb surface prior to the start of the curve allows for acceleration.]

- 4.1.18 Any variation in the direction of the centre line of a take-off climb surface shall be designed so as not to necessitate a turn of radius less than 270 m.

[Note: For heliports intended to be used by helicopters operated in performance class 2 or 3, it is good practice for the departure paths to be selected so as to permit safe forced landings or one-engine-inoperative landings such that, as a minimum requirement, injury to persons on the ground or water or damage to property are minimized. The most critical helicopter type for which the heliport is intended and the ambient conditions may be factors in determining the suitability of such areas.]

Obstacle-free sector/surface — helidecks

- 4.1.19 *Description.* A complex surface originating at and extending from, a reference point on the edge of the FATO of a helideck. In the case of a TLOF of less than 1 D, the reference point shall be located not less than 0.5 D from the centre of the TLOF.
- 4.1.20 *Characteristics.* An obstacle-free sector/surface shall subtend an arc of specified angle.
- 4.1.21 A helideck obstacle-free sector shall comprise of two components, one above and one below helideck level (See Figure 4-2):
- (a) *Above helideck level.* The surface shall be a horizontal plane level with the elevation of the helideck surface that subtends an arc of at least 210 degrees with the apex located on the periphery of the D circle extending outwards to a distance that will allow for an unobstructed departure path appropriate to the helicopter the helideck is intended to serve.
 - (b) *Below helideck level.* Within the (minimum) 210-degree arc, the surface shall additionally extend downward from the edge of the FATO below the elevation of the helideck to water level for an arc of not less than 180 degrees that passes through the centre of the FATO and outwards to a distance that will allow for safe clearance from the obstacles below the helideck in the event of an engine failure for the type of helicopter the helideck is intended to serve.

Limited obstacle sector/surface — helidecks

- 4.1.22 *Description.* A complex surface originating at the reference point for the obstacle-free sector and extending over the arc not covered by the obstacle-free sector within which the height of obstacles above the level of the TLOF will be prescribed.



4.1.23 *Characteristics.* [A limited obstacle sector shall not subtend an arc greater than 150 degrees. Its dimensions and location shall be as indicated in Figure 4-3 for a 1 D FATO with coincidental TLOF and Figure 4-4 for a 0.83 D TLOF.]

4.2 Obstacle limitation requirements

[Onshore heliports]

4.2.1 The following obstacle limitation surfaces shall be established for a FATO at heliports with a PinS approach or departure procedure with a proceed visually instruction:]

- (a) take-off climb surface;
- (b) approach surface; and
- (c) transitional surfaces.

4.2.2 [The following obstacle limitation surfaces shall be established for a FATO at heliports, other than specified in 4.2.1, including heliports with a PinS approach or departure procedure without a proceed visually instruction:]

- (a) take-off climb surface; and
- (b) approach surface.

4.2.3 [The slopes of the obstacle limitation surfaces shall not be greater than, and their other dimensions not less than, those specified in Table 4-1.

4.2.4 Except for heliports facilitating performance class 1 operations, that have an approach/take-off climb surface with a 4.5 per cent slope design, objects shall be permitted to penetrate the obstacle limitation surface, if the results of an aeronautical study approved by an appropriate authority have reviewed the associated risks and mitigation measures.

Note: The identified objects may limit the heliport operation.

4.2.5 New objects or extensions of existing objects shall not be permitted above any of the surfaces in 4.2.1 and 4.2.2 except when shielded by an existing immovable object.]

4.2.6 Existing objects above any of the surfaces in 4.2.1 and 4.2.2 should, as far as practicable, be removed except when the object is shielded by an existing immovable object.]

4.2.7 [A heliport should have at least two approach and take-off climb surfaces, separated by not less than 135°.



[Table 4-1. Approach and take-off climb slope design categories

Surface and dimensions	Slope design categories		
	A	B	C
Approach and take-off climb surface:			
Length of inner edge	Width of safety area	Width of safety area	Width of safety area
Location of inner edge	Safety area boundary (Helicopter clearway boundary if provided)	Safety area boundary	Safety area boundary
Divergence: (1st and 2nd section)			
Day use only	10%	10%	10%
Night use	15%	15%	15%
First section:			
Length	3 386 m	245 m	1 220 m
Slope	4.5% (1:22.2)	8% (1:12.5)	12.5% (1:8)
Outer width	(b)	N/A	(b)
Second section:			
Length	N/A	830 m	N/A
Slope	N/A	16% (1:6.25)	N/A
Outer width	N/A	(b)	N/A
Total length from inner edge (a)	3 386 m ^c	1 075 m ^c	1 220 m ^c
Transitional surface:			
Slope	50%	50%	50%
Height	(1:2) 45 m ^d	(1:2) 45 m ^d	(1:2) 45 m ^d
<p>a. The approach and take-off climb surface lengths of 3 386 m, 1 075 m and 1 220 m associated with the respective slopes brings the helicopter to 152 m (500 ft) above FATO elevation.</p> <p>b. Seven rotor diameters overall width for day operations or 10 rotor diameters overall width for night operations.</p> <p>c. This length may be reduced if vertical procedures are in place or extended/reduced if the approach or take-off climb surface is extended/reduced to meet the OCS of the PinS approach or departure procedure.</p> <p>d. See 4.1.9 b).</p>			

]

Helidecks

4.2.8 A helideck shall have an obstacle-free sector.

[Note: A helideck may have a LOS (see 4.1.2)]

4.2.9 There shall be no fixed obstacles within the obstacle-free sector above the obstacle-free surface.



- 4.2.10 In the immediate vicinity of the helideck, obstacle protection for helicopters shall be provided below the helideck level. This protection shall extend over an arc of at least 180 degrees with the origin at the centre of the FATO, with a descending gradient having a ratio of one unit horizontally to five units vertically from the edges of the FATO within the 180-degree sector. This descending gradient may be reduced to a ratio of one unit horizontally to three units vertically within the 180-degree sector for multi-engine helicopters operated in performance class 1 or 2. [(See Figure 4-2.)]
- 4.2.11 For a TLOF of 1 D and larger, within the 150-degree limited obstacle surface/sector out to a distance of 0.12 D measured from the point of origin of the limited obstacle sector, objects shall not exceed a height of 25 cm above the TLOF. Beyond that arc, out to an overall distance of a further 0.21 D measured from the end of the first sector, the limited obstacle surface rises at a rate of one unit vertically for each two units horizontally originating at a height 0.05 D above the level of the TLOF. [(See Figure 4-3.)]
- 4.2.12 For a TLOF less than 1 D within the 150-degree limited obstacle surface/sector out to a distance of 0.62 D and commencing from a distance 0.5 D, both measured from the centre of the TLOF, objects shall not exceed a height of 5 cm above the TLOF. Beyond that arc, out to an overall distance of 0.83 D from the centre of the TLOF, the limited obstacle surface rises at a rate of one unit vertically for each two units horizontally originating at a height 0.05 D above the level of the TLOF. [(See Figure 4-4.)]

Shipboard heliports

- 4.2.13 [The specifications in 4.2.16 and 4.2.18 shall be applicable for shipboard heliports completed on or after 1 January 2012.]

Purpose-built heliports located forward or aft

- 4.2.14 When helicopter operating areas are provided in the bow or stern of a ship they shall apply the obstacle criteria for helidecks.

Amidships location — purpose-built and non-purpose-built

- 4.2.15 Forward and aft of a TLOF of 1 D and larger shall be two symmetrically located sectors, each covering an arc of 150 degrees, with their apexes on the periphery of the TLOF. Within the area enclosed by these two sectors, there shall be no objects rising above the level of the TLOF, except those aids essential for the safe operation of a helicopter and then only up to a maximum height of 25 cm.
- 4.2.16 Objects whose function requires them to be located within the TLOF (such as lighting or nets) shall not exceed a height of 2.5 cm. Such objects shall only be present if they do not represent a hazard to helicopters.

[Note: Examples of potential hazards include nets or raised fittings on the deck that might induce dynamic rollover for helicopters equipped with skids.]

- 4.2.17 To provide further protection from obstacles fore and aft of the TLOF, rising surfaces with gradients of one unit vertically to five units horizontally shall extend from the entire length of the edges of the two 150-degree sectors. These surfaces shall extend for a horizontal distance equal to at least 1 D of the largest helicopter the TLOF is intended to serve and shall not be penetrated by any obstacle. [(See Figure 4-5.)]



Non-purpose-built heliports Ship's side location

- 4.2.18 No objects shall be located within the TLOF except those aids essential for the safe operation of a helicopter (such as nets or lighting) and then only up to a maximum height of 2.5 m. Such objects shall only be present if they do not represent a hazard to helicopters.
- 4.2.19 From the fore and aft mid-points of the D circle in two segments outside the circle, limited obstacle areas shall extend to the ship's rail to a fore and aft distance of 1.5 times the fore-to-aft-dimension of the TLOF, located symmetrically about the athwartships bisector of the D circle. Within these areas there shall be no objects rising above a maximum height of 25 cm above the level of the TLOF. [(See Figure 4-6.)] Such objects shall only be present if they do not represent a hazard to helicopters.
- 4.2.20 A limited obstacle sector horizontal surface shall be provided, at least 0.25 D beyond the diameter of the D circle, which shall surround the inboard sides of the TLOF to the fore and aft mid-points of the D circle. The limited obstacle sector shall continue to the ship's rail to a fore and aft distance of 2.0 times the fore-to-aft dimension of the TLOF, located symmetrically about the athwartships bisector of the D circle. Within this sector there shall be no objects rising above a maximum height of 25 cm above the level of the TLOF.

[Note: Any objects located within the areas described in 4.2.19 and 4.2.20 that exceed the height of the TLOF are notified to the helicopter operator using a ship's helicopter landing area plan. For notification purposes, it may be necessary to consider immovable objects beyond the limit of the surface prescribed in 4.2.19, particularly if objects are significantly higher than 25 cm and in close proximity to the boundary of the LOS.]

Winching areas

- 4.2.21 [An area designated for winching on-board ships shall be comprised of a circular clear zone of diameter 5 m and extending from the perimeter of the clear zone, a concentric manoeuvring zone of diameter 2 D. [(See Figure 4-7.)]
- 4.2.22 The manoeuvring zone shall be comprised of two areas:
- (a) the inner manoeuvring zone extending from the perimeter of the clear zone and of a circle of diameter not less than 1.5 D; and
 - (b) the outer manoeuvring zone extending from the perimeter of the inner manoeuvring zone and of a circle of diameter not less than 2 D.
- 4.2.23 Within the clear zone of a designated winching area, no objects shall be located above the level of its surface.
- 4.2.24 Objects located within the inner manoeuvring zone of a designated winching area shall not exceed a height of 3 m.
- 4.2.25 Objects located within the outer manoeuvring zone of a designated winching area shall not exceed a height of 6 m.

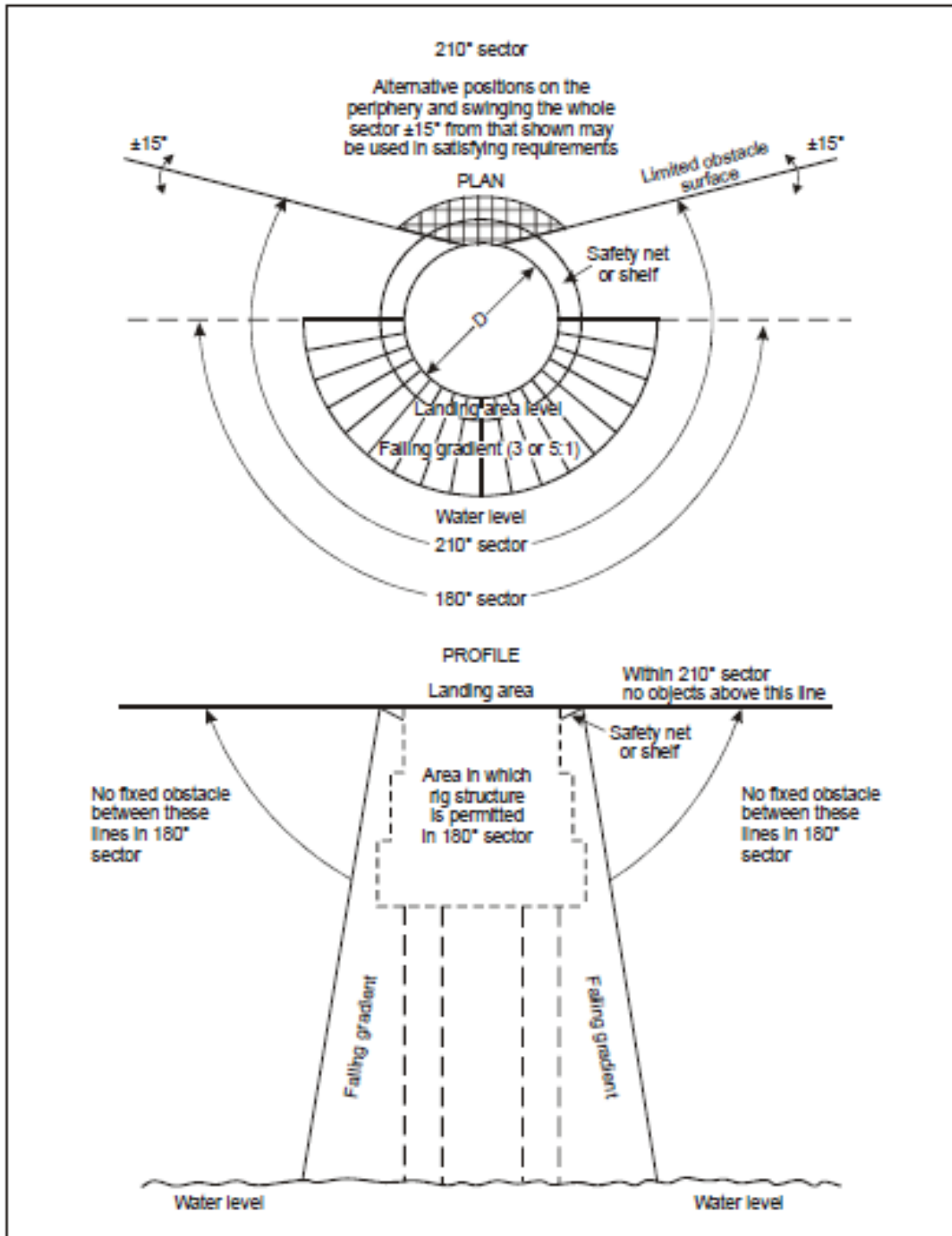

[Figure 4.2. Helideck obstacle-free sector]

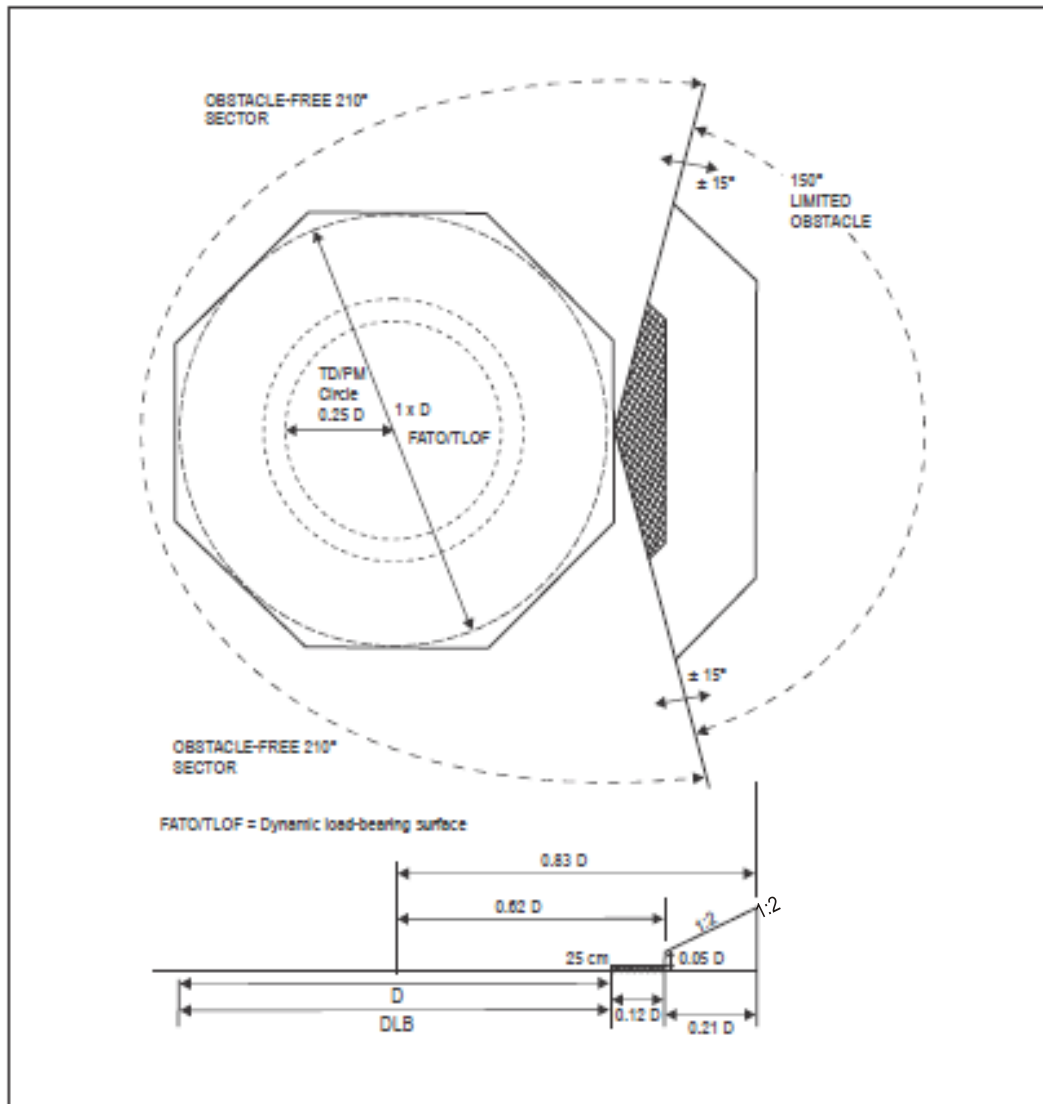

[Figure 4-3. Helideck obstacle limitation sectors and surfaces for a FATO and coincidental TLOF of 1 D and larger]

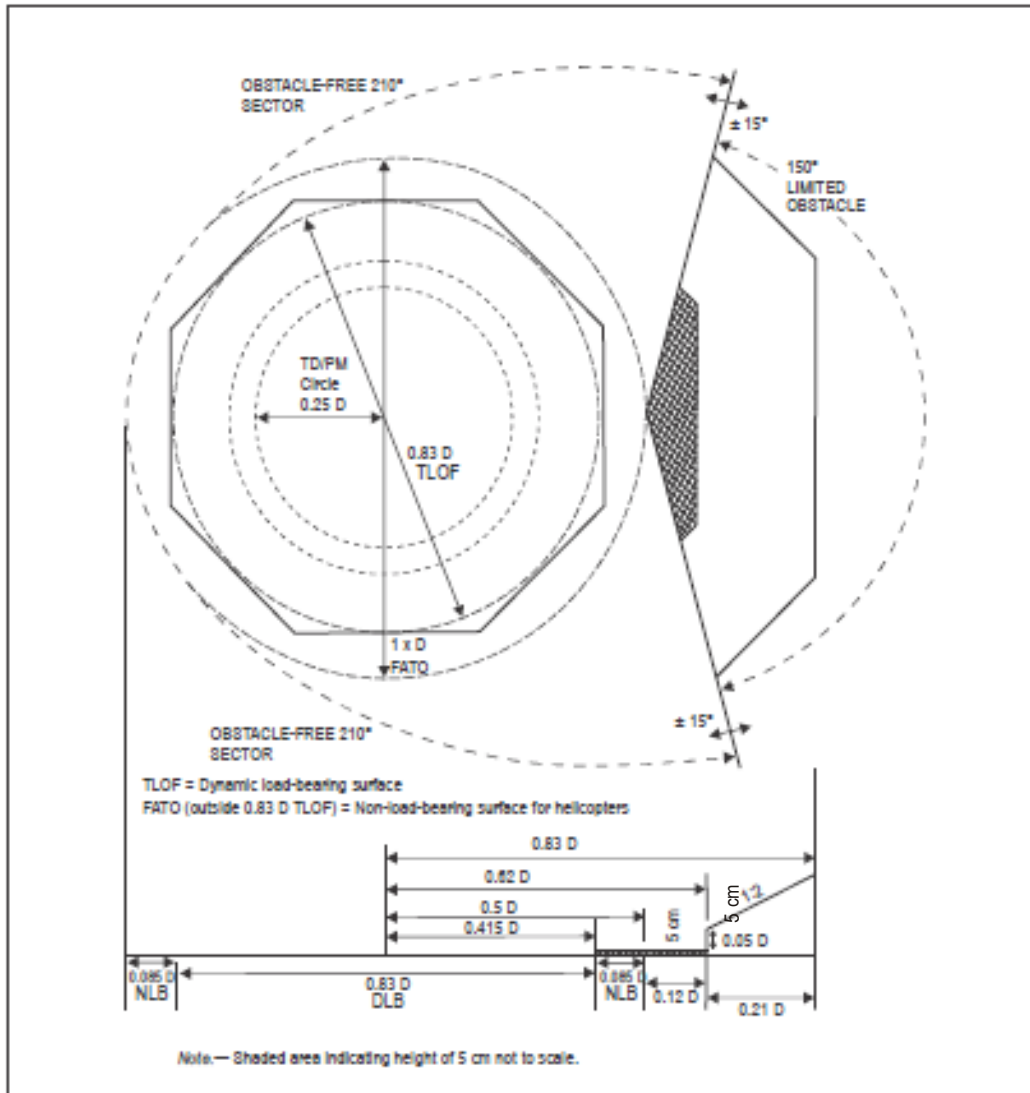

[Figure 4-4. Helideck obstacle limitation sectors and surfaces for a TLOF of 0.83 D and larger]

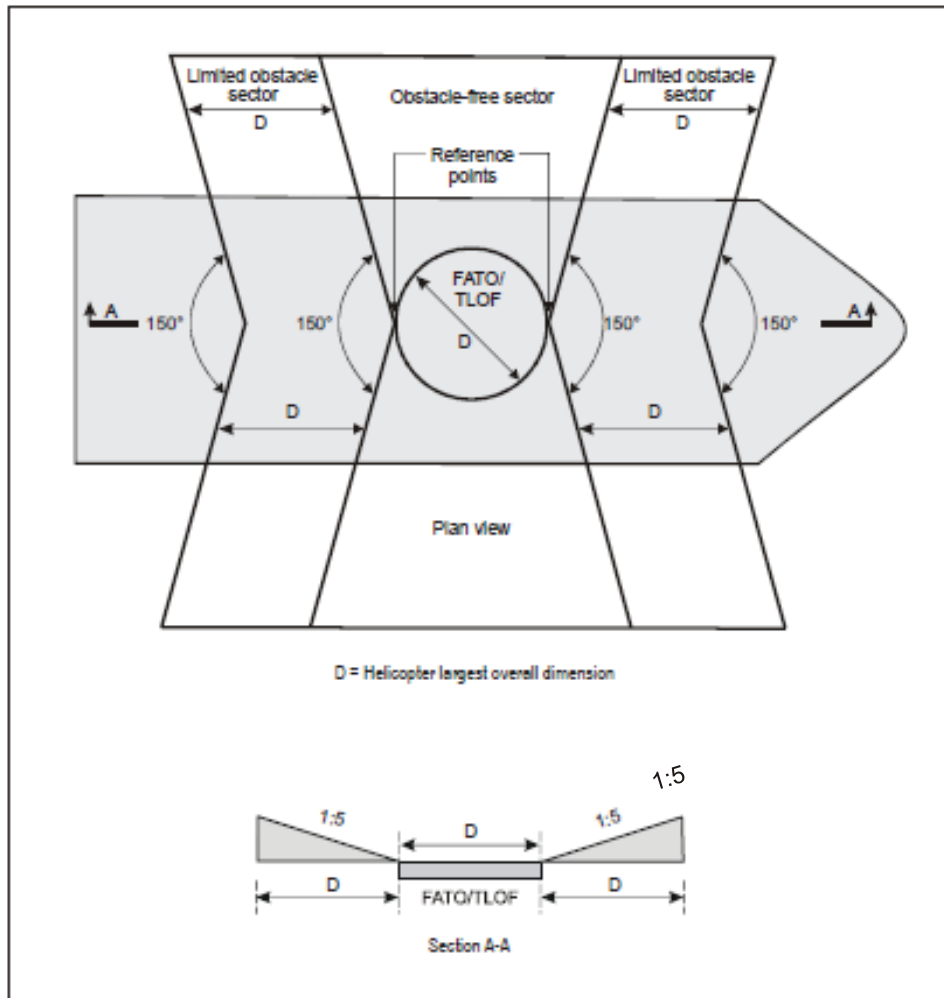

[Figure 4-5. Amidship's location — Shipboard heliport obstacle limitation surfaces]

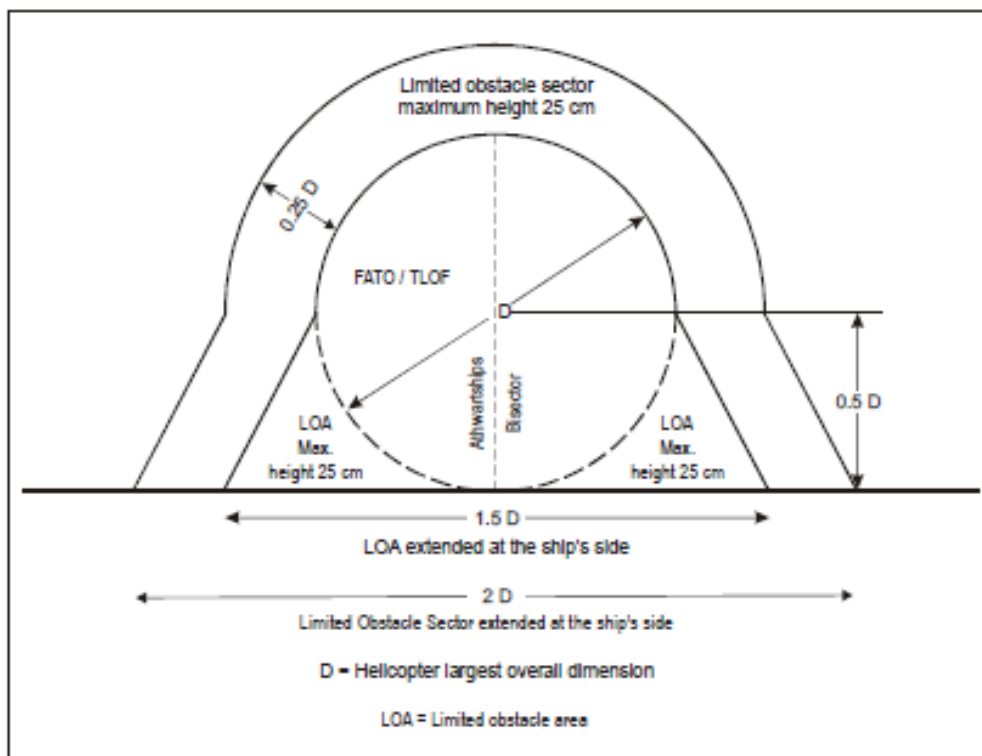

[Figure 4-6 Ships side non-purpose-built heliport obstacle limitation sectors and surfaces]

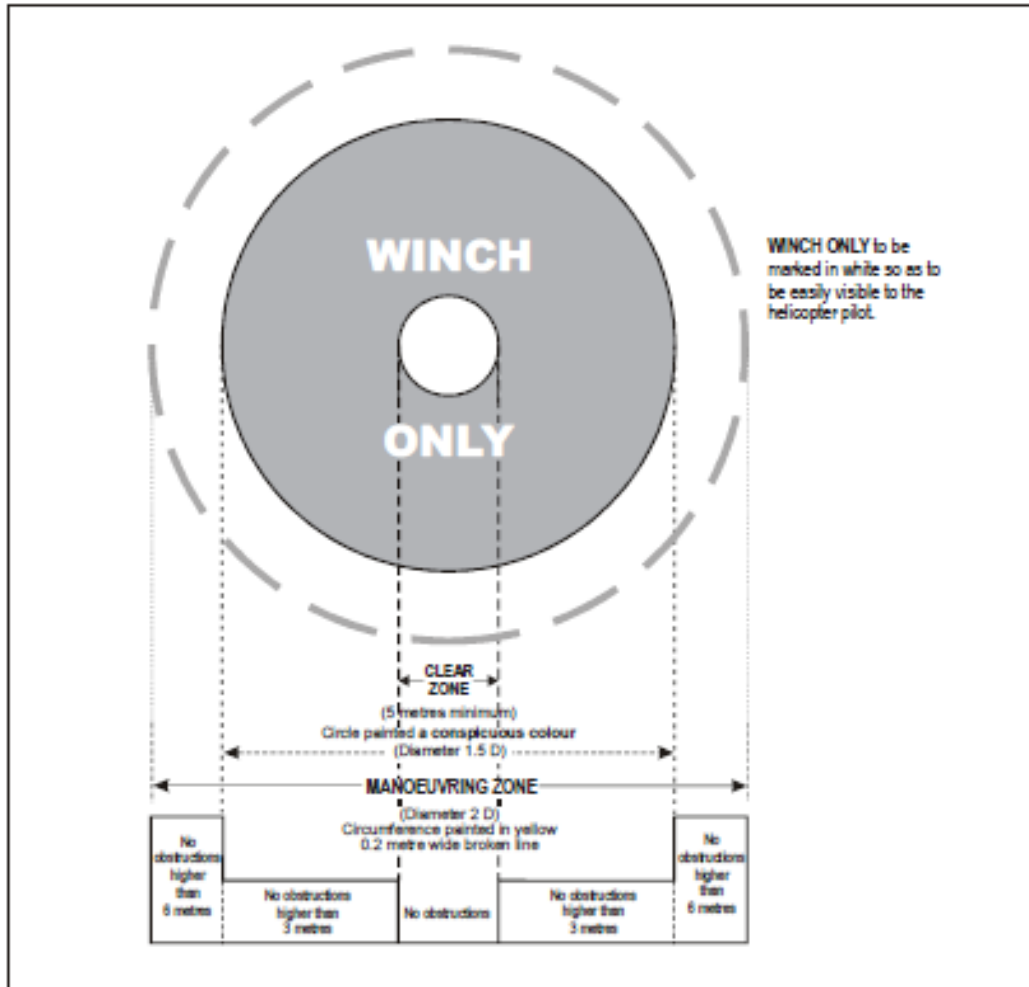

[Figure 4-7 Winching area of ship]



This Page Intentionally Left Blank



CHAPTER 5

VISUAL AIDS

5.1 Wind Direction Indicators

5.1.1 Wind direction indicators

Application

5.1.1.1A heliport shall be equipped with at least one wind direction indicator.

Location

5.1.1.2A wind direction indicator shall be located so as to indicate the wind conditions over the FATO and TLOF and in such a way as to be free from the effects of airflow disturbances caused by nearby objects or rotor downwash. It shall be visible from a helicopter in flight, in a hover or on the movement area.

5.1.1.3 Where a TLOF and/or FATO may be subject to a disturbed airflow, then additional wind direction indicators located close to the area should be provided to indicate the surface wind on the area.

Characteristics

5.1.1.4A wind direction indicator shall be constructed so that it gives a clear indication of the direction of the wind and a general indication of the wind speed.

5.1.1.5 An indicator should be a truncated cone made of lightweight fabric and should have the following minimum dimensions:

	Surface-level Heliports	Elevated heliports and helidecks
<i>Length</i>	<i>2.4 m</i>	<i>1.2 m</i>
<i>Diameter (larger end)</i>	<i>0.6 m</i>	<i>0.3 m</i>
<i>Diameter (smaller end)</i>	<i>0.3 m</i>	<i>0.15 m</i>

5.1.1.6 The colour of the wind direction indicator should be so selected as to make it clearly visible and understandable from a height of at least 200 m (650 ft) above the heliport, having regard to background. Where practicable, a single colour, preferably white or orange, should be used. Where a combination of two colours is required to give adequate conspicuity against changing backgrounds, they should preferably be orange and white, red and white, or black and white, and should be arranged in five alternate bands the first and last band being the darker colour.

5.1.1.7A wind direction indicator at a heliport intended for use at night shall be illuminated.

5.2 Markings and markers

5.2.1 Winching area marking

Note: The objective of the winching area markings is to provide visual cues which assist a helicopter to be positioned over, and retained within, an area from which a passenger or equipment can be lowered or raised.



Application

5.2.1.1 [Winching area markings shall be provided at a designated winching area. (See Figure 4-7.)]

Location

5.2.1.2 Winching area markings shall be located so that their centre(s) coincides with the centre of the clear zone of the winching area. (See Figure 4-7.)

Characteristics

5.2.1.3 Winching area markings shall comprise a winching area clear zone marking and a winching area manoeuvring zone marking.

5.2.1.4 A winching area clear zone marking shall consist of a solid circle of diameter not less than 5 m and of a conspicuous colour.

5.2.1.5 A winching area manoeuvring zone marking shall consist of a broken circle line of 30 cm in width and of a diameter not less than 2 D and be marked in a conspicuous colour. Within it “WINCH ONLY” shall be marked to be easily visible to the pilot.

5.2.2 Heliport identification marking

Application

5.2.2.1 Heliport identification markings shall be provided at a heliport.

Note 1: The objective of a heliport identification marking is to provide to the pilot an indication of the presence of a heliport and, by its form, likely usage; the preferred direction(s) of approach; or the FATO orientation within the helideck obstacle environment.

Note 2: For other than helidecks, the preferred direction(s) of approach corresponds to the median of the departure/arrival surface(s).

Note 3: For helidecks, the bar of the “H” points to the centre of the Limited Obstacle Sector.

Note 4: If the touchdown/positioning marking is offset on a helideck, the heliport identification marking is established in the centre of the touchdown/positioning marking.

Note 5: On a FATO, which does not contain a TLOF and which is marked with an aiming point marking (see 5.2.78), except for a heliport at a hospital, the heliport identification marking is established in the centre of the aiming point marking as shown in Figures 5-1 and 5-1A.

Location — All FATOs except runway-type FATOs

5.2.2.2 A heliport identification marking shall be located at or near the centre of the FATO.

5.2.2.3 On a FATO which contains a TLOF, a heliport identification marking shall be located in the FATO so the position of it coincides with the centre of the TLOF.



Location — Runway-type FATOs

5.2.2.4 A heliport identification marking shall be located in the FATO and when used in conjunction with FATO designation markings, shall be displayed at each end of the FATO as shown in Figure 5-3.

Characteristics

5.2.2.5 A heliport identification marking, except for a heliport at a hospital, shall consist of a letter H, white in colour. The dimensions of the H marking shall be no less than those shown in Figure 5-4 and where the marking is used for a runway-type FATO, its dimensions shall be increased by a factor of 3 as shown in Figure 5-3.

5.2.2.6 A heliport identification marking for a heliport at a hospital shall consist of a letter H, red in colour, on a white cross made of squares adjacent to each of the sides of a square containing the H as shown in Figures 5-2 and 5-4.

5.2.2.7 A heliport identification marking shall be oriented with the cross arm of the H at right angles to the preferred final approach direction. For a helideck the cross arm shall be on or parallel to the bisector of the obstacle-free sector. For a non-purpose-built shipboard heliport located on a ship’s side, the cross arm shall be parallel with the side of the ship.

5.2.2.8 On a helideck or a shipboard heliport where the D value is 16.0 m or larger, the size of the heliport identification H marking shall have a height of 4 m with an overall width not exceeding 3 m and a stroke width not exceeding 0.75 m. Where the D value is less than 16.0 m, the size of the heliport identification H marking shall have a height of 3 m with an overall width not exceeding 2.25 m and a stroke width not exceeding 0.5 m.

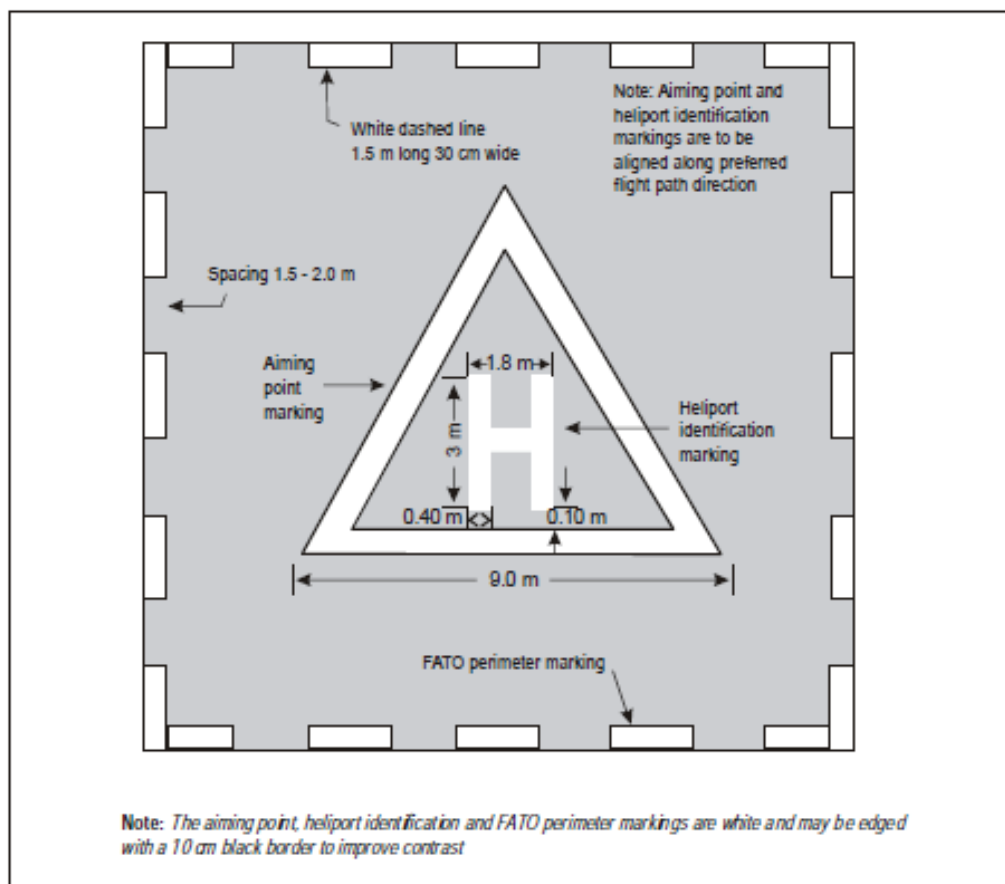

Illustration not to scale

Figure 5-1. Combined heliport identification, aiming point and FATO perimeter marking

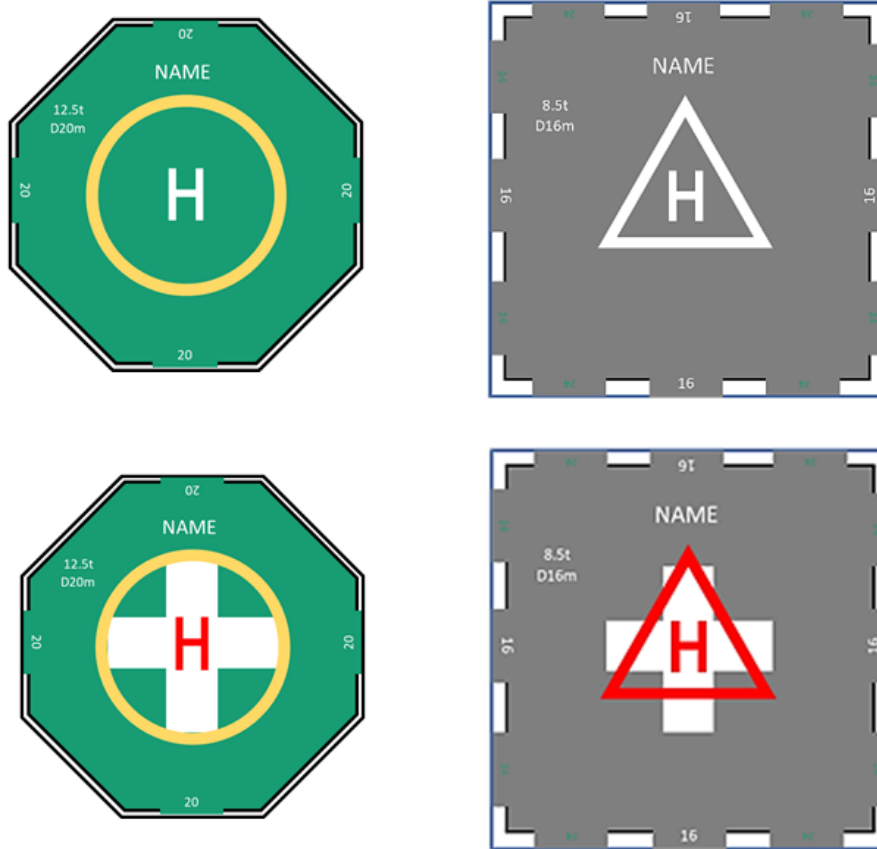

Figure 5-2. Heliport identification markings with TLOF and aiming markings for heliport and hospital heliport

5.2.3 Maximum allowable mass marking

Note 1: The objective of the maximum allowable mass marking is to provide the mass limitation of the heliport such that it is visible to the pilot from the preferred final approach direction.

Note 2: Where States express the maximum allowable mass in pounds, it is not appropriate to suffix with the letter “t” which is used only to indicate metric tonnes.

Application

5.2.3.1A maximum allowable mass marking shall be displayed at an elevated heliport, a helideck and a shipboard heliport.

5.2.3.2A maximum allowable mass marking should be displayed at a surface-level heliport.

Location

5.2.3.3A maximum allowable mass marking should be located within the TLOF or FATO and so arranged as to be readable from the preferred final approach direction.

Characteristics

5.2.3.4A maximum allowable mass marking shall consist of a one, two or three-digit number.

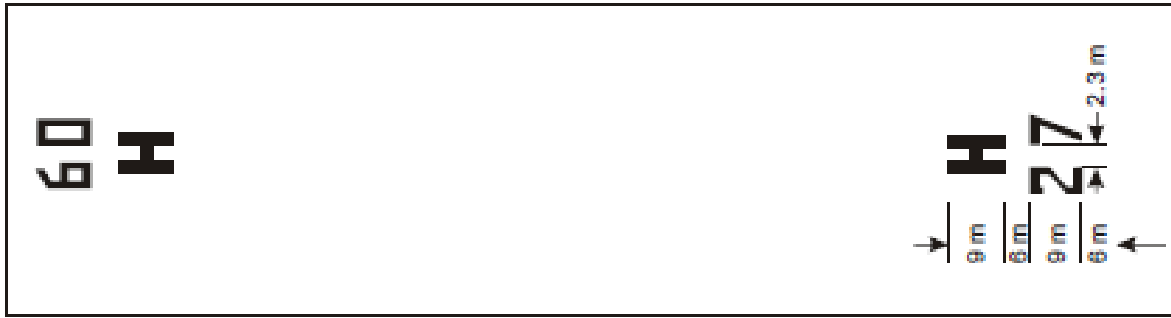

Figure 5-3. FATO designation marking and heliport identification marking for a runway-type FATO

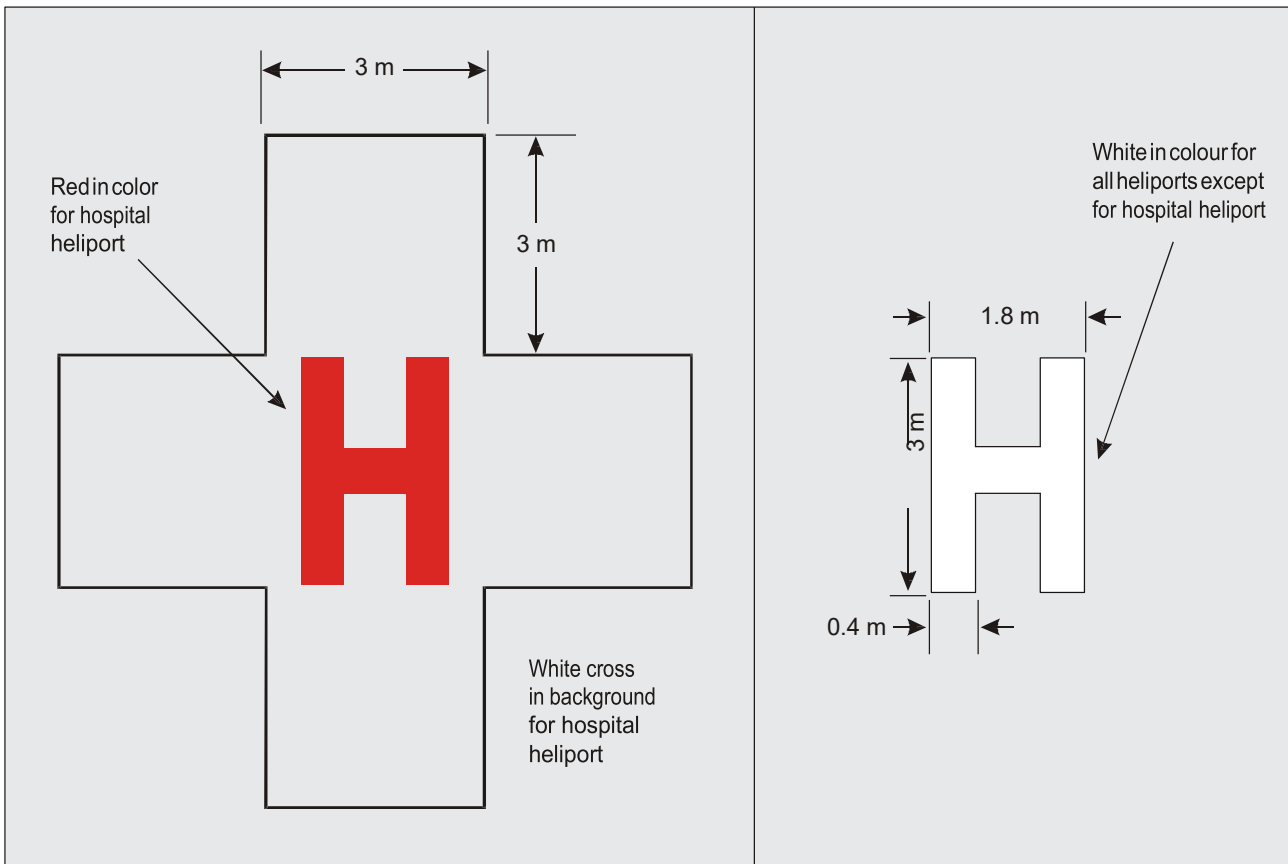

Figure 5-4. Hospital heliport identification and heliport identification marking

5.2.3.5 The maximum allowable mass shall be expressed in tonnes (1 000 kg) rounded down to the nearest 1 000 kg followed by a letter “t”. Where States use mass in pounds, the maximum allowable mass marking shall indicate the allowable helicopter mass in thousands of pounds rounded down to the nearest 1 000 lbs.

5.2.3.6 The maximum allowable mass should be expressed to the nearest 100 kg. The marking should be presented to one decimal place and rounded to the nearest 100 kg followed by the letter “t”. Where States use mass in pounds, the maximum allowable mass marking should indicate the allowable helicopter mass in hundreds of pounds rounded to the nearest 100 lb.

5.2.3.7 When the maximum allowable mass is expressed to 100 kg, the decimal place should be preceded with a decimal point marked with a 30 cm square.



All FATOs except runway-type FATOs

5.2.3.8 The numbers and the letter of the marking shall have a colour contrasting with the background and should be in the form and proportion shown in Figure 5-5 for a D-value of more than 30 m. For a D-value between 15 m to 30 m the height of the numbers and the letter of the marking should be a minimum of 90 cm, and for a D-value of less than 15 m the height of the numbers and the letter of the marking shall be a minimum of 60 cm, each with a proportional reduction in width and thickness.

Runway-type FATOs

5.2.3.9 The numbers and the letter of the marking shall have a colour contrasting with the background and should be in the form and proportion shown in Figure 5-5.

5.2.4 D-value marking

Note: The objective of the D-value marking is to provide to the pilot the “D” of the largest helicopter that can be accommodated on the heliport. This value may differ in size from the FATO and the TLOF provided in compliance with Chapter 3.

Application

All FATOs except runway-type FATOs

5.2.4.1 The D-value marking shall be displayed at a helideck and at a shipboard heliport.

Runway-type FATOs

5.2.4.2 The D-value marking shall be displayed at surface-level and elevated heliports.

Location

5.2.4.3 A D-value marking shall be located within the TLOF or FATO and so arranged as to be readable from the preferred final approach direction.

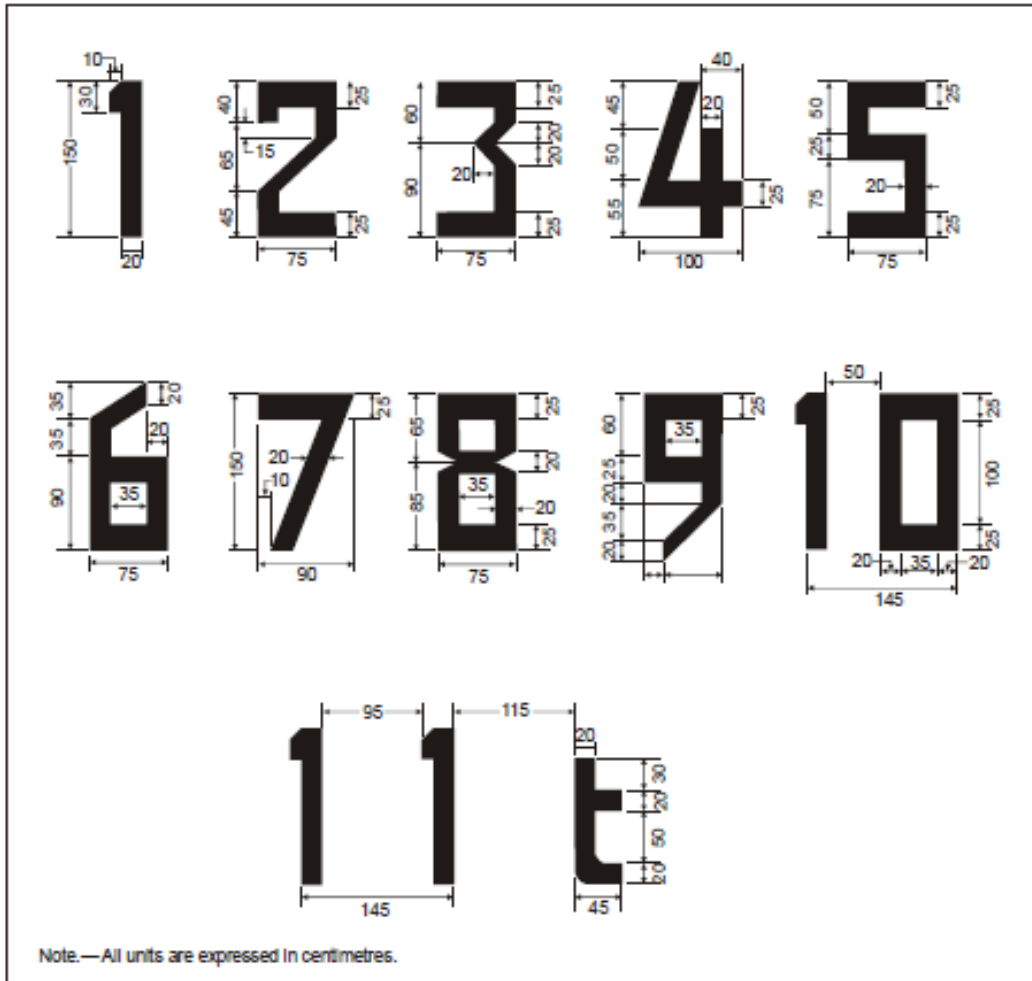

Figure 5-5. Form and proportions of numbers and letters

5.2.4.4 Where there is more than one approach direction, additional D-value markings shall be provided such that at least one D-value marking is readable from the final approach directions. For a non-purpose-built heliport located on a ship’s side, D-value markings shall be provided on the perimeter of the D circle at the 2 o’clock, 10 o’clock and 12 o’clock positions when viewed from the side of the ship facing towards the centre line.

Characteristics

5.2.4.5 The D-value marking shall be white. The D-value marking shall be rounded to the nearest whole metre or foot with 0.5 rounded down.

5.2.4.6 The numbers of the marking shall have a colour contrasting with the background and shall be in the form and proportion shown in Figure 5-5 for a D-value of more than 30 m. For a D-value with a dimension of between 15 m to 30 m the height of the numbers of the marking shall be a minimum of 90 cm, and for a D-value of less than 15 m the height of the numbers of the marking shall be a minimum of 60 cm, each with a proportional reduction in width and thickness.

5.2.5 Final approach and take-off area perimeter marking or markers for surface-level heliports

Note: The objective of final approach and take-off area perimeter marking, or markers, is to provide to the pilot, where the perimeter of the FATO is not self-evident, an indication of the area that is free of obstacles and in which intended procedures, or permitted manoeuvring, may take place.



Application

5.2.5.1 FATO perimeter marking or markers shall be provided at a surface-level heliport where the extent of a FATO with a solid surface is not self-evident.

Location

5.2.5.2 The FATO perimeter marking or markers shall be located on the edge of the FATO.

Characteristics — Runway-type FATOs

5.2.5.3 The perimeter of the FATO shall be defined with markings or markers spaced at equal intervals of not more than 50 m with at least three markings or markers on each side including a marking or marker at each corner.

5.2.5.4 A FATO perimeter marking shall be a rectangular stripe with a length of 9 m or one-fifth of the side of the FATO which it defines and a width of 1 m.

5.2.5.5 FATO perimeter markings shall be white.

5.2.5.6 A FATO perimeter marker shall have dimensional characteristics as shown in Figure 5-6.

5.2.5.7 FATO perimeter markers shall be of colour(s) that contrast effectively against the operating background.

5.2.5.8 FATO perimeter markers should be a single colour, orange or red, or two contrasting colours, orange and white or, alternatively, red and white shall be used except where such colours would merge with the background.

Characteristics — All FATOs except runway-type FATOs

5.2.5.9 For an unpaved FATO the perimeter shall be defined with flush in-ground markers. The FATO perimeter markers shall be 30 cm in width, 1.5 m in length, and with end-to-end spacing of not less than 1.5 m and not more than 2 m. The corners of a square or rectangular FATO shall be defined.

5.2.5.10 For a paved FATO the perimeter shall be defined with a dashed line. The FATO perimeter marking segments shall be 30 cm in width, 1.5 m in length, and with end-to-end spacing of not less than 1.5 m and not more than 2 m. The corners of the square or rectangular FATO shall be defined.

5.2.5.11 FATO perimeter markings and flush in-ground markers shall be white.

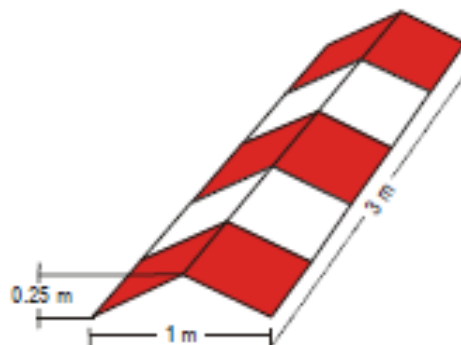

Figure 5-6. Runway-type FATO edge marker



5.2.6 Final approach and take-off area designation markings for runway-type FATOs

Note: The objective of final approach and take-off area designation markings for runway-type FATOs is to provide to the pilot an indication of the magnetic heading of the runway.

Application

5.2.6.1 A FATO designation marking shall be provided at a heliport where it is necessary to designate the FATO to the pilot.

Location

5.2.6.2 A FATO designation marking shall be located at the beginning of the FATO as shown in Figure 5-3.

Characteristics

5.2.6.3 A FATO designation marking shall consist of a two-digit number. The two-digit number shall be the whole number nearest the one-tenth of the magnetic North when viewed from the direction of approach. When the above rule would give a single digit number, it shall be preceded by a zero. The marking as shown in Figure 5-3, shall be supplemented by the heliport identification marking.

5.2.7 Aiming point marking

Note: The objective of the aiming point marking is to provide a visual cue indicating to the pilot the preferred approach/departure direction; the point to which the helicopter approaches to the hover before positioning to a stand where a touchdown can be made; and that the surface of the FATO is not intended for touchdown.

Application

5.2.7.1 An aiming point marking shall be provided at a heliport where it is necessary for a pilot to make an approach to a particular point above a FATO before proceeding to a TLOF.

Location — Runway-type FATOs

5.2.7.2 The aiming point marking shall be located within the FATO.

Location — All FATOs except runway-type FATOs

5.2.7.3 The aiming point marking shall be located at the centre of the FATO as shown in Figure 5-1.

Characteristics

5.2.7.4 The aiming point marking shall be an equilateral triangle with the bisector of one of the angles aligned with the preferred approach direction. The marking shall consist of continuous lines providing a contrast with the background colour, and the dimensions of the marking shall conform to those shown in Figure 5-7.

5.2.8 Touchdown and lift-off area perimeter marking

Note: The objective of the touchdown and lift-off area perimeter marking is to provide to the pilot an indication of an area that is free of obstacles; has dynamic load bearing; and in which, when positioned in accordance with the TDPM, undercarriage containment is assured.



Application

5.2.8.1 A TLOF perimeter marking shall be displayed on a TLOF located in a FATO at a surface-level heliport if the perimeter of the TLOF is not self-evident.

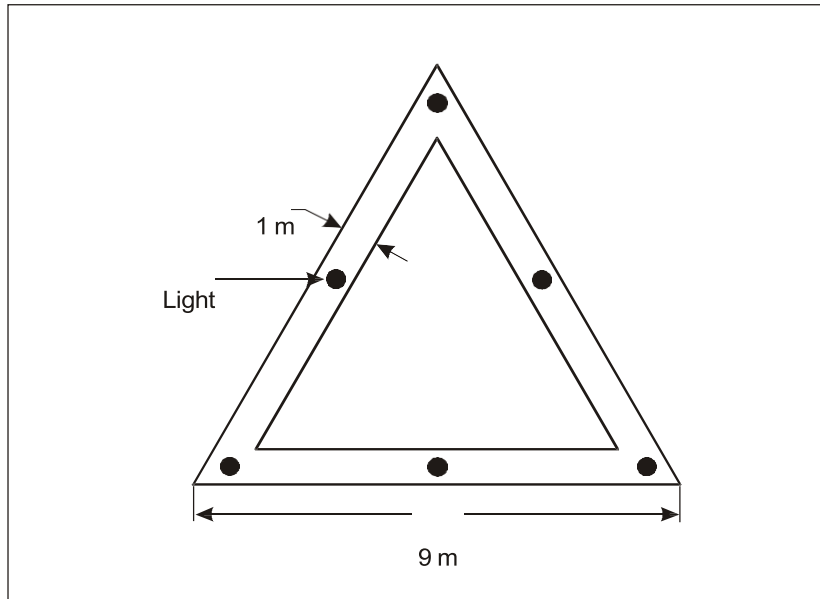

Figure 5-7. Aiming point marking

5.2.8.2 A TLOF perimeter marking shall be displayed on an elevated heliport, a helideck and a shipboard heliport.

Location

5.2.8.3 The TLOF perimeter marking shall be located along the edge of the TLOF.

Characteristics

5.2.8.4 A TLOF perimeter marking shall consist of a continuous white line with a width of at least 30 cm.

5.2.9 Touchdown/positioning marking

Note: The objective of a touchdown/positioning marking (TDPM) is to provide visual cues which permit a helicopter to be placed in a specific position such that, when the pilot’s seat is above the marking, the undercarriage is within the load-bearing area and all parts of the helicopter will be clear of any obstacles by a safe margin.

Application

5.2.9.1 A touchdown/positioning marking shall be provided for a helicopter to touch down or be accurately placed in a specific position.

5.2.9.2 The touchdown/positioning marking shall be:

- (a) when there is no limitation on the direction of touchdown/positioning, a touchdown/positioning circle (TDPC) marking; and
- (b) when there is a limitation on the direction of touchdown/positioning:

- (1) for unidirectional applications, a shoulder line with an associated centreline; or
- (2) for multidirectional applications, a TDPC marking with prohibited landing sector(s) marked.

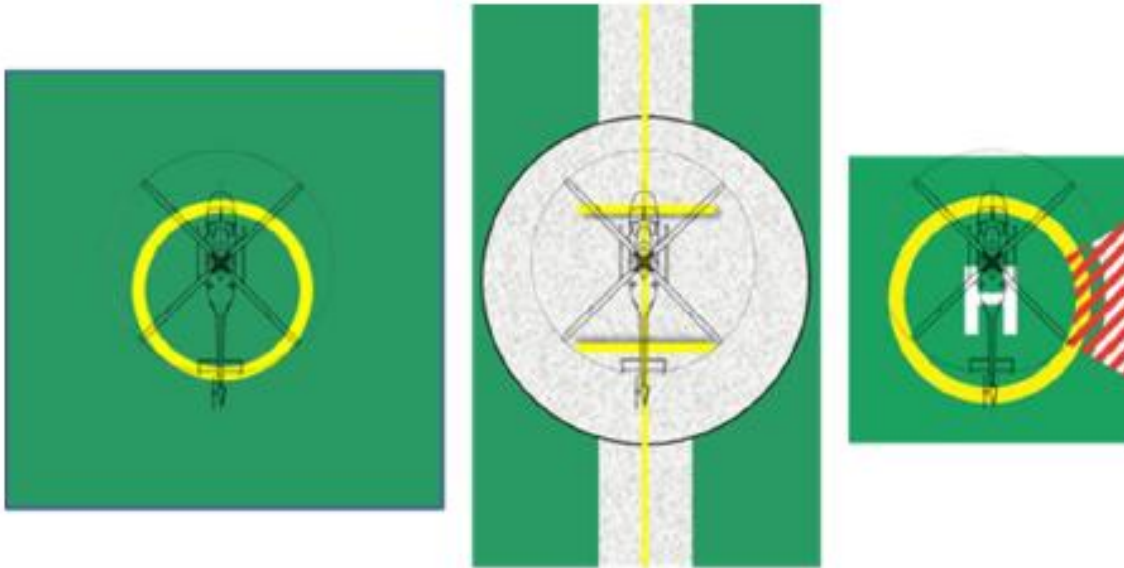

Figure 5-8.

- (Left)** = **multidirectional TDPC with no limitations.**
- (Centre)** = **unidirectional marking shoulder line with associated centreline.**
- (Right)** = **multidirectional TDPC with prohibited landing sector marking**

Note: The prohibited landing sector (PLS) marking, when provided, is not intended to move the helicopter away from objects around the FATO, but to ensure that the tail is not placed in an orientation that might constitute a hazard. This is achieved by having the helicopter nose clear of the hatched markings during the touchdown.

Location

5.2.9.3 The inner edge/inner circumference of the touchdown/positioning marking shall be at a distance of 0.25 D from the centre of the area in which the helicopter is to be positioned.

5.2.9.4 On a helideck, the centre of the TDPC marking shall be located at the centre of the FATO, except that the marking may be offset away from the origin of the obstacle-free sector by no more than 0.1 D where an aeronautical study indicates such offsetting is necessary and would not impair safety.

5.2.9.5 Prohibited landing sector markings, when provided, shall be located on the touchdown/positioning marking, within the relevant headings, and extend to the inner edge of the TLOF perimeter marking.

Characteristics

5.2.9.6 The inner diameter of the TDPC shall be 0.5 D of the largest helicopter the area is intended to serve.



5.2.9.7 A touchdown/positioning marking shall have a line width of at least 0.5 m. For a helideck and a purpose-built shipboard heliport, the line width shall be at least 1 m.

5.2.9.8 The length of a shoulder line shall be 0.5D of the largest helicopter the area is intended to serve.

5.2.9.9 The prohibited landing sector markings, when provided, shall be indicated by white and red hatched markings as shown in Figure 5-8.

5.2.9.10 The TDPM shall take precedent when used in conjunction with other markings on the TLOF except for the prohibited landing sector marking.

5.2.10 Heliport name marking

Note: The objective of a heliport name marking is to provide to the pilot a means of identifying a heliport which can be seen, and read, from all directions of approach.

Application

5.2.10.1 A heliport name marking shall be provided at a heliport and helideck where there is insufficient alternative means of visual identification.

Location

5.2.10.2 Where a limited obstacle sector (LOS) exists on a helideck the marking shall be located on that side of the 'heliport identification marking'. For a non-purpose-built heliport located on a ship's side the marking shall be located on the inboard side of the heliport identification marking in the area between the TLOF perimeter marking and the boundary of the LOS.

Characteristics

5.2.10.3 A heliport name marking shall consist of the name or the alphanumeric designator of the heliport as used in the radio (R/T) communications.

5.2.10.4 A heliport name marking intended for use at night or during conditions of poor visibility should be illuminated, either internally or externally.

Runway-type FATOs

5.2.10.5 The characters of the marking shall be not less than 3 m in height.

All FATOs except runway-type FATOs.

5.2.10.6 The characters of the marking shall be not less than 1.5 m in height at surface-level heliports and not less than 1.2 m on elevated heliports, helidecks and shipboard heliports. The colour of the marking shall contrast with the background and preferably be white.

5.2.11 Helideck obstacle-free sector (chevron) marking

Note: The objective of the helideck obstacle-free sector (chevron) marking is to indicate the direction and limits of a sector that is free of obstacles above the level of the helideck for the preferred approach and departure directions

**Application**

- 5.2.11.1 A helideck with adjacent obstacles that penetrate above the level of the helideck shall have an obstacle-free sector marking.

Location

- 5.2.11.2 A helideck obstacle-free sector marking shall be located, where practicable, at a distance from the centre of the TLOF equal to the radius of the largest circle that can be drawn in the TLOF or 0.5 D, whichever is greater.

Note: Where the Point of Origin is outside the TLOF, and it is not practicable to physically paint the chevron, the chevron is relocated to the TLOF perimeter on the bisector of the OFS. In this case, the distance and direction of displacement, along with the attention getting "WARNING DISPLACED CHEVRON", with the distance and direction of displacement, is marked in a box beneath the chevron in black characters not less than 10 cm high.

Characteristics

- 5.2.11.3 The helideck obstacle-free sector marking shall indicate the location of the obstacle-free sector and the directions of the limits of the sector.
- 5.2.11.4 The height of the chevron shall not be less than 30 cm.
- 5.2.11.5 The chevron shall be marked in a conspicuous colour.
- 5.2.11.6 The colour of the chevron shall be black.

5.2.12 Helideck and shipboard heliport surface marking

Note: The objective of the helideck and shipboard heliport surface marking is to provide, by colour and conspicuity, the location of the TLOF on a helideck or shipboard heliport.

Application

- 5.2.12.1 A surface marking shall be provided to assist the pilot to identify the location of the helideck or shipboard heliport during an approach by day.

Location

- 5.2.12.2 A surface marking shall be applied to the dynamic load bearing area bounded by the TLOF perimeter marking.

Characteristics

- 5.2.12.3 The helideck or shipboard heliport surface bounded by the TLOF perimeter marking shall be of dark green using a high friction coating.

Note: Where the application of a surface coating may have a degrading effect on friction qualities the surface might not be painted. In such cases the best operating practice to enhance the conspicuity of markings is to outline deck markings with a contrasting colour.



5.2.13 Helicopter taxiway markings and markers

Note 1: The objective of helicopter taxiway markings and markers is, without being a hazard to the helicopter, to provide to the pilot by day and, if necessary, by night, visual cues to guide movement along the taxiway.

Note 2: The specifications for taxi-holding position markings in CAR AGA 1 para 5.2.10 are equally applicable to taxiways intended for ground taxiing of helicopters.

Note 3: Ground taxi-routes and air taxi-routes over a taxiway are not required to be marked.

Note 4: Unless otherwise indicated it may be assumed that a helicopter taxiway is suitable for both ground taxiing and air taxiing of helicopters.

Note 5: Signage may be required on an aerodrome where it is necessary to indicate that a helicopter taxiway is suitable only for the use of helicopters.

Application

5.2.13.1 The centre line of a helicopter taxiway shall be identified with a marking.

5.2.13.2 The edges of a helicopter taxiway, if not self-evident, shall be identified with markers or markings.

Location

5.2.13.3 Helicopter taxiway markings shall be along the centre line and, if required, along the edges of a helicopter ground taxiway.

5.2.13.4 Helicopter taxiway edge markers shall be located at a distance of 0.5 m to 3 m beyond the edge of the helicopter ground taxiway.

5.2.13.5 Helicopter taxiway edge markers, where provided, shall be spaced at intervals of not more than 15 m on each side of straight sections and 7.5 m on each side of curved sections with a minimum of four equally spaced markers per section.

Characteristics

5.2.13.6 On a paved taxiway a helicopter taxiway centre line marking shall be a continuous yellow line 15 cm in width.

5.2.13.7 On an unpaved taxiway that will not accommodate painted markings, a helicopter taxiway centre line shall be marked with flush in-ground 15 cm wide and approximately 1.5 m in length yellow markers, spaced at intervals of not more than 30 m on straight sections and not more than 15 m on curves, with a minimum of four equally spaced markers per section.

5.2.13.8 Helicopter taxiway edge markings shall be a continuous double yellow line, each 15 cm in width, and spaced 15 cm apart (nearest edge to nearest edge).

5.2.13.9 A helicopter taxiway edge marker shall be frangible to the wheeled undercarriage of a helicopter.



5.2.13.10 A helicopter taxiway edge marker shall not exceed a plane originating at a height of 25 cm above the plane of the helicopter taxiway, at a distance of 0.5 m from the edge of the helicopter taxiway and sloping upwards and outwards at a gradient of 5 per cent to a distance of 3 m beyond the edge of the helicopter taxiway.

5.2.13.11 A helicopter taxiway edge marker shall be blue.

5.2.13.12 If the helicopter taxiway is to be used at night, the edge markers shall be internally illuminated or retro-reflective.

5.2.14 Helicopter air taxi-route markings and markers

Note: The objective of helicopter air taxi-route markings and markers is to provide to the pilot by day and, if necessary, by night, visual cues to guide movement along the air taxi-route.

Application

5.2.14.1 The centre line of a helicopter air taxi-route shall be identified with markers or markings.

Location

5.2.14.2 [A helicopter air taxi-route centre line marking or markers shall be located along the centre line of the helicopter air taxiway.]

Characteristics

5.2.14.3 A helicopter air taxi-route centre line, when on a paved surface, shall be marked with a continuous yellow line 15 cm in width.

5.2.14.4 [A helicopter air taxi-route centre line, that will not accommodate painted markings, shall be marked with markers, spaced at intervals of not more than 30 m on straight sections and not more than 15 m on curves, with a minimum of four equally spaced markers per section.]

5.2.14.5 If the helicopter air taxi-route is to be used at night, markers shall be either internally illuminated or retro-reflective.

5.2.15 Helicopter stand markings

Note: The objective of the helicopter stand markings is to provide to the pilot a visual indication of an area that is free of obstacles and in which permitted manoeuvring, and all necessary ground functions, may take place; identification, mass and D-value limitations, when required; and, guidance for manoeuvring and positioning of the helicopter within the stand.

Application

5.2.15.1 A helicopter stand perimeter marking shall be provided.

5.2.15.2 A helicopter stand shall be provided with the appropriate TDPM. (See figure 5-8)

5.2.15.3 Alignment lines and lead-in/lead-out lines shall be provided on a helicopter stand.

Note 1: See Figures 3.5 to 3.9 of Chapter 3.



Note 2: Helicopter stand identification markings may be provided where there is a need to identify individual stands.

Note 3: Additional markings relating to stand size may be provided.

Location

5.2.15.4 The TDPM, alignment lines and lead-in/lead-out lines shall be located such that every part of the helicopter can be contained within the helicopter stand during positioning and permitted manoeuvring.

5.2.15.5 Alignment lines and lead-in/lead-out lines shall be located as shown in Figure 5-9.

Characteristics

5.2.15.6 A helicopter stand perimeter marking shall consist of a continuous yellow line and have a line width of 15 cm.

5.2.15.7 The TDPM shall have the characteristics described in section 5.2.9 above.

5.2.15.8 Alignment lines and lead-in/lead-out lines shall be continuous yellow lines and have a width of 15 cm.

5.2.15.9 Curved portions of alignment lines and lead-in/lead-out lines shall have radii appropriate to the most demanding helicopter type the helicopter stand is intended to serve.

5.2.15.10 Stand identification markings shall be marked in a contrasting colour so as to be easily readable.

5.2.15.11

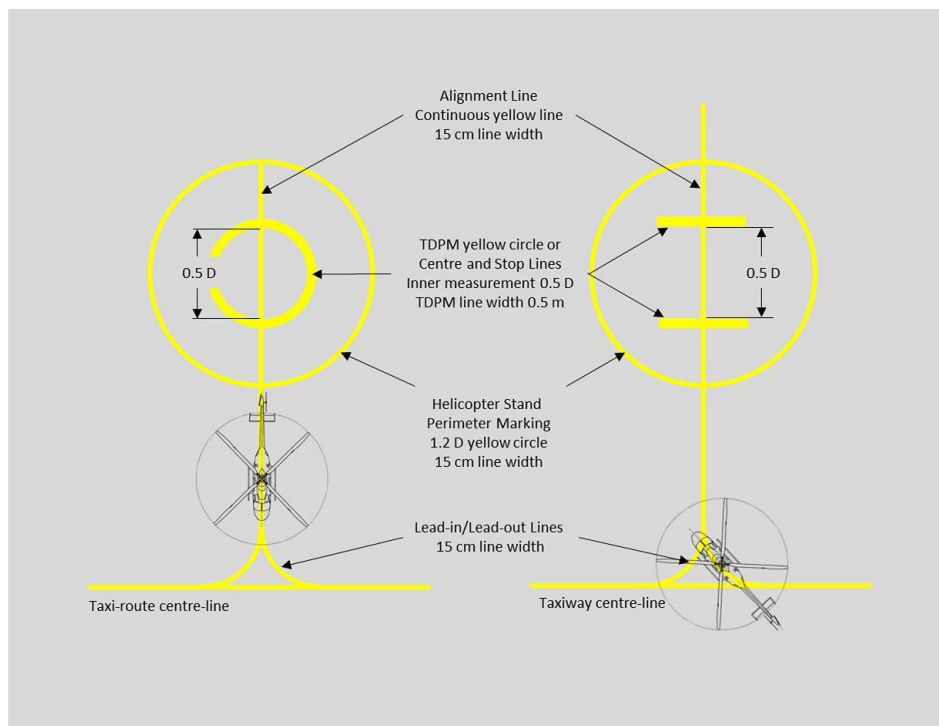

Figure 5-9. Helicopter stand markings



Note 1: Where it is intended that helicopters proceed in one direction only, arrows indicating the direction to be followed may be added as part of the alignment lines.

Note 2: The characteristics of markings related to the stand size and alignment and lead-in/lead-out lines are illustrated in Figure 5-9. Examples of stands and their markings can be seen in Figures 3.5 to 3.9 of Chapter 3.

5.2.16 Flight path alignment guidance marking

Note: The objective of a flight path alignment guidance marking is to provide the pilot with a visual indication of the available approach and/or departure path direction(s)

Application

5.2.16.1 Flight path alignment guidance marking(s) shall be provided at a heliport where it is desirable and practicable to indicate available approach and/or departure path direction(s).

Note: The flight path alignment guidance marking can be combined with a flight path alignment guidance lighting system described in 5.3.4.

Location

5.2.16.2 The flight path alignment guidance marking shall be located in a straight line along the direction of approach and/or departure path on one or more of the TLOF, FATO, safety area or any suitable surface in the immediate vicinity of the FATO or safety area.

Characteristics

5.2.16.3 A flight path alignment guidance marking shall consist of one or more arrows marked on the TLOF, FATO and/or safety area surface as shown in Figure 5-10. The stroke of the arrow(s) shall be 50 cm in width and at least 3 m in length. When combined with a flight path alignment guidance lighting system it shall take the form shown in Figure 5-10 which includes the scheme for marking “heads of the arrows” which are constant regardless of stroke length.

5.2.16.4 The markings shall be in a colour which provides good contrast against the background colour of the surface on which they are marked, preferably white.

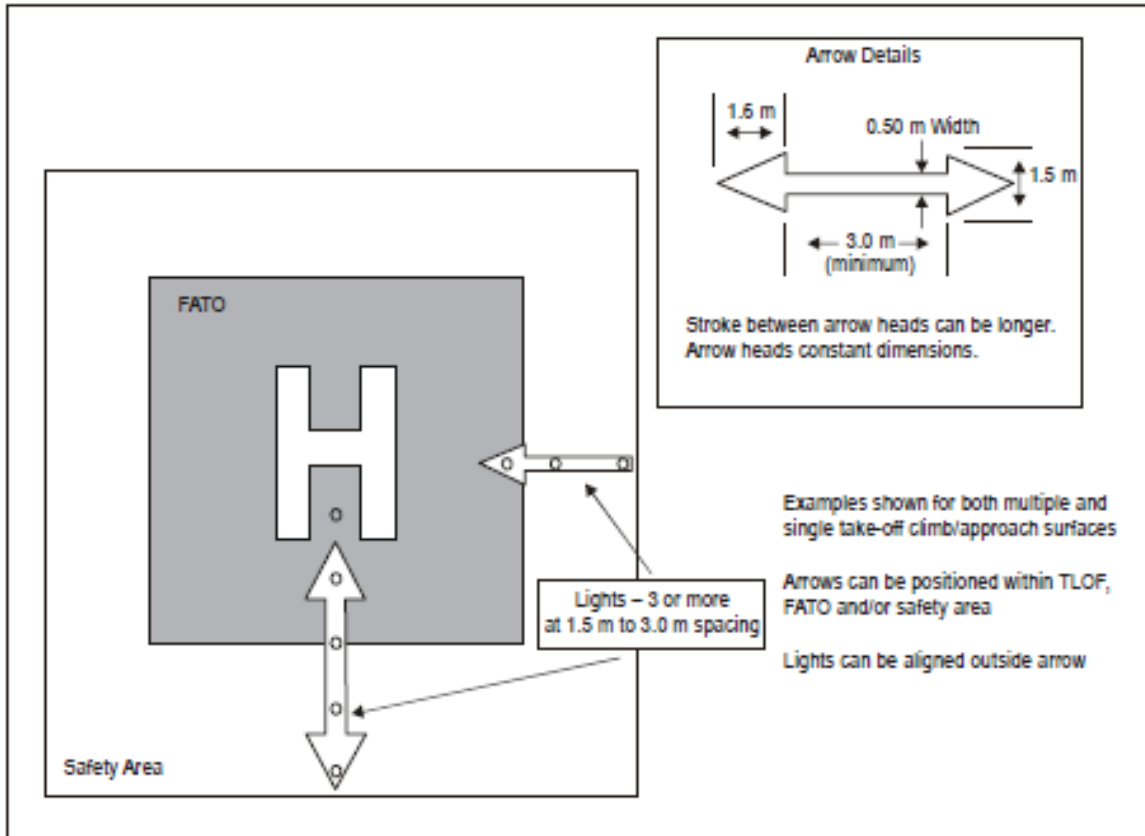

Figure 5-10. Flight path alignment guidance markings and lights

5.3 Lights

5.3.1 General

- (a) In the case of helidecks and heliports located near navigable waters, aeronautical ground lights shall not be sighted as to cause confusion to mariners.
- (b) Extraneous light sources shall be screened or located so as to avoid direct and reflected glare towards helicopters.

Note 1: See Annex 14, Volume I, 5.3.1, concerning specifications on screening of non-aeronautical ground lights, and design of elevated and inset lights.

Note 2: In the case of helidecks and heliports located near navigable waters, consideration needs to be given to ensuring that aeronautical ground lights do not cause confusion to mariners.

Note 3: As helicopters will generally come very close to extraneous light sources, it is particularly important to ensure that, unless such lights are navigation lights exhibited in accordance with international regulations, they are screened or located so as to avoid direct and reflected glare.

Note 4: Systems addressed in sections 5.3.4, 5.3.6, 5.3.7, and 5.3.8 are designed to provide effective lighting cues based on night conditions. Where lights are to be used in conditions other than night (i.e. day or twilight) it may be necessary to increase the intensity of the lighting to maintain effective visual cues by use of a suitable brilliancy control.



Note 5: The specifications for marking and lighting of obstacles included in CAR AGA 1, Chapter 6, are equally applicable to heliports and winching areas.

Note 6: [In cases where operations into a heliport are to be conducted at night with Night Vision Imaging Systems (NVIS), it is important to ensure all heliport lighting are compatible with the NVIS such as through the addition of infrared emitters to the heliport lighting. Where such additional measures are not practicable, helicopter operators using NVIS are to be made aware of it.]

5.3.2 Heliport beacon

[Note: The objective of a heliport beacon is to make a heliport more conspicuous to assist the pilot to locate and identify the heliport at night and/or by day in reduced visibility.]

Application

5.3.2.1 A heliport beacon shall be provided at a heliport where:

- (a) long-range visual guidance is considered necessary and is not provided by other visual means; or
- (b) identification of the heliport is difficult due to surrounding lights.

Location

5.3.2.2 The heliport beacon shall be located on or adjacent to the heliport preferably at an elevated position and so that it does not dazzle a pilot at short range.

Characteristics

5.3.2.3 The heliport beacon shall emit repeated series of equi-spaced short duration white flashes in the format in Figure 5-11.

5.3.2.4 The light from the beacon shall show at all angles of azimuth.

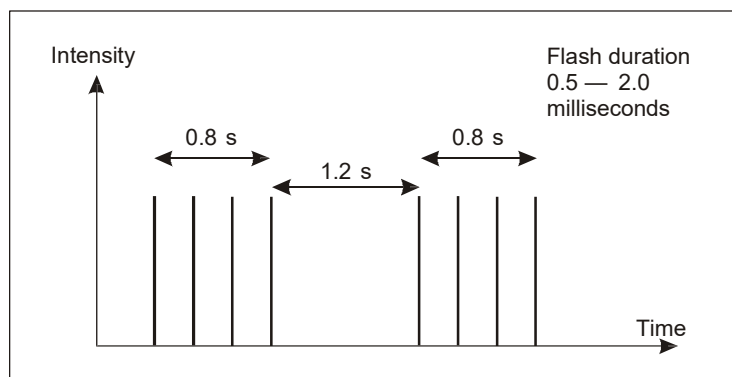

Figure 5-11. Heliport beacon flash characteristics

5.3.2.5 The effective light intensity distribution of each flash shall be as shown in Figure 5-12, Illustration 1.



5.3.3 Approach lighting system

[Note: The objective of an approach lighting system is to allow the helicopter operator, by day and night, to visually identify the heliport and align the helicopter on the centreline of the FATO upon arriving at a prescribed point on the approach flight path.]

Application

5.3.3.1 Where deemed necessary by the Authority an approach lighting system shall be provided at a heliport where it is desirable and practicable to indicate a preferred approach direction.

Location

5.3.3.2 The approach lighting system shall be located in a straight line along the preferred direction of approach.

Characteristics

5.3.3.3 An approach lighting system shall consist of a row of three lights spaced uniformly at 30 m intervals and of a crossbar 18 m in length at a distance of 90 m from the perimeter of the FATO as shown in Figure 5-13. The lights forming the crossbar shall be as nearly as practicable in a horizontal straight line at right angles to, and bisected by, the line of the centre line lights and spaced at 4.5 m intervals. Where there is the need to make the final approach course more conspicuous, additional lights spaced uniformly at 30 m intervals shall be added beyond the crossbar. The lights beyond the crossbar may be steady or sequenced flashing, depending upon the environment.

5.3.3.4 The steady lights shall be omnidirectional white lights.

5.3.3.5 Sequenced flashing lights shall be omnidirectional white lights.

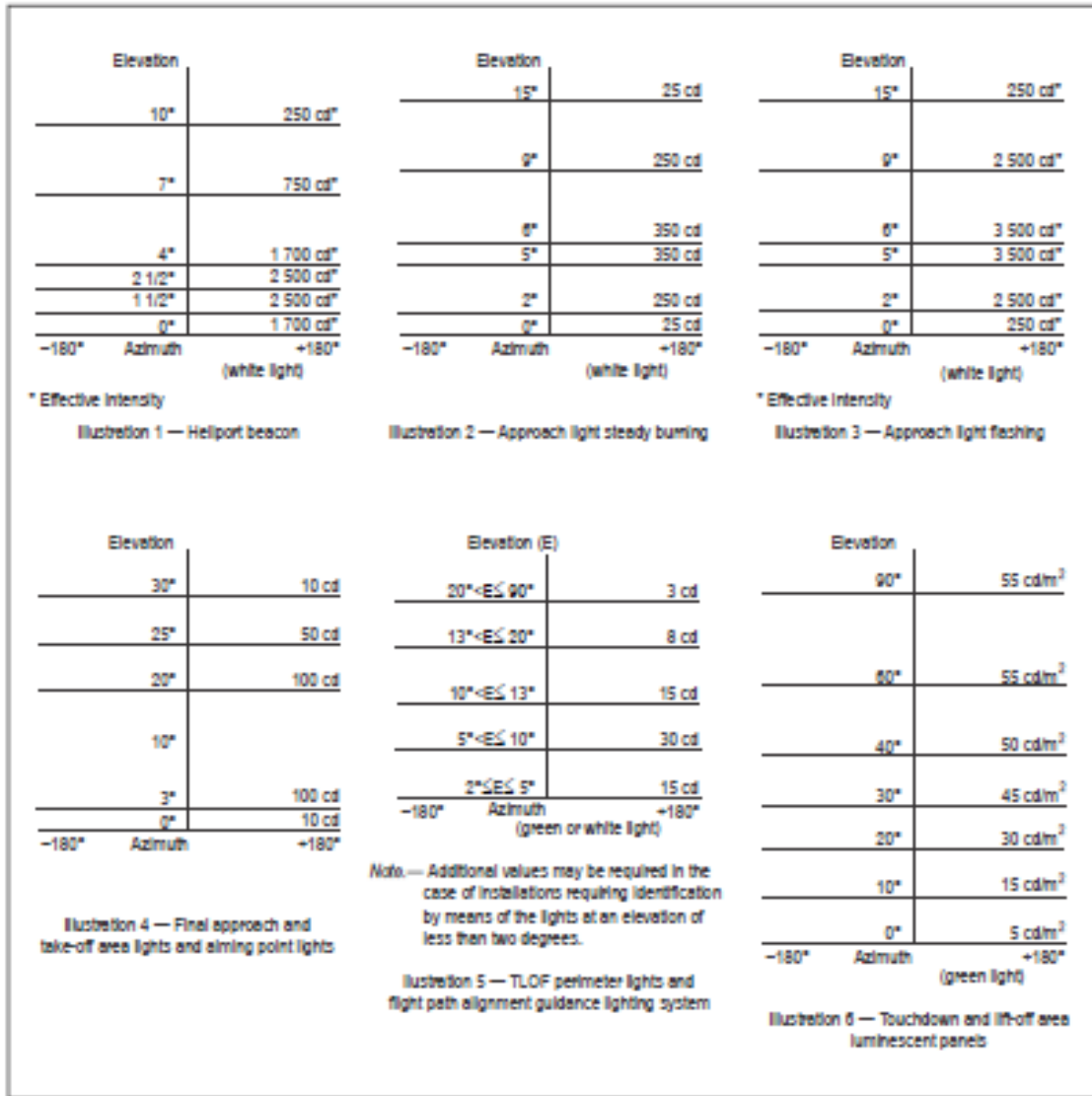

Figure 5-12. Isocandela diagrams

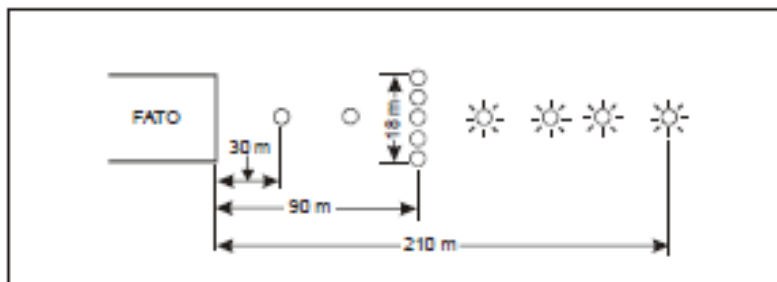

Figure 5-13. Approach lighting system

5.3.3.6 The flashing lights shall have a flash frequency of one per second and their light distribution shall be as shown in Figure 5-12, Illustration 3. The flash sequence shall commence from the outermost light and progress towards the crossbar.

5.3.3.7 A suitable brilliancy control shall be incorporated to allow for adjustment of light intensity to meet the prevailing conditions.

Note: The following intensity settings have been found suitable:



- (a) steady lights — 100 per cent, 30 per cent and 10 per cent; and
- (b) flashing lights — 100 per cent, 10 per cent and 3 per cent.

5.3.4 Flight path alignment guidance lighting system

[Note: The objective of a flight path alignment guidance lighting system is to indicate, by day, night, and in reduced visibility, available approach and/or departure flight path direction(s).]

Application

5.3.4.1 Flight path alignment guidance lighting system(s) shall be provided at a heliport where it is desirable and practicable to indicate available approach and/or departure path direction(s).

Location

5.3.4.2 The flight path alignment guidance lighting system shall be in a straight line along the direction(s) of approach and/or departure path on one or more of the TLOF, FATO, safety area or any suitable surface in the immediate vicinity of the FATO, TLOF or safety area.

5.3.4.3 If combined with a flight path alignment guidance marking, the lights shall be located inside the “arrow” markings.

Characteristics

5.3.4.4 A flight path alignment guidance lighting system shall consist of a row of three or more lights spaced uniformly a total minimum distance of 6 m. Intervals between lights should not be less than 1.5 m and should not exceed 3 m. Where space permits there should be 5 lights. (See Figure 5-10.)

5.3.4.5 The lights shall be steady omnidirectional inset white lights.

5.3.4.6 The distribution of the lights shall be as indicated in Figure 5-12, Illustration 5.

5.3.4.7 A suitable control should be incorporated to allow for adjustment of light intensity to meet the prevailing conditions and to balance the flight path alignment guidance lighting system with other heliport lights and general lighting that may be present around the heliport.

5.3.5 Visual alignment guidance system

Note: The objective of a visual alignment guidance system is to provide conspicuous and discrete cues to assist the pilot to attain, and maintain, a specified approach track to a heliport.

Application

5.3.5.1 A visual alignment guidance system shall be provided to serve the approach to a heliport where one or more of the following conditions exist especially at night:

- (a) obstacle clearance, noise abatement or traffic control procedures require a particular direction to be flown;
- (b) the environment of the heliport provides few visual surface cues; and



- (c) it is physically impracticable to install an approach lighting system.

5.3.6 Visual Approach Slope Indicator

Note: The objective of a visual approach slope indicator is to provide conspicuous and discrete colour cues within a specified elevation and azimuth, to assist the pilot to attain and maintain the approach slope to a desired position within a FATO.

Application

5.3.6.1A Visual Approach Slope Indicator shall be provided to serve the approach to a heliport, whether or not the heliport is served by other visual approach aids or by non-visual aids, where one or more of the following conditions exist especially at night:

- (a) obstacle clearance, noise abatement or traffic control procedures require a particular slope to be flown;
- (b) the environment of the heliport provides few visual surface cues; and
- (c) the characteristics of the helicopter require a stabilized approach.

5.3.7 [Final Approach and Take-Off area perimeter lights for on-shore surface-level heliports

Note: The objective of FATO perimeter lights for onshore surface-level heliports is to provide to the pilot operating at night an indication of the shape, location and extent of the FATO.

Application

5.3.7.1 Where a FATO with a solid surface is established at a surface-level heliport intended for use at night, FATO perimeter lights shall be provided except that they may be omitted where the FATO and the TLOF are nearly coincidental or the extent of the FATO is self-evident.

Location

5.3.7.2 FATO perimeter lights shall be placed along the edges of the FATO. The lights shall be uniformly spaced as follows:]

- (a) for an area in the form of a square or rectangle, at intervals of not more than 50 m with a minimum of four lights on each side including a light at each corner; and
- (b) for any other shaped area, including a circular area, at intervals of not more than 5 m with a minimum of ten lights.

Characteristics

5.3.7.3 [FATO perimeter lights shall be fixed omnidirectional lights showing green or white with variable intensity. Green perimeter lights shall be permitted only when the FATO is a dynamic load-bearing surface.

5.3.7.4 The light distribution of FATO perimeter lights shall be as shown in Figure 5-12, Illustration 4.]



5.3.7.5 The lights shall not exceed a height of 25 cm and should be inset when a light extending above the surface would endanger helicopter operations. Where a FATO is not meant for lift-off or touchdown, the lights shall not exceed a height of 25 cm above ground level.

5.3.8 Aiming point lights

Note: The objective of aiming point lights is to provide a visual cue indicating to the pilot by night the preferred approach/departure direction; the point to which the helicopter approaches to a hover before positioning to a TLOF, where a touchdown can be made; and that the surface of the FATO is not intended for touchdown.

Application

5.3.8.1 Where an aiming point marking is provided at a heliport intended for use at night, aiming point lights shall be provided.

Location

5.3.8.2 Aiming point lights shall be collocated with the aiming point marking.

Characteristics

5.3.8.3 Aiming point lights shall form a pattern of at least six omnidirectional white lights as shown in Figure 5-7. [The lights shall be arranged equidistantly with a light at the apex and at both corners.] The lights shall be inset when a light extending above the surface could endanger helicopter operations.

5.3.8.4 The light distribution of aiming point lights should be as shown in Figure 5-12, Illustration 4.

5.3.9 Touchdown and Lift-off Area (TLOF) lighting system

Note: The objective of a touchdown and lift-off area lighting system is to provide illumination of the TLOF and required elements within. For a TLOF located in a FATO, the objective is to provide discernibility, to the pilot on a final approach, of the TLOF and required elements within; while for a TLOF located on an elevated heliport, shipboard heliport or helideck, the objective is visual acquisition from a defined range and to provide sufficient shape cues to permit an appropriate approach angle to be established.

Application

5.3.9.1 A TLOF lighting system shall be provided at a heliport intended for use at night.

Note: Where a TLOF is located in a stand, the objective may be met with the use of ambient lighting or stand floodlighting. [(see 5.3.10)]

5.3.9.2 For a surface-level heliport, lighting for the TLOF in a FATO, shall consist of either of the following:

- (a) perimeter lights; or
- (b) arrays of Segmented Point Source Lighting (ASPSL) or luminescent panel (LP) lighting to identify the TLOF perimeter when a) is not practicable and FATO perimeter lights are available.



5.3.9.3 For an elevated heliport, shipboard heliport or helideck, lighting of the TLOF in a FATO shall consist of:

- (a) perimeter lights; and
- (b) ASPSL and/or LPs to identify the TDFC and/or floodlighting to illuminate the TLOF.

5.3.9.4 When enhanced surface texture cues are required at a TLOF ASPSL and/or LPs to identify the TDPC and/or floodlighting should be provided at a surface-level heliport intended for use at night.

Location

5.3.9.5 [TLOF perimeter lights shall be placed along the edge of the area designated for use as the TLOF or within a distance of 1.5 m from the outer edge. TLOF perimeter lights shall be uniformly spaced at intervals of not more than 3 m for elevated heliports, helidecks and shipboard heliports and not more than 5 m for surface-level heliports.]

5.3.9.6 The TLOF perimeter lights shall be installed at an elevated heliport or fixed helideck such that the pattern cannot be seen by the pilot from below the elevation of the TLOF.

5.3.9.7 The TLOF perimeter lights shall be installed on a moving helideck or shipboard heliport, such that the pattern cannot be seen by the pilot from below the elevation of the TLOF when the helideck or shipboard heliport is level.

5.3.9.8 On surface-level heliports, ASPSL or LPs, if provided to identify the TLOF, shall be placed along the marking designating the edge of the TLOF. Where the TLOF is a circle, they shall be located on straight lines circumscribing the area.

5.3.9.9 [TLOF floodlights where provided shall be arranged so as to avoid glare to pilots in flight or to personnel working on the area.]

Characteristics

5.3.9.10 The TLOF perimeter lights shall be fixed omnidirectional lights showing green.

5.3.9.11 At a surface-level heliport, ASPSL or LPs shall emit green light when used to define the perimeter of the TLOF.

5.3.9.12 The chromaticity and luminance of colours of LPs should conform to ICAO Annex 14, Volume I, Appendix 1, 3.4.

5.3.9.13 An LP shall have a minimum width of 6 cm. The panel housing shall be the same colour as the marking it defines.

5.3.9.14 For a surface level or elevated heliport the TLOF perimeter lights located in a FATO shall not exceed a height of 25 cm and shall be inset when a light extending above the surface could endanger helicopter operations.

5.3.9.15 For a helideck or shipboard heliport, the TLOF perimeter lights shall not exceed a height of 5 cm, or for a FATO/TLOF, 15 cm.

5.3.9.16 When located within the safety area of a surface level or elevated heliport, the TLOF floodlights should not exceed a height of 25 cm.



5.3.9.17 For a helideck or shipboard heliport, the TLOF floodlights shall not exceed a height of 5 cm, or for a FATO/TLOF, 15 cm.

5.3.9.18 [The ASPSL and LPs shall not extend above the surface by more than 2.5 cm.]

5.3.9.19 The light distribution of the perimeter lights should be as shown in Figure 5-12, Illustration 5.

[]

5.3.9.20 The spectral distribution of TLOF area floodlights shall be such that the surface and obstacle marking can be correctly identified.

[]

5.3.9.21 [If utilized, the heliport identification marking lighting, or cross marking lighting at a hospital, should be omnidirectional showing green.]

5.3.10 Helicopter stand floodlighting

Note: The objective of helicopter stand floodlighting is to provide illumination of the stand surface and associated markings to assist the manoeuvring and positioning of a helicopter and facilitation of essential operations around the helicopter.

Application

5.3.10.1 Floodlighting should be provided on a helicopter stand intended to be used at night.

Location

5.3.10.2 Helicopter stand floodlights should be located so as to provide adequate illumination, with a minimum of glare to the pilot of a helicopter in flight and on the ground, and to personnel on the stand. The arrangement and aiming of floodlights should be such that a helicopter stand receives light from two or more directions to minimize shadows.

Characteristics

5.3.10.3 The spectral distribution of stand floodlights shall be such that the colours used for surface and obstacle marking can be correctly identified.

5.3.10.4 Horizontal and vertical illuminance shall be sufficient to ensure that visual cues are discernible for required manoeuvring and positioning, and essential operations around the helicopter can be performed expeditiously without endangering personnel or equipment.

5.3.11 Winching area floodlighting

Note: The objective of winching area floodlighting is to provide illumination of the surface, obstacles and visual cues to assist a helicopter to be positioned over, and retained within, an area from which a passenger or equipment can be lowered or raised.

Application

5.3.11.1 Winching area floodlighting shall be provided at a winching area intended for use at night.

Location

5.3.11.2 Winching area floodlights shall be located so as to avoid glare to pilots in flight or to personnel working on the area. The arrangement and aiming of floodlights shall be such that shadows are kept to a minimum.



Characteristics

5.3.11.3 The spectral distribution of winching area floodlights shall be such that the surface and obstacle markings can be correctly identified.

5.3.11.4 The average horizontal illuminance shall be at least 10 lux, measured on the surface of the winching area.

5.3.12 Taxiway lights

Note: The specifications for taxiway centre line lights and taxiway edge lights in CAR AGA 1, paras 5.3.16 and 5.3.17, are equally applicable to taxiways intended for ground taxiing of helicopters.

5.3.13 Visual aids for denoting obstacles outside and below the obstacle limitation surface.

Note: Arrangements for an aeronautical study of objects outside the obstacle limitation surface (OLS) and for other objects are addressed in CAR AGA 1, Chapter 4.

5.3.13.1 Where an aeronautical study indicates that obstacles in areas outside and below the boundaries of the OLS, established for a heliport, constitute a hazard to helicopters, they should be marked and lit, except that the marking may be omitted when the obstacle is lighted with high-intensity obstacle lights by day.

5.3.13.2 Where an aeronautical study indicates that overhead wires or cables crossing a river, waterway, valley or highway constitute a hazard to helicopters, they should be marked, and their supporting towers marked and lit.

5.3.14 Floodlighting of obstacles

[Note: The objective of obstacle floodlighting is to highlight the shape and location of obstacles in the vicinity of the heliport, to assist a pilot flying at night to avoid all obstacles by a safe margin.]

Application

5.3.14.1 At a heliport intended for use at night, obstacles shall be floodlighted if it is not possible to display obstacle lights on them.

Location

5.3.14.2 Obstacle floodlights shall be arranged so as to illuminate the entire obstacle and as far as practicable in a manner so as not to dazzle the helicopter pilots.

Characteristics

5.3.14.3 Obstacle floodlighting shall be such as to produce a luminance of at least 10 cd/m².



This Page Intentionally Left Blank



CHAPTER 6

HELIPORT EMERGENCY RESPONSE

6.1 Heliport Emergency Planning

Note: Heliport emergency planning is the process of preparing a heliport to cope with an emergency that takes place at the heliport or in its vicinity. Examples of emergencies include crashes on or off the heliport, medical emergencies, dangerous goods occurrences, fires and natural disasters.

The purpose of heliport emergency planning is to minimize the impact of an emergency by saving lives and maintaining helicopter operations.

The heliport emergency plan sets out the procedures for coordinating the response of heliport agencies or services (air traffic services unit, firefighting services, heliport administration, medical and ambulance services, aircraft operators, security services and police) and the response of agencies in the surrounding community (fire departments, police, medical and ambulance services, hospitals, military, and harbour patrol or coast guard) that could be of assistance in responding to the emergency.

- 6.1.1 A heliport emergency plan shall be established commensurate with the helicopter operations and other activities conducted at the heliport.
- 6.1.2 The plan shall identify agencies which could be of assistance in responding to an emergency at the heliport or in its vicinity. 8
- 6.1.3 The heliport emergency plan should provide for the coordination of the actions to be taken in the event of an emergency occurring at a heliport or in its vicinity.
- 6.1.4 Where an approach/departure path at a heliport is located over water, the plan should identify which agency is responsible for coordinating rescue in the event of a helicopter ditching and indicate how to contact that agency.
- 6.1.5 The plan should include, as a minimum, the following information:
 - (a) the types of emergencies planned for;
 - (b) how to initiate the plan for each emergency specified;
 - (c) the name of agencies on and off the heliport to contact for each type of emergency with telephone numbers or other contact information;
 - (d) the role of each agency for each type of emergency;
 - (e) a list of pertinent on-heliport services available with telephone numbers or other contact information;
 - (f) copies of any written agreements with other agencies for mutual aid and the provision of emergency services; and
 - (g) a grid map of the heliport and its immediate vicinity.



- 6.1.6 All agencies identified in the plan should be consulted about their role in the plan.
- 6.1.7 The plan should be reviewed and the information in it updated at least yearly or, if deemed necessary, after an actual emergency, so as to correct any deficiency found during actual emergency.
- 6.1.8 A test of the emergency plan should be carried out at least once every three years.

6.2 Rescue and firefighting

6.2.1 Applicability

- 6.2.1.1 The following specifications shall apply to new builds or replacement of existing systems or part thereof from 01 January 2023: 6.2.2.1, 6.2.3.3, 6.2.3.4, 6.2.3.6, 6.2.3.7, 6.2.3.9, 6.2.3.10, 6.2.3.12, 6.2.3.13 and 6.2.4.2.

Note: For areas for the exclusive use of helicopters at aerodromes primarily for the use of aeroplanes, distribution of extinguishing agents, response time, rescue equipment and personnel have not been considered in this section; see CAR AGA 1, Chapter 9.

- 6.2.1.2 Rescue and firefighting equipment and services shall be provided at helidecks and at elevated heliports located above occupied structures.
- 6.2.1.3 A safety risk assessment should be performed to determine the need for rescue and firefighting equipment and services at surface level heliports and elevated heliports located above unoccupied structures.

6.2.2 Level of protection provided

- 6.2.2.1 For the application of primary media the discharge rate (in litres/minute) applied over the assumed practical critical area (in m²) shall be predicated on a requirement to bring any fire which may occur on the heliport under control within one minute, measured from activation of the system at the appropriate discharge rate.

Practical critical area calculation where primary media is applied as a solid stream

Note: This section is not applicable to helidecks regardless of how primary media is being delivered.

- 6.2.2.2 The practical critical area should be calculated by multiplying the helicopter fuselage length (m) by the helicopter fuselage width (m) plus an additional width factor (W1) of 4 m. Categorization from H0 to H3 should be determined on the basis of the fuselage dimensions in Table 6-1 below.



Table 6-1 Heliport firefighting category

Category (1)	Maximum fuselage length (2)	Maximum fuselage width (3)
H0	up to but not including 8 m	1.5 m
H1	from 8 m up to but not including 12 m	2 m
H2	from 12 m up to but not including 16 m	2.5 m
H3	from 16 m up to 20 m	3 m

Note 1: For helicopters which exceed one or both of the dimensions for a category H3 heliport, it will be necessary to recalculate the level of protection using practical critical area assumptions based on the actual fuselage length and the actual fuselage width of the helicopter plus an additional width factor (W1) of 6 m.

Note 2: The practical critical area may be considered on a helicopter type-specific basis by using the formula in 6.2.2.2. Guidance on practical critical area in relation to the heliport firefighting category is given in the Heliport Manual (Doc 9261) where a discretionary 10 per cent tolerance on fuselage dimension “upper limits” is applied.

Practical critical area calculation where primary media is applied in a dispersed pattern

6.2.2.3 For heliports, except helidecks, the practical critical area should be based on an area contained within the heliport perimeter, which always includes the TLOF, and to the extent that it is load-bearing, the FATO.

6.2.2.4 For helidecks the practical critical area should be based on the largest circle capable of being accommodated within the TLOF perimeter.

Note: This base figure is applied for the practical critical area calculation for helidecks regardless of how primary media is being delivered.

6.2.3 Extinguishing agents

Note: The discharge rate of a performance level B foam is assumed to be based on an application rate of 5.5 L/min/m², and for a performance level C foam and for water, is assumed to be based on an application rate of 3.75 L/min/m². These rates may be reduced if, through practical testing, a State demonstrates that the objectives of 6.2.2.1 can be achieved for a specific foam use at a lower discharge rate (l/min).

Surface level heliports with primary media applied as a solid stream using a portable foam application system (PFAS)

Note: Except for a limited-sized surface level heliport, the assumption is made that foam dispensing equipment will be transported to the incident or accident location on an appropriate vehicle (a PFAS).

6.2.3.1 Where an RFFS is provided at a surface level heliport, the amount of primary media and complementary agents should be in accordance with Table 6-2.



Note: The minimum discharge duration in Table 6-2 is assumed to be two minutes. However, if the availability of back-up specialist fire services is remote from the heliport, consideration may need to be given to increasing the discharge duration from two minutes to three minutes.

Table 6-2 Minimum usable amounts of extinguishing agents for surface-level heliports

Category (1)	Foam meeting performance level B		Foam meeting performance level C		Complementary agents	
	Water (L) (2)	Discharge rate foam solution/minute (L) (3)	Water (L) (4)	Discharge rate foam solution/minute (L) (5)	Dry chemical powder (kg) (6)	Gaseous media (kg) (7)
H0	500	250	330	165	23	9
H1	800	400	540	270	23	9
H2	1 200	600	800	400	45	18
H3	1 600	800	1 100	550	90	36

Elevated heliports with primary media applied as a solid stream using a fixed foam application system (FFAS)

Note: The assumption is made that primary media (foam) will be delivered through a fixed foam application system such as a fixed monitor system (FMS).

6.2.3.2 Where an RFFS is provided at an elevated heliport, the amount of foam media and complementary agents should be in accordance with Table 6-3.

Note: The minimum discharge duration in Table 6-3 is assumed to be five minutes.

Table 6-3 Minimum usable amounts of extinguishing agents for elevated heliports

Category	Foam meeting performance level B		Foam meeting performance level C		Complementary agents	
	Water (L) (2)	Discharge rate foam solution/minute (L) (3)	Water (L) (4)	Discharge rate foam solution/minute (L) (5)	Dry chemical powder (kg) (6)	Gaseous media (kg) (7)
H 0	1 250	250	825	165	23	9
H 1	2 000	400	1 350	270	45	18
H 2	3 000	600	2 000	400	45	18
H 3	4 000	800	2 750	550	90	36

Elevated heliports/ limited-sized surface level heliports with primary media applied in a dispersed pattern through a fixed foam application system (FFAS) – a solid plate heliport

6.2.3.3 The amount of water required for foam production should be predicated on the practical critical area (m²) multiplied by the appropriate application rate (L/min/m²), giving a discharge rate for foam solution (in L/min). The discharge rate should be multiplied by the discharge duration to calculate the amount of water needed for foam production.



6.2.3.4 The discharge duration should be at least three minutes.

6.2.3.5 Complementary media should be in accordance with Table 6-3, for H2 operations.

Note: For helicopters with a fuselage length greater than 16 m and/or a fuselage width greater than 2.5 m, complementary media in Table 6-3 for H3 operations may be considered.

Purpose-built elevated heliports/limited-sized surface level heliport with primary media applied in a dispersed pattern through a fixed application system (FAS) – a passive fire retarding surface with water-only DIFFS

6.2.3.6 The amount of water required should be predicated on the practical critical area (m^2) multiplied by the appropriate application rate (3.75 L/min/m^2) giving a discharge rate for water (in L/min). The discharge rate should be multiplied by the discharge duration to determine the total amount of water needed.

6.2.3.7 The discharge duration should be at least two minutes.

6.2.3.8 Complementary media should be in accordance with Table 6-3, for H2 operations.

Note: For helicopters with a fuselage length greater than 16 m and/or a fuselage width greater than 2.5 m, complementary media for H3 operations may be considered.

Purpose-built helidecks with primary media applied in a solid stream or a dispersed pattern through a fixed foam application system (FFAS) – a solid plate heliport

6.2.3.9 The amount of water required for foam media production should be predicated on the practical critical area (m^2) multiplied by the application rate (L/min/m^2) giving a discharge rate for foam solution (in L/min). The discharge rate should be multiplied by the discharge duration to calculate the amount of water needed for foam production.

6.2.3.10 The discharge duration should be at least five minutes.

6.2.3.11 Complementary media should be in accordance with Table 6-3, H0 levels for helidecks up to and including 16.0 m and to H1/H2 levels for helidecks greater than 16.0 m. Helidecks greater than 24 m should adopt H3 levels.

Purpose-built helidecks with primary media applied in a dispersed pattern through a fixed application system (FAS) – a passive fire-retarding surface with water-only DIFFS

6.2.3.12 The amount of water required should be predicated on the practical critical area (m^2) multiplied by the application rate (3.75 L/min/m^2) giving a discharge rate for water (in L/min). The discharge rate should be multiplied by the discharge duration to calculate the amount of water needed.

Note: Sea-water may be used.

6.2.3.13 The discharge duration should be at least three minutes.

6.2.3.14 Complementary media should be in accordance with Table 6-3, to H0 levels for helidecks up to and including 16.0 m and to H1/H2 levels for helidecks greater than 16.0 m. Helidecks greater than 24 m should adopt H3 levels.



6.2.4 Response time

6.2.4.1 At surface level heliports, the operational objective of the rescue and firefighting response should be to achieve response times not exceeding two minutes in optimum conditions of visibility and surface conditions.

Note: Response time is considered to be the time between the initial call to the rescue and firefighting service and the time when the first responding vehicle(s) (the service) is (are) in position to apply foam at a rate of at least 50 per cent of the discharge rate specified in Table 6-2.

6.2.4.2 At elevated heliports, limited-sized surface level heliports and helidecks, the response time for the discharge of primary media at the required application rate should be 15 seconds measured from system activation. If rescue and firefighting personnel are needed, they should be immediately available on or in the vicinity of the heliport while helicopter movements are taking place.

6.2.5 Rescue arrangements

6.2.5.1 Rescue arrangements commensurate with the overall risk of the helicopter operation should be provided at the heliport.

6.2.6 Communication and alerting system

6.2.6.1 A suitable alerting and/or communication system should be provided in accordance with the emergency response plan.

6.2.7 Personnel

6.2.7.1 Where provided, the number of rescue and firefighting personnel shall be sufficient for the required task.

6.2.7.2 Where provided, rescue and firefighting personnel shall be trained to perform their duties, and maintain their competence.

6.2.7.3 Rescue and firefighting personnel shall be provided with protective equipment.

6.2.8 Means of escape

6.2.8.1 Elevated heliports and helidecks shall be provided with a main access and at least one additional means of escape.

6.2.8.2 Access points should be located as far apart from each other as is practicable.

Note: The provision of an alternative means of escape is necessary for evacuation and for access by rescue and firefighting personnel. The size of an emergency access/egress route may require consideration of the number of passengers and of special operations like Helicopter Emergency Medical Services (HEMS) that require passengers to be carried on stretchers or trolleys.